

# Power Inductor

## Automotive Grade

### APCA Series



#### Overview

Power inductors are passive electronic components used in various circuits to store energy in a magnetic field when electrical current flows through them. They are critical in filtering, energy storage, and noise suppression in power electronic systems.

They are designed to handle higher currents and are optimized for minimal power loss and thermal efficiency.

#### Benefits

1. Automotive grade available
2. High break down voltage 1000V up
3. Operating temperature range - 40°C ~ 150°C
4. Fully automated production line

#### Applications

1. Automotive Systems for Infotainment, BCM, Dashboard, ADAS, Lamp
2. Media player, Audio class - D
3. Net working, LCD Panel/TV
4. IPC Equipment

#### Product Information

Series	L (mm)	W (mm)	T (mm)	Inductance (μH)
APCA	6.0	6.3	4.5	1 ~ 470
	7.0	7.4	4.5	
	10.3	10.0	6.5	
	12.5	12.3	8.0	

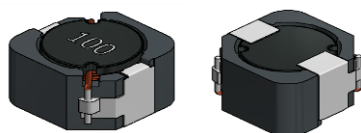

# APCA00070745 Series Specification

AEC-Q200

**1 Scope:** This specification applies to the Pb Free high current type SMD inductors

**2 Part Numbering:**

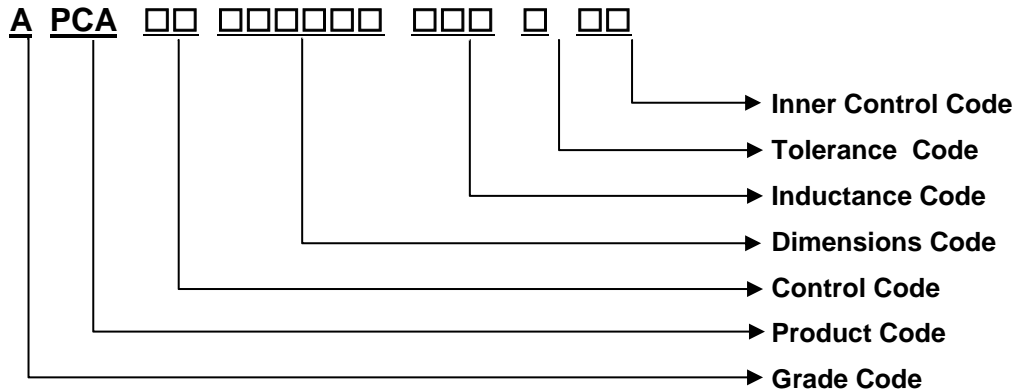

**3 Rating:**

- Operating Temperature range: -55°C ~ +150°C (Including self temp. rise)
- Storage Temperature range: -55°C ~ +150°C (For after the circuit board is mounted)
- Storage Temperature: -20°C ~ +40°C; 75% RH max. (stored in carrier tape)

**4 Standard Testing Condition**

	Unless otherwise specified	In case of doubt
Temperature	Ordinary Temperature(15 to 35°C)	20 to 30°C
Humidity	Ordinary Humidity(25 to 85% RH)	50 to 80 %RH

**5 Configuration and Dimensions:**

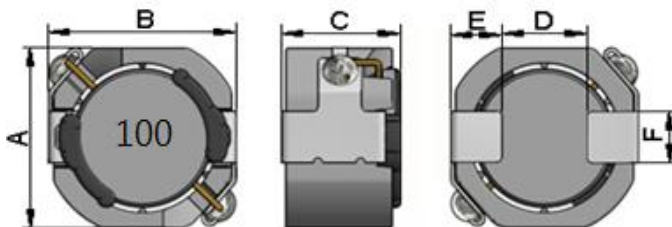

Marking Color: Black

- A: 7.00 ± 0.2 mm
- B: 7.40 ± 0.2 mm
- C: 4.50 ± 0.3 mm
- D: 3.40 Ref. mm
- E: 2.00 ± 0.1 mm
- F: 2.00 ± 0.1 mm

Net Weight (grms)

SIZE CODE	Net Weight (grms)
070745	0.79 (Typ.)

# APCA00070745 Series Specification

AEC-Q200

## 6 Electrical Characteristics:

Part No.	Inductance (uH)	Test Freq.	Resistance RDC(Ω) Max.	Rated DC Current Isat(A)	Irms(A)	Tolerance	Marking
APCA000707451R0□00	1.0	100 kHz,1.0V	0.0117	7.60	6.50	T	1R0
APCA000707451R5□00	1.5	100 kHz,1.0V	0.0130	6.20	5.40	T	1R5
APCA000707452R2□00	2.2	100 kHz,1.0V	0.0169	6.00	5.10	T	2R2
APCA000707453R3□00	3.3	100 kHz,1.0V	0.0208	4.60	4.80	T	3R3
APCA000707454R7□00	4.7	100 kHz,1.0V	0.0234	4.00	4.10	T	4R7
APCA000707456R8□00	6.8	100 kHz,1.0V	0.0264	3.00	3.90	T	6R8
APCA00070745100□00	10	100 kHz,1.0V	0.0396	2.60	3.10	M,T	100
APCA00070745150□00	15	100 kHz,1.0V	0.0660	2.00	2.60	M,T	150
APCA00070745220□00	22	100 kHz,1.0V	0.0828	1.60	2.20	M,T	220
APCA00070745330□00	33	100 kHz,1.0V	0.116	1.30	1.80	M,T	330
APCA00070745470□00	47	100 kHz,1.0V	0.156	1.10	1.70	M,T	470
APCA00070745680□00	68	100 kHz,1.0V	0.204	0.95	1.50	M,T	680
APCA00070745101□00	100	100 kHz,1.0V	0.312	0.80	1.05	M,T	101
APCA00070745151□00	150	100 kHz,1.0V	0.516	0.65	0.95	M,T	151
APCA00070745221□00	220	100 kHz,1.0V	0.660	0.54	0.75	M,T	221
APCA00070745331□00	330	100 kHz,1.0V	0.960	0.45	0.58	M,T	331
APCA00070745471□00	470	100 kHz,1.0V	1.44	0.37	0.46	M,T	471

**NOTE:** □-tolerance M=±20% / T=±30%

1. Isat : Based on inductance change ( $\Delta L/L_0$  : drop 30% Max. ) @ambient Temperature : 25°C
2. I rms : Based on temperature rise ( $\Delta T$  : 40°C Typ.)

**6.1 Construction:**

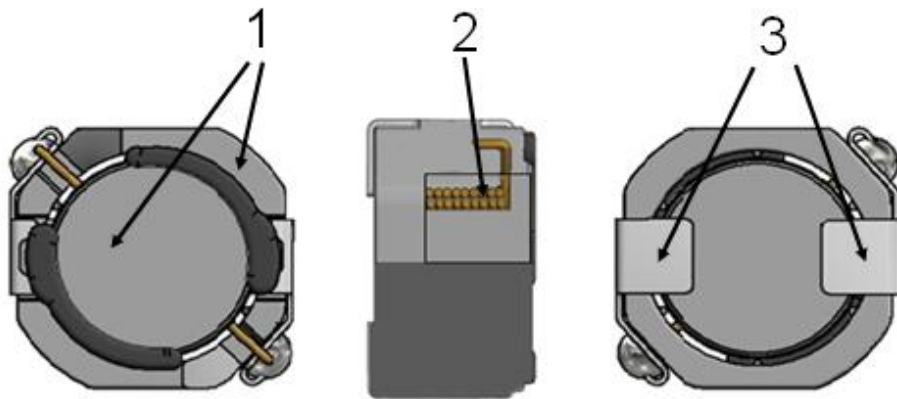

**6.2 Material List:**

NO.	ITEM	DESCRIPTION & TYPE
1	Core	Ferrite
2	Wire	Magnet Wire (P180)
3	Terminal	Terminal Copper

# APCA00070745 Series Specification

AEC-Q200

## ELECTRICAL

TEST ITEM	SPECIFICATION	TEST DETAILS
Insulation resistance	There shall be no other damage or problems.	DC 100V voltage shall be applied across this sample of top surface and the terminal. The insulation resistance shall be more than $1 \times 10^8 \Omega$ .
Dielectric withstand voltage	There shall be no other damage or problems.	AC 100V voltage shall be applied for 1 minute across the top surface and the terminal of this sample
Temperature characteristics	$\Delta L/L_{20^\circ C} \leq \pm 10\%$ 0~2000 ppm/ $^\circ C$	The test shall be performed after the sample has stabilized in an ambient temperature of -20 to +85 $^\circ C$ , and the value calculated based on the value applicable in a normal temperature and normal humidity shall be $\Delta L/L_{20^\circ C} \leq \pm 10\%$ .

## MECHANICAL

TEST ITEM	SPECIFICATION	TEST DETAILS
High Temperature Exposure (Storage)	1. $\Delta L/L_o \leq \pm 10\%$ 2. Appearance-No damage (OM)	Refer to MIL-STD-202 Method 108 1. preconditioning :reflow 3 times. 2. 1000hrs. at rated operating temperature, part can be stored for 1000 hrs. @ 150 $^\circ C$ . Unpowered. Measurement at 24 $\pm$ 4 hours after test conclusion.
Temperature Cycling	1. $\Delta L/L_o \leq \pm 10\%$ 2. Appearance-No damage (OM)	Refer to JESD22 Method JA-104 1. preconditioning :reflow 3 times. 2. 1000 cycles (-55 $^\circ C$ to +150 $^\circ C$ ). Measurement at 24 $\pm$ 4 hours after test conclusion. 30min maximum dwell time at each temperature extreme. 1 min. maximum transition time.
Biased Humidity	1. $\Delta L/L_o \leq \pm 10\%$ 2. Appearance-No damage (OM)	Refer to MIL-STD-202 Method 103 1. preconditioning :reflow 3 times. 2. 1000 hrs 85 $^\circ C$ /85%RH. Unpowered. Measurement at 24 $\pm$ 4 hours after test conclusion.
Operational Life	1. $\Delta L/L_o \leq \pm 10\%$ 2. Appearance-No damage (OM)	Refer to MIL-PRF-27 1. preconditioning :reflow 3 times. 2. 1000 hrs. @150 $^\circ C$ . Measurement 24 $\pm$ 4 hours after test conclusion.
Physical Dimensions	Product spec	Refer to JESD22-B100 Verify physical dimensions to the applicable device detail specification.

**APCA00070745 Series Specification**

AEC-Q200

**MECHANICAL**

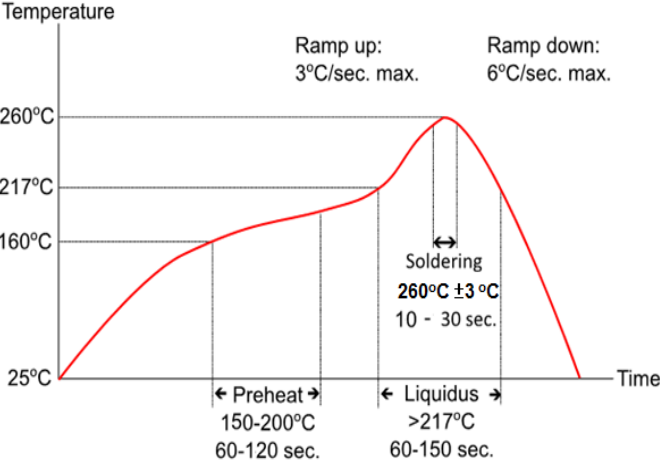
TEST ITEM	SPECIFICATION	
Resistance to Solvent	1. Marking -No constitute failure 2. No damage or degradation that has occurred due to solvent	Refer to MIL-STD-202 Method 215 Immersion 3+0.5/-0 minutes in Terpene defluxer. Brush 10 strokes (wet bristle) 2 to 3 oz. Rinse in water. Air blow dry.
Mechanical Shock	1. $\Delta L/L_0 \leq \pm 10\%$ 2. Appearance-No damage (OM)	MIL-STD-202 Method 213 Units are non-operating. Pulse shape : Half-sine waveform Impact acceleration : 100 g's Pulse duration : 6 ms Number of shocks : 18 shocks ( 3 shocks for each face)
Vibration	1. $\Delta L/L_0 \leq \pm 10\%$ 2. Appearance-No damage (OM)	MIL-STD-202 Method 204 5 g's for 20 minutes, 12 cycles each of 3 orientations. Test from 10-2000Hz.
Resistance to Soldering heat (reflow soldering)	1. $\Delta L/L_0 \leq \pm 10\%$ 2. Appearance-No damage (OM)	<p style="text-align: center;"><b>Temperature profile of reflow soldering</b></p>  <p>Refer to MIL-STD-202 Method 210                      SMD: Condition K, time above 217°C, 60s – 150s, 3Cycles</p>
Solderability	All terminations shall exhibit a continuous solder coating free from defects for a minimum of 95% of the critical area of any individual termination.	Refer to J-STD-002 For both Leaded & SMD. Electrical Test not required. Magnification 30X. Conditions: SMD: a) Method B1 @ 245°C, 5+0/-0.5 s. b) Method D @ 260°C, 30+5/-0 s.

**APCA00070745 Series Specification**

AEC-Q200

ENVIRONMENT CHARACTERISTICS

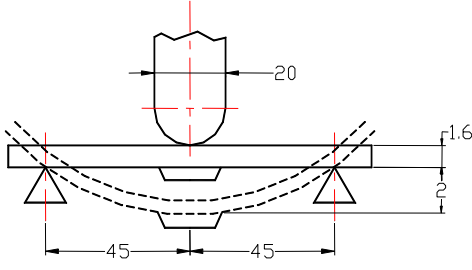
TEST ITEM	SPECIFICATION	TEST DETAILS
Board Flex	1. $\Delta L/L_0 \leq \pm 10\%$ 2. No Crack	Refer to AEC-Q200-005 Bend the board (D) X = 2mm, 60sec minimum holding time. 
Terminal Strength	1. $\Delta L/L_0 \leq \pm 10\%$ 2. Appearance-No damage (OM)	Refer to AEC-Q200-006 Apply a 1.8Kg force to the side of a device bending tested. The force shall be applied for 60+1 seconds.
Electrical Characterization	User Specification.	Parametrically test per lot and sample size requirements. Summary to show minimum, maximum, mean and standard deviation at room, minimum and maximum operating temperatures.
ESD		Refer to AEC-Q200-002 or ISO/DIS 10605 Refer to attachment third party report
Flammability	The marking and A side have no obvious broken, and the marking are clearly	Refer to UL 94 Burning stops within 10 seconds on a vertical specimen; drips of particles allowed as long as they are not inflamed.

**7 Packaging:**

**7.1 Packaging -Cover Tape**

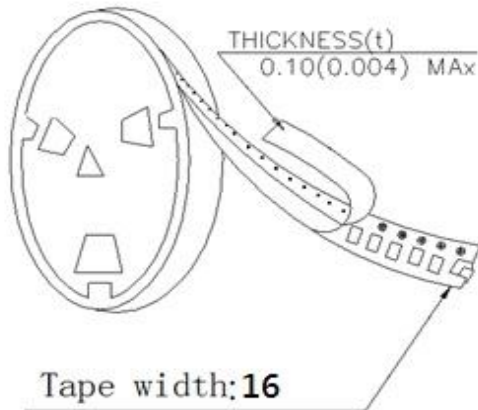

**7.2 Packaging Quantity**

TYPE	PCS/REEL
APCA00070745	1000

**7.3 Reel Dimensions**

Unit : mm

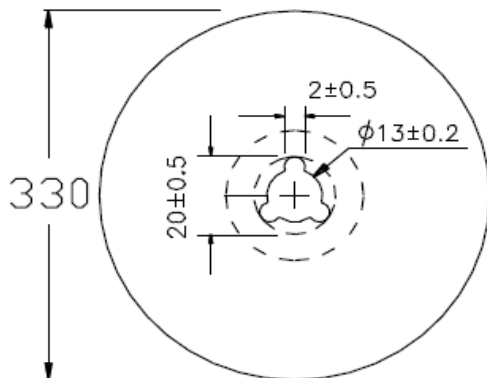

**7 Packaging:**

**7.4 Tape Dimensions in mm**

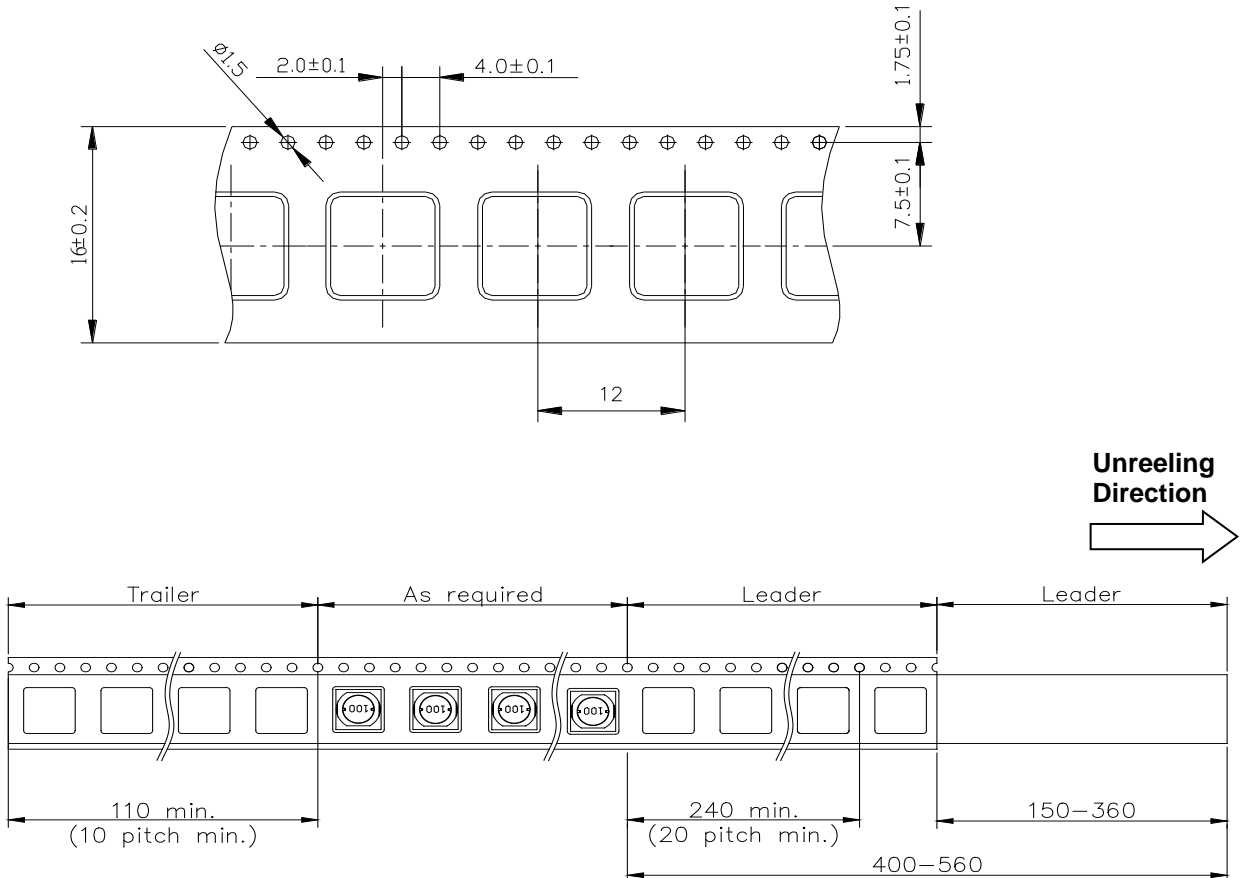

**8 Recommended Land Pattern:**

(STANDARD PATTERN) Unit : mm

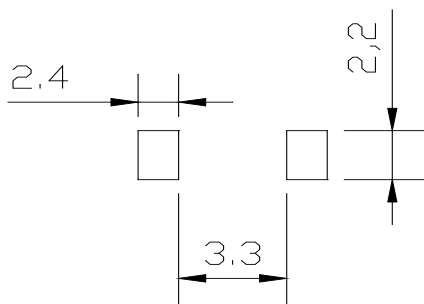

**9** Note:

1. Please make sure that your product has been evaluated and confirmed against your specifications when our product is mounted to your product.
2. Do not knock or drop.
3. All the items and parameters in this product specification have been prescribed on the premise that our product is used for the purpose, under the condition and in the environment agreed upon between you and us. You are requested not to use our product deviating from such agreement.
4. Please keep the distance between transformer/coil and other components (refer to the standard IEC 950)
5. The moisture sensitivity level (MSL) of products is classified as level 1.
6. Suggestion

On customer side this product series need to be fixed by the glue after IR reflow.

Please refer to below example photo:



**Glue**

TYPICAL ELECTRICAL CHARACTERISTICS

INDUCTANCE vs. DC CURRENT  
@100kHz/1V

TEMPERATURE vs. DC CURRENT

