

Power Inductor

BPXX Series



Overview

Power inductors are passive electronic components used in various circuits to store energy in a magnetic field when electrical current flows through them. They are critical in filtering, energy storage, and noise suppression in power electronic systems. They are designed to handle higher currents and are optimized for minimal power loss and thermal efficiency.

Benefits

1. Low Rdc and high saturation current for portable DC to DC converter line
2. High magnetic shielding construction provides high resolution for EMC protection
3. Support lead-free soldering

Applications

1. Notebook PC
2. Set top box, SSD
3. LCD TV, LCD displays
4. Portable communication device
5. DC/DC converters
6. Networking

Product Information

Series	L (mm)	W(mm)	T (mm)	Inductance (μH)
BPXX	3.0	3.0	1.0	0.3 ~ 10000
	3.0	3.0	1.2	
	3.0	3.0	1.5	
	3.0	3.0	2.0	
	4.0	4.0	1.2	
	4.0	4.0	1.8	
	4.0	4.0	2.0	
	4.0	4.0	3.0	
	5.0	5.0	1.5	
	5.0	5.0	2.0	
	5.0	5.0	3.0	
	6.0	6.0	2.0	
	6.0	6.0	2.5	
	6.0	6.0	3.0	
	6.0	6.0	3.5	



BPXX00060635 Series Specification

1 Scope: This specification applies to the Pb Free high current type SMD inductors

2 Part Numbering:

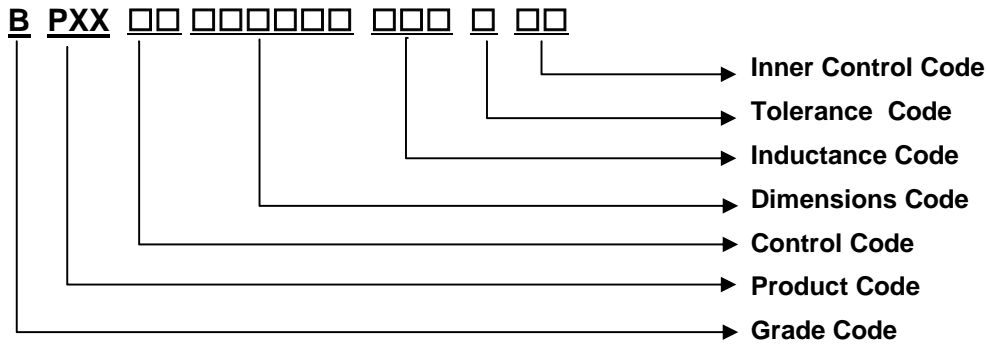

3 Rating:

Operating Temperature: $-40^{\circ}\text{C} \sim 125^{\circ}\text{C}$ (Including self - temperature rise)

Storage Temperature: (on tape & reel): -20°C to $+40^{\circ}\text{C}$; 75% RH max.

4 Standard Testing Condition:

	Unless otherwise specified	In case of doubt
Temperature	Ordinary Temperature(15 to 35°C)	20 to 30°C
Humidity	Ordinary Humidity(25 to 85% RH)	50 to 80 %RH

5 Configuration and Dimensions and Unit Weight:

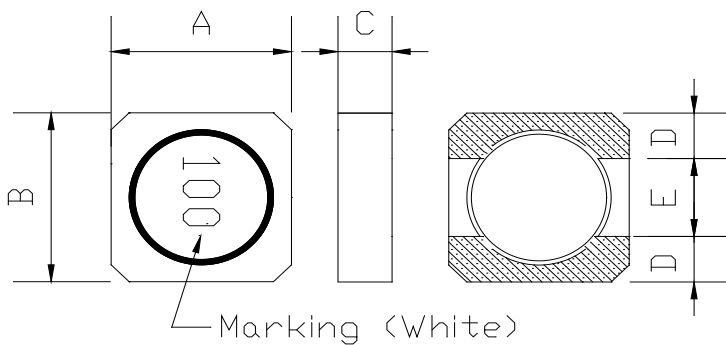

A:	6.00 ± 0.2	mm
B:	6.00 ± 0.2	mm
C:	3.50 Max.	mm
D:	2.00 Typ.	mm
E:	2.00 Typ.	mm

Net Weight (grms)

SIZE CODE	Net Weight (grms)
060635	0.469(Typ.)

BPXX00060635 Series Specification

6 Electrical Characteristics:

Part No.	Inductance L(μH)	Test Frequency	Resistance RDC(Ω) Max.	Isat1(A)	Rated DC Current			Tolerance	Marking
					Isat2(A)	Isat3(A)	Irms(A)		
BPXX00060635100□00	10	100kHz/0.1V	0.10	2.30	2.40	2.50	1.80	M,T	100
BPXX00060635220□00	22	100kHz/0.1V	0.145	1.60	1.70	1.70	2.00	M,T	220
BPXX00060635330□00	33	100kHz/0.1V	0.18	1.30	1.40	1.50	1.30	M,T	330
BPXX00060635470□00	47	100kHz/0.1V	0.245	1.10	1.20	1.20	1.20	M,T	470
BPXX00060635560□00	56	100kHz/0.1V	0.28	1.00	1.00	1.10	1.07	M,T	560
BPXX00060635680□00	68	100kHz/0.1V	0.345	0.90	0.94	0.96	1.10	M,T	680
BPXX00060635101□00	100	100kHz/0.1V	0.375	0.46	0.52	0.54	0.90	M,T	101
BPXX00060635221□00	220	100kHz/0.1V	0.72	0.31	0.36	0.37	0.64	M,T	221
BPXX00060635471□00	470	100kHz/0.1V	1.60	0.22	0.25	0.26	0.43	M,T	471
BPXX00060635681□00	680	100kHz/0.1V	2.20	0.17	0.19	0.21	0.37	M,T	681
BPXX00060635102□00	1000	100kHz/0.1V	3.20	0.14	0.17	0.18	0.30	M,T	102
BPXX00060635152□00	1500	100kHz/0.1V	4.60	0.12	0.13	0.14	0.26	M,T	152
BPXX00060635472□00	4700	10kHz/0.1V	14.5	0.070	0.077	0.084	0.150	M,T	472
BPXX00060635103□00	10000	1kHz/0.1V	30.5	0.050	0.055	0.060	0.095	M,T	103

NOTE: tolerance M=±20% , T=±30%

1. Isat1 : Based on inductance change (ΔL/Lo : drop 10% Typ.) @ambient temperature 25°C
2. Isat2 : Based on inductance change (ΔL/Lo : drop 20% Typ.) @ambient temperature 25°C
3. Isat3 : Based on inductance change (ΔL/Lo : drop 30% Typ.) @ambient temperature 25°C
4. I rms : Based on temperature rise (ΔT : 40°C Typ.)

BPXX00060635 Series Specification

6.1 Construction:

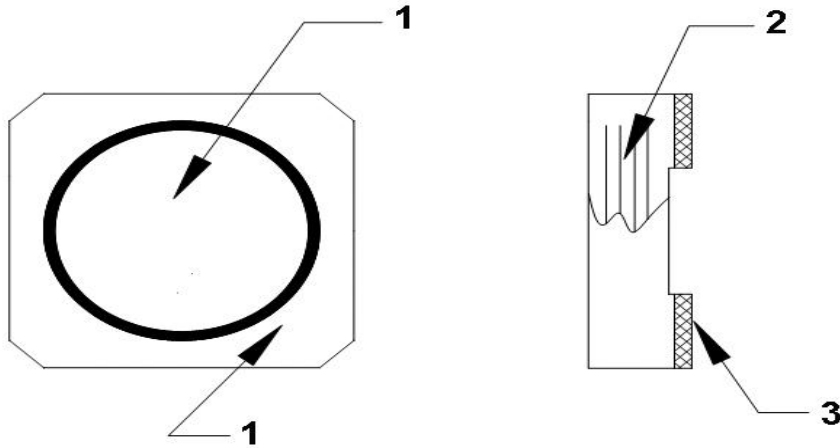

6.2 Material List:

NO.	ITEM	DESCRIPTION & TYPE
1	CORE	FERRITE
2	WIRE	MAGNET WIRE (P180)
3	TERMINAL	Ag/Cu/Ni/Sn

BPXX00060635 Series Specification

ELECTRICAL

TEST ITEM	SPECIFICATION	TEST DETAILS
Temperature characteristics	$\Delta L/L_{20^{\circ}\text{C}} \leq \pm 10\%$ 0~2000 ppm/ $^{\circ}\text{C}$	The test shall be performed after the sample has stabilized in an ambient temperature of -20 to +85 $^{\circ}\text{C}$, and the value calculated based on the value applicable in a normal temperature and normal humidity shall be $\Delta L/L_{20^{\circ}\text{C}} \leq \pm 10\%$.

MECHANICAL

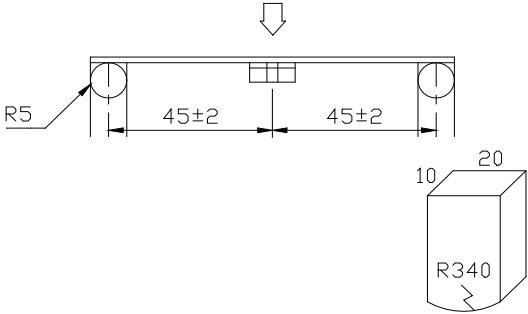
TEST ITEM	SPECIFICATION	TEST DETAILS
Substrate bending	$\Delta L/L_0 \leq \pm 10\%$ There shall be no mechanical damage or electrical damage.	The sample shall be soldered onto the printed circuit board in figure 1 and a load applied until the figure in the arrow direction is made approximately 3mm. (keep time 30 seconds) PCB dimension shall be the page 7/9 F(Pressurization)  PRESSURE ROD figure-1

BPXX00060635 Series Specification

MECHANICAL

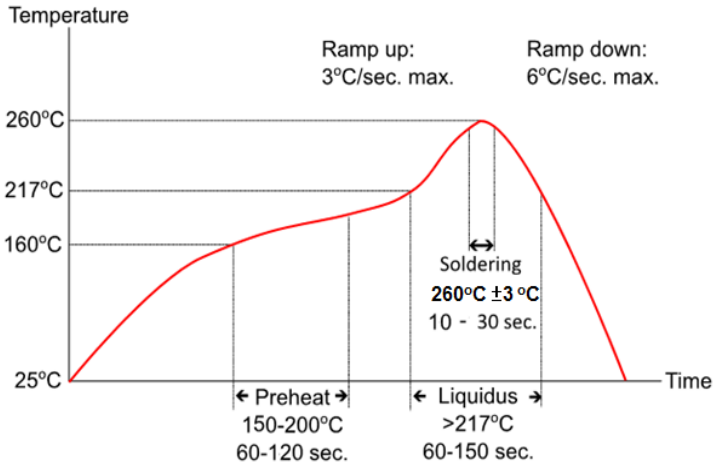
TEST ITEM	SPECIFICATION	
Vibration	$\Delta L/Lo \leq \pm 10\%$ There shall be no mechanical damage.	The sample shall be soldered onto the printed circuit board and when a vibration having an amplitude of 1.52mm and a frequency of from 10 to 55Hz/1 minute repeated should be applied to the 3 directions (X,Y,Z) for 2 hours each. (A total of 6 hours)
Solderability	New solder More than 90%	Flux (rosin, isopropyl alcohol{JIS-K-1522}) shall be coated over the whole of the sample before hard, the sample shall then be preheated for about 2 minutes in a temperature of 130~150°C and after it has been immersed to a depth 0.5mm below for 3±0.2 seconds fully in molten solder M705 with a temperature of 245±5°C. More than 90% of the electrode sections shall be covered with new solder smoothly when the sample is taken out of the solder bath.
Resistance to Soldering heat (reflow soldering)	There shall be no damage or problems.	<p style="text-align: center;">Temperature profile of reflow soldering</p>  <p>The specimen shall be passed through the reflow oven with the condition shown in the above profile for 1 time.</p> <p>The specimen shall be stored at standard atmospheric conditions for 1 hour, after which the measurement shall be made.</p>

BPXX00060635 Series Specification

ENVIRONMENT CHARACTERISTICS

TEST ITEM	SPECIFICATION																
High temperature storage	$\Delta L/Lo \leq \pm 10\%$ There shall be no mechanical damage.	The sample shall be left for 96 ± 4 hours in an atmosphere with a temperature of 125°C and a normal humidity. Upon completion of the measurement shall be made after the sample has been left in a normal temperature and normal humidity for 1 hour.															
Low temperature storage	$\Delta L/Lo \leq \pm 10\%$ There shall be no mechanical damage.	The sample shall be left for 96 ± 4 hours in an atmosphere with a temperature of $-40 \pm 3^\circ\text{C}$. Upon completion of the test, the measurement shall be made after the sample has been left in a normal temperature and normal humidity for 1 hour.															
Change of temperature	$\Delta L/Lo \leq \pm 10\%$ There shall be no other damage of problems	The sample shall be subject to 5 continuous cycles, such as shown in the table 2 below and then it shall be subjected to standard atmospheric conditions for 1 hour, after which measurement shall be made.															
table 2																	
<table border="1"> <thead> <tr> <th></th> <th>Temperature</th> <th>Duration</th> </tr> </thead> <tbody> <tr> <td>1</td> <td>$-40 \pm 3^\circ\text{C}$ (Thermostat No.1)</td> <td>30 min.</td> </tr> <tr> <td>2</td> <td>Standard atmospheric</td> <td>No.1→No.2</td> </tr> <tr> <td>3</td> <td>$125 \pm 2^\circ\text{C}$ (Thermostat No.2)</td> <td>30 min.</td> </tr> <tr> <td>4</td> <td>Standard atmospheric</td> <td>No.2→No.1</td> </tr> </tbody> </table>				Temperature	Duration	1	$-40 \pm 3^\circ\text{C}$ (Thermostat No.1)	30 min.	2	Standard atmospheric	No.1→No.2	3	$125 \pm 2^\circ\text{C}$ (Thermostat No.2)	30 min.	4	Standard atmospheric	No.2→No.1
	Temperature	Duration															
1	$-40 \pm 3^\circ\text{C}$ (Thermostat No.1)	30 min.															
2	Standard atmospheric	No.1→No.2															
3	$125 \pm 2^\circ\text{C}$ (Thermostat No.2)	30 min.															
4	Standard atmospheric	No.2→No.1															
Moisture storage	$\Delta L/Lo \leq \pm 10\%$ There shall be no mechanical damage.	The sample shall be left for 96 ± 4 hours in a temperature of $40 \pm 2^\circ\text{C}$ and a humidity(RH) of 90~95%. Upon completion of the test, the measurement shall be made after the sample has been left in a normal temperature and normal humidity more than 1 hour.															

Test conditions :

The sample shall be reflow soldered onto the printed circuit board in every test.

BPXX00060635 Series Specification

7 Packaging:

7.1 Packaging -Cover Tape

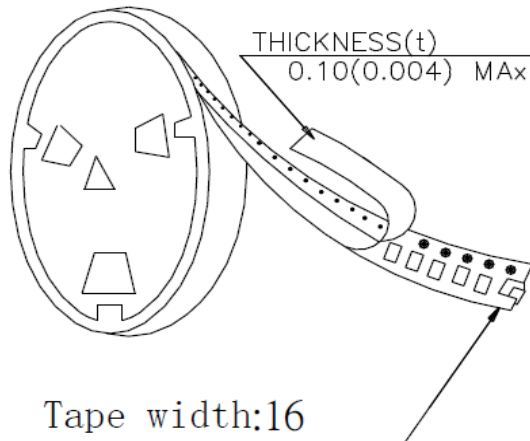

7.2 Packaging Quantity

TYPE	PCS/REEL
BPXX00060635	1500

7.3 Reel Dimensions

Unit : mm

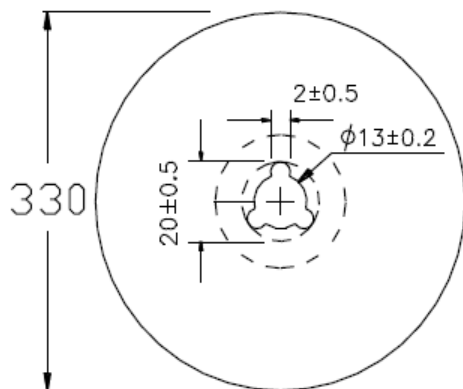

BPXX00060635 Series Specification

7 Packaging:

7.4 Tape Dimensions in mm

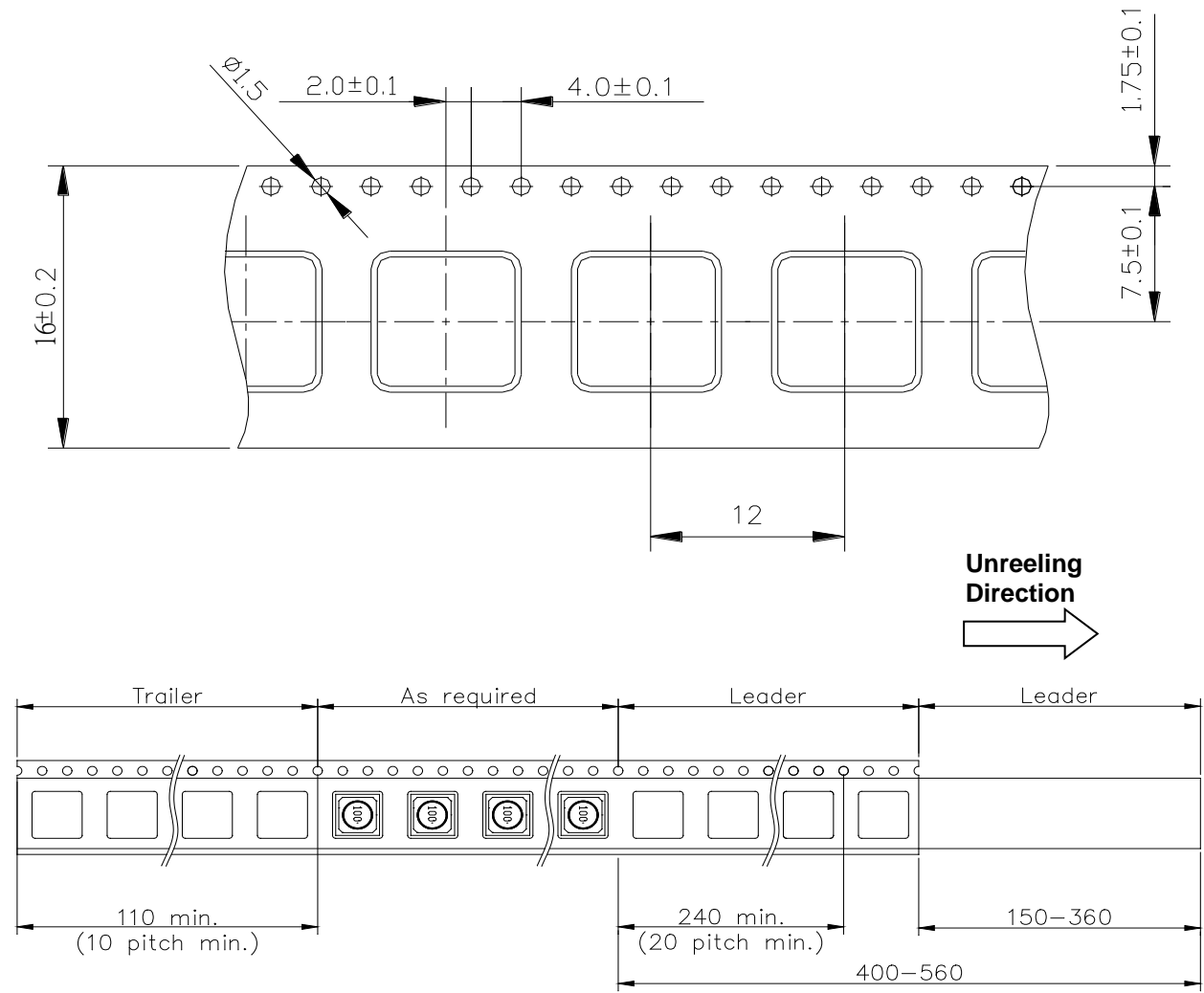

8 Recommended Land Pattern:

(STANDARD PATTERN) Unit : mm

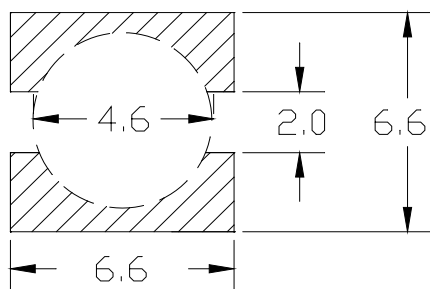

BPXX00060635 Series Specification

9 Note:

1. Please make sure that your product has been evaluated and confirmed against your specifications when our product is mounted to your product.
2. Do not knock or drop.
3. All the items and parameters in this product specification have been prescribed on the premise that our product is used for the purpose, under the condition and in the environment agreed upon between you and us. You are requested not to use our product deviating from such agreement.
4. Please keep the distance between transformer/coil and other components (refer to the standard IEC 950)
5. The moisture sensitivity level (MSL) of products is classified as level 1.
6. Void Appearance Tolerance Limit

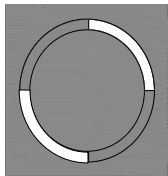

6-1. The length of the hole in the epoxy of the sealed glue position should be less than $1/2$ of the DR core 's circumference, otherwise, it is NG.

6-2. The total length of the amount of hole in the epoxy should be less than $1/2$ of the DR core 's circumference, otherwise, it is NG.

BPXX00060635 Series Specification

TYPICAL ELECTRICAL CHARACTERISTICS

INDUCTANCE vs. DC CURRENT
@100KHz/0.1V

TEMPERATURE vs. DC CURRENT

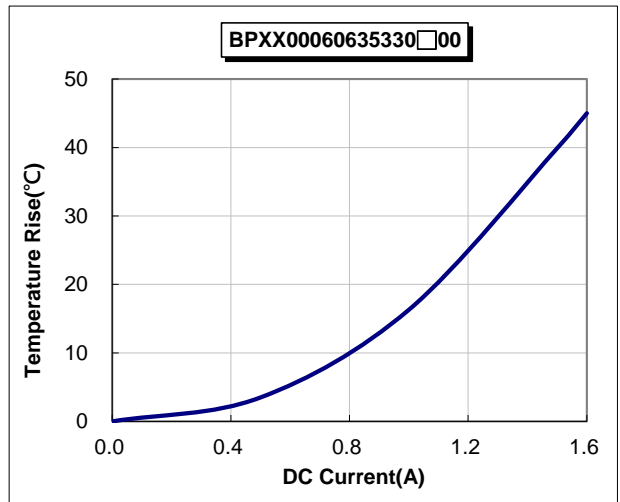
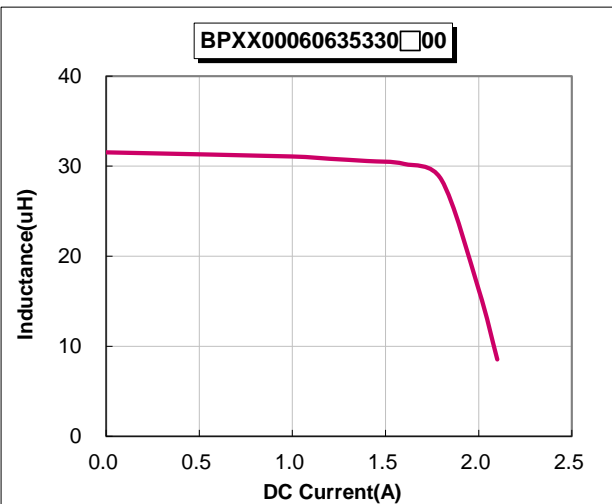
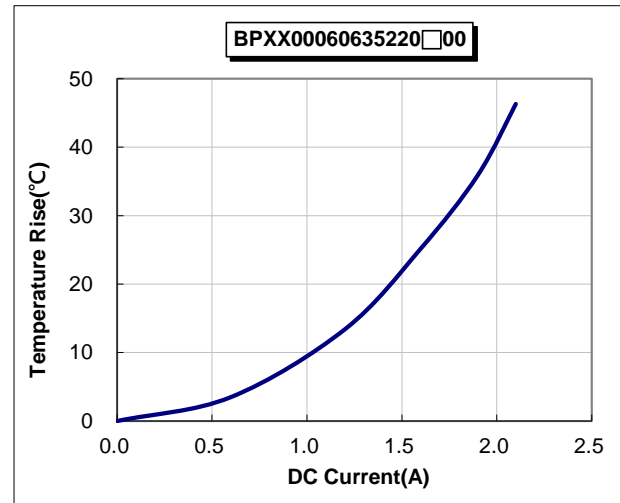
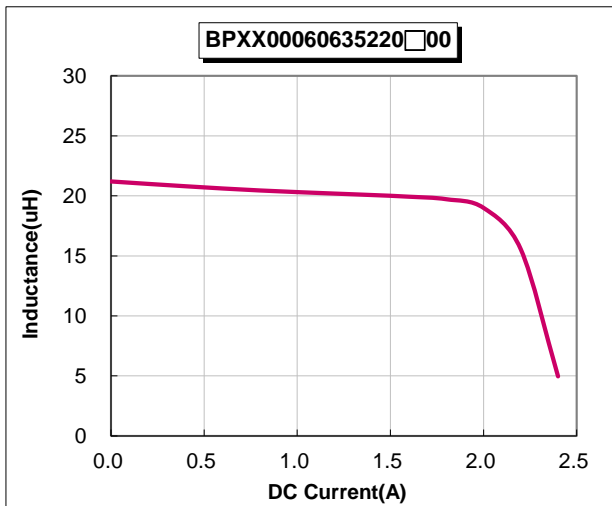
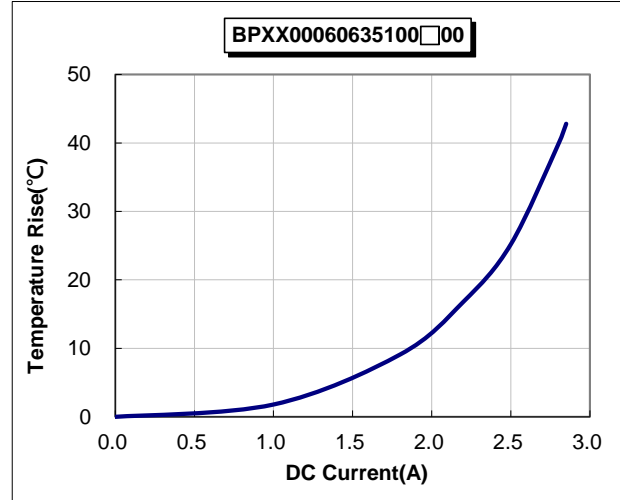
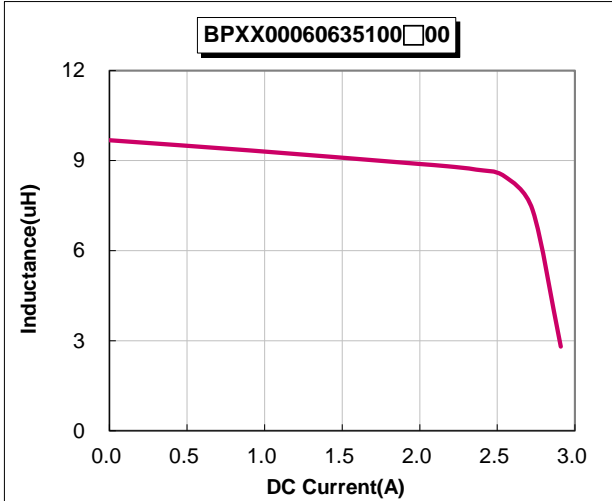

BPXX00060635 Series Specification

TYPICAL ELECTRICAL CHARACTERISTICS

INDUCTANCE vs. DC CURRENT
@100KHz/0.1V

TEMPERATURE vs. DC CURRENT

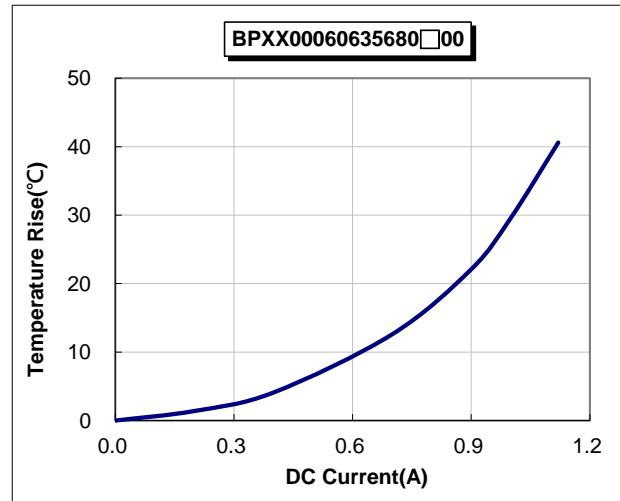
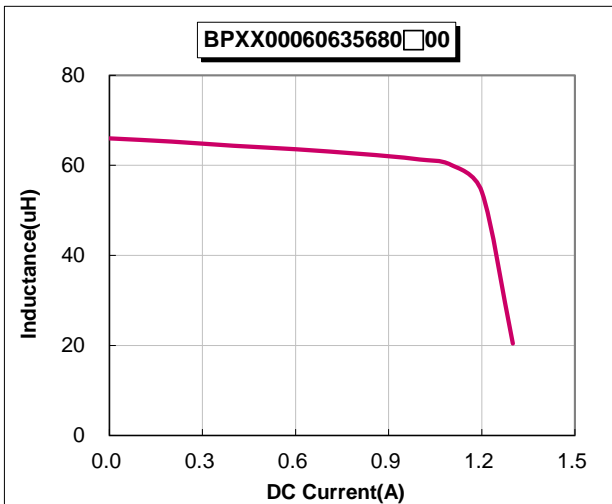
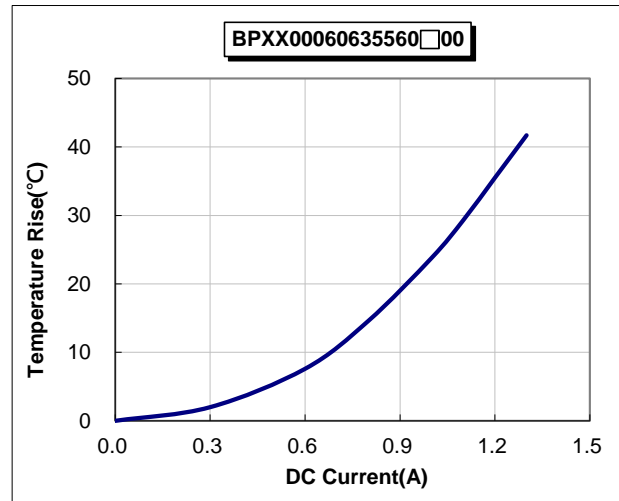
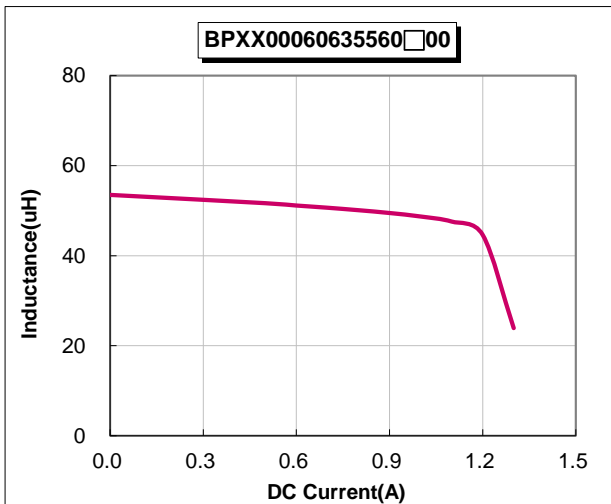
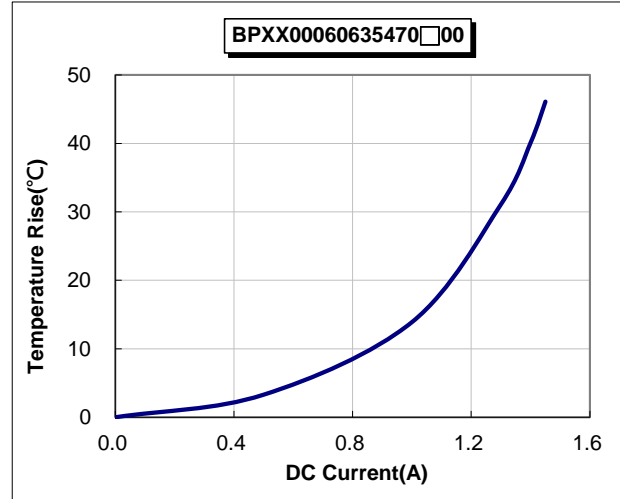
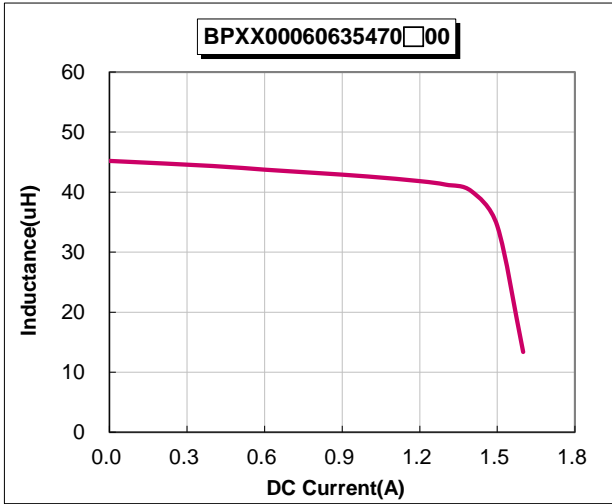

BPXX00060635 Series Specification

TYPICAL ELECTRICAL CHARACTERISTICS

INDUCTANCE vs. DC CURRENT
@100KHz/0.1V

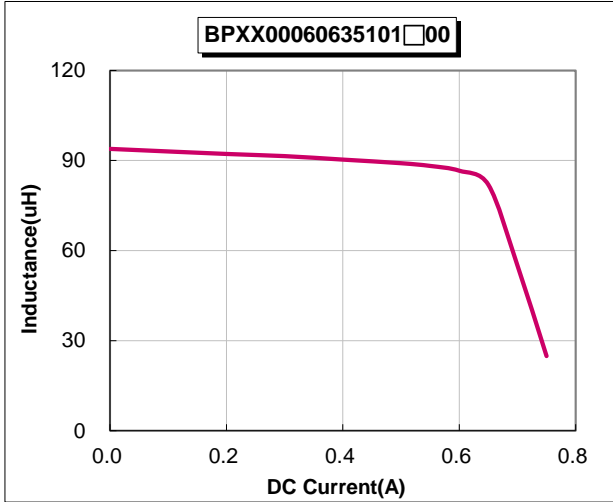

TEMPERATURE vs. DC CURRENT

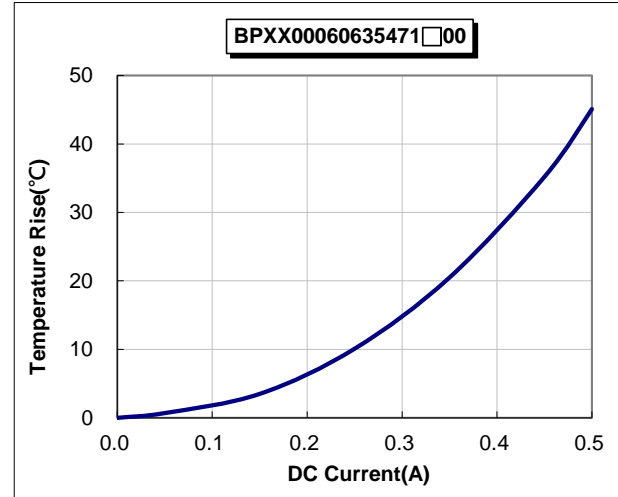
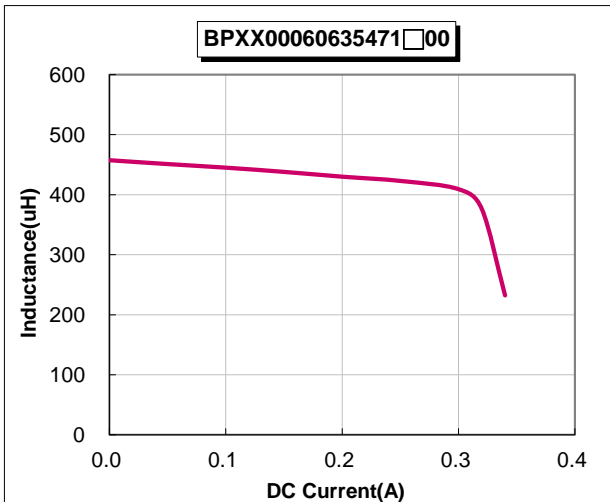
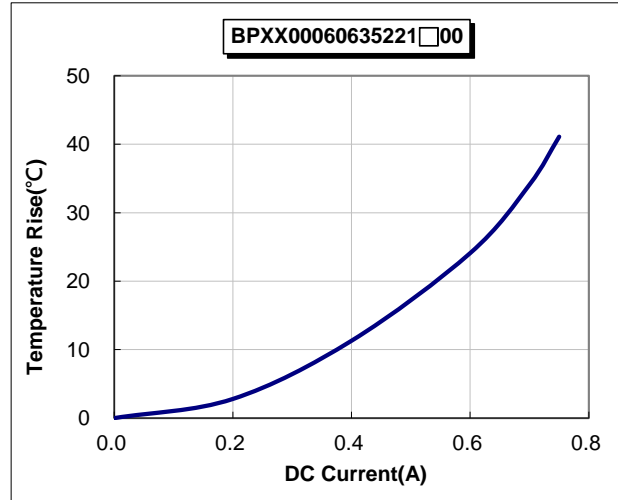
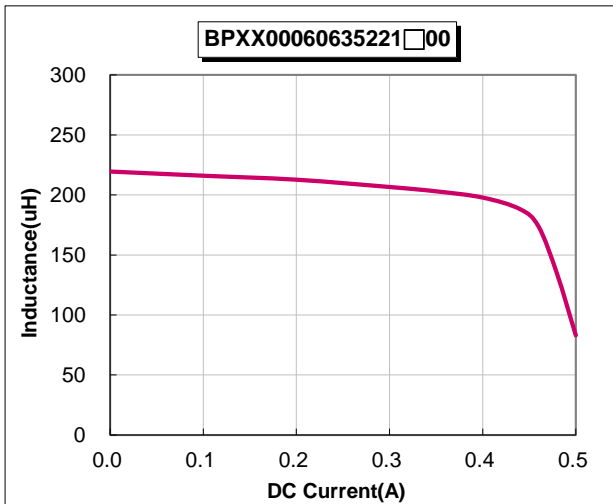
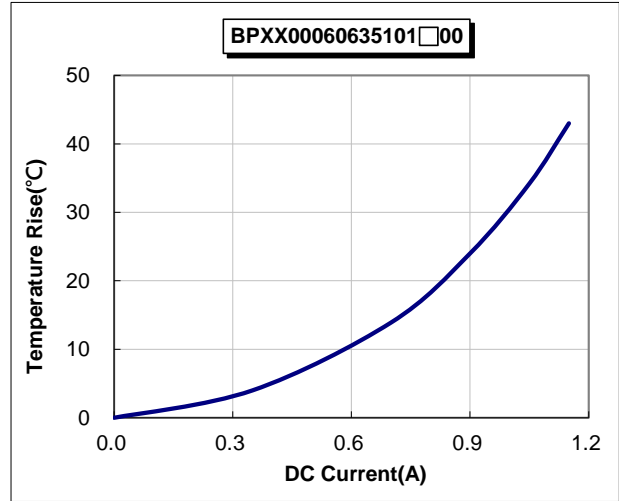

BPXX00060635 Series Specification

TYPICAL ELECTRICAL CHARACTERISTICS

INDUCTANCE vs. DC CURRENT
@100KHz/0.1V

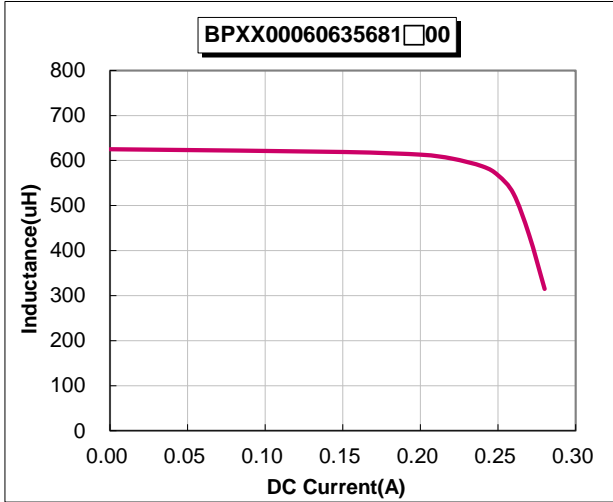

TEMPERATURE vs. DC CURRENT

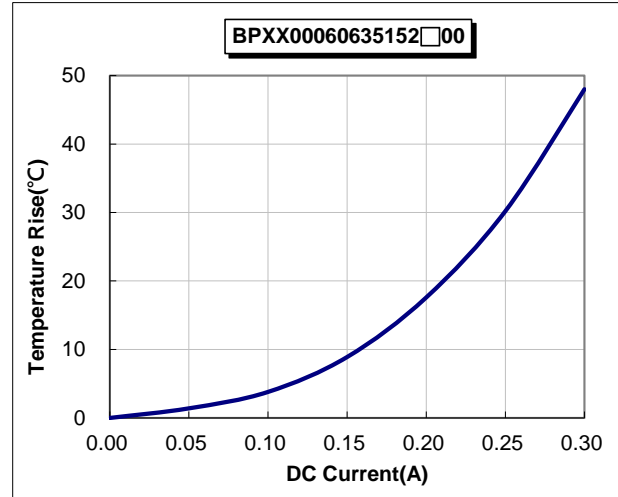
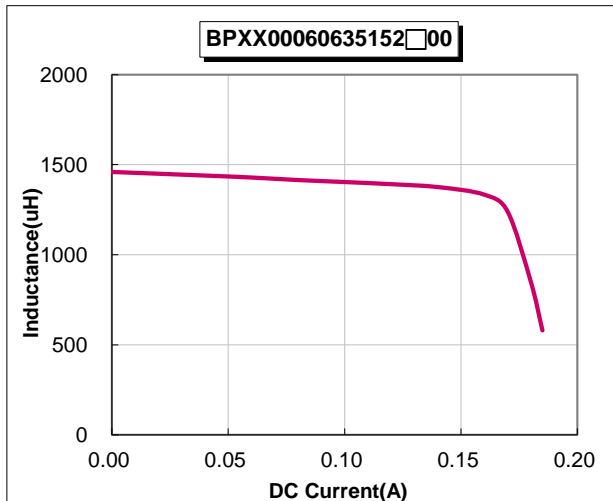
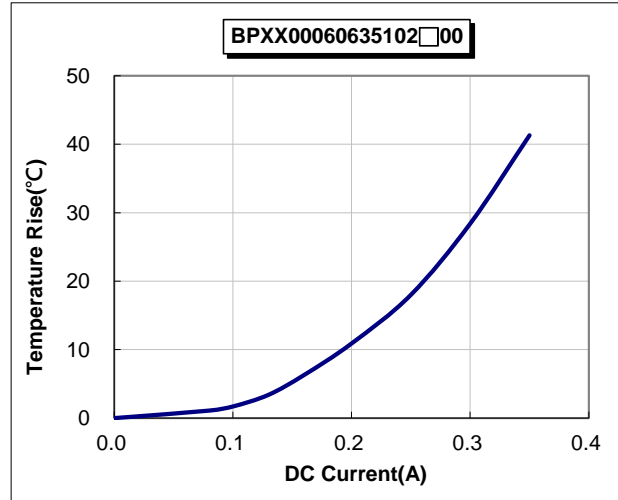
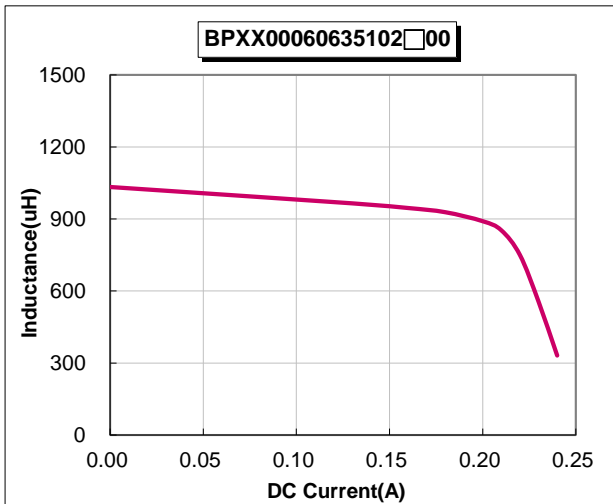
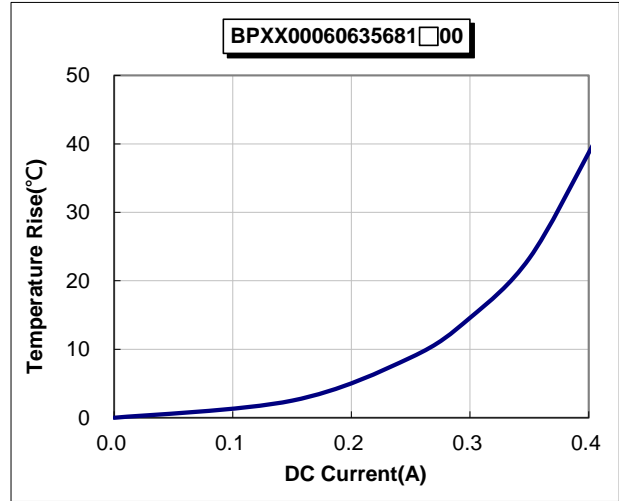

BPXX00060635 Series Specification

TYPICAL ELECTRICAL CHARACTERISTICS

INDUCTANCE vs. DC CURRENT
@10KHz/0.1V

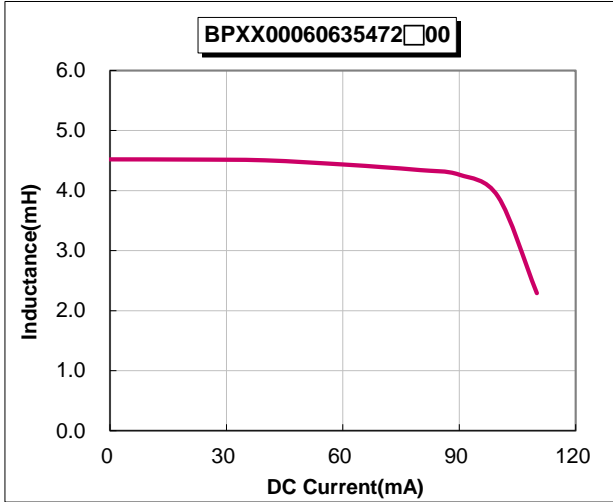

TEMPERATURE vs. DC CURRENT

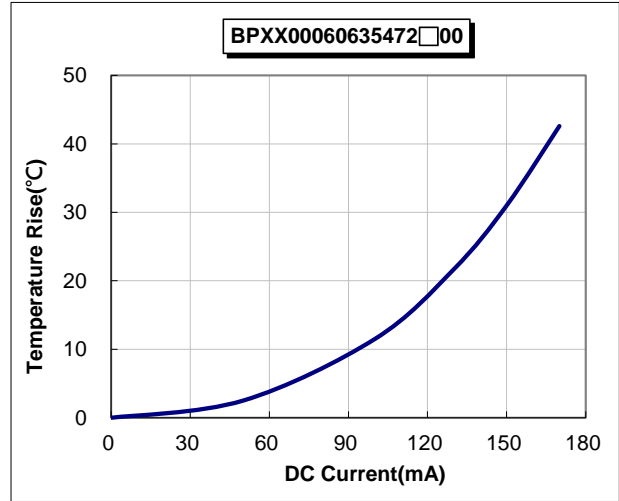

INDUCTANCE vs. DC CURRENT
@1KHz/0.1V

