

RF Inductor

BWNC Series



Overview

Wire-wound RF inductors are electronic components designed to store energy in a magnetic field when electrical current passes through them. They are constructed by winding a conductive wire (usually copper or gold-plated) around a core material such as air, ceramic, or ferrite.

This configuration allows them to provide high inductance values with minimal power loss, especially at high frequencies.

Benefits

1. Low RDC and carry large current
2. Terminals are highly resistant to pull forces
3. Highly resistant to mechanical shocks and pressure
4. Superior IDC for DC/DC converter

Applications

1. DC/DC converter such as DSC
2. LCD TV
3. Game console
4. Portable VCRs

Product Information

Series	Size Code (JIS/EIA)	Inductance (nH)
BWNC	3838/1515	1 ~ 1000



BWNC00372926 Series Specification

1 Scope: This specification applies to Wire Wound Ferrite Chip Inductors

2 Part numbering:

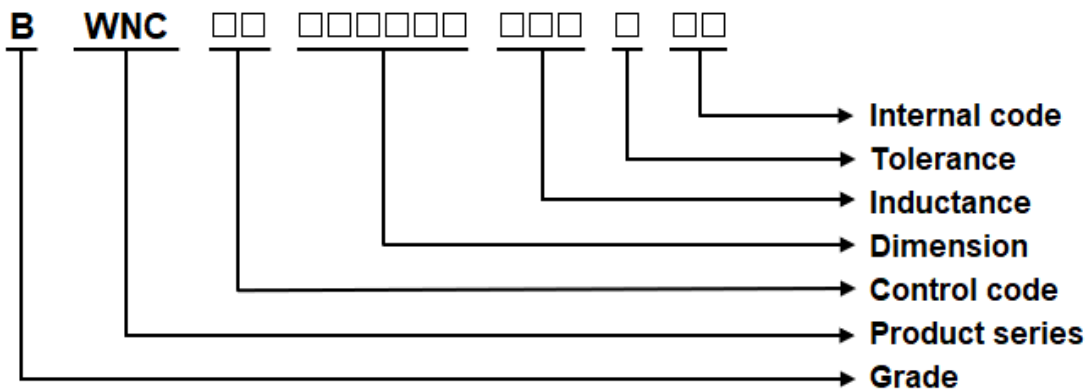

3 Rating:

Operating Temperature: -40°C ~ 105°C
(Including self - temperature rise)

Storage Temperature: -40°C ~ 105°C
(The storage temperature range is for after the assembly)

4 Marking:

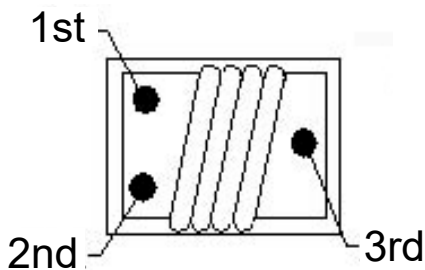

Ex Marking: 1st → BRN
2nd → BLK
3rd → RED

5 Standard Testing Condition

	Unless otherwise specified	In case of doubt
Temperature	Ordinary Temperature(15 to 35°C)	20 to 30°C
Humidity	Ordinary Humidity(25 to 85% RH)	50 to 80 %RH

BWNC00372926 Series Specification

6 Configuration and Dimensions and Unit Weight:

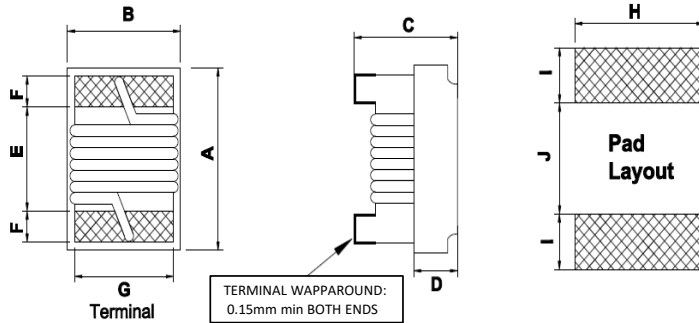

Dimensions in mm

TYPE	372926
A	3.70Max.
B	2.90Max.
C	2.60Max.
D	0.70
E	2.00
F	0.60
G	2.40
H	2.70
I	1.00
J	2.00

Size Code	Net weight(grams)
372926	0.07

7 Electrical Characteristics:

Part No.	Inductance (uH)	L,Q Test Freq. (MHz)	Q Min.	SRF (MHz)Typ.	RDC (Ω)±30%	IDC (mA)	Tolerance (±%)	Color Code		
								1st	2nd	3rd
BWNC00372926R15□00	0.15	25.2	40	700	0.035	1800	5,10	BRN	GRN	BRN
BWNC00372926R22□00	0.22	25.2	40	700	0.05	1800	5,10	RED	RED	BRN
BWNC00372926R27□00	0.27	25.2	40	700	0.05	1800	5,10	RED	VIO	BRN
BWNC00372926R33□00	0.33	25.2	40	650	0.07	1700	5,10	ORN	ORN	BRN
BWNC00372926R39□00	0.39	25.2	40	600	0.06	1800	5,10	ORN	WHT	BRN
BWNC00372926R47□00	0.47	25.2	40	450	0.07	1800	5,10	YEL	VIO	BRN
BWNC00372926R56□00	0.56	25.2	35	400	0.07	1700	5,10	GRN	BLU	BRN
BWNC00372926R68□00	0.68	25.2	35	350	0.075	1650	5,10	BLU	GRY	BRN
BWNC00372926R82□00	0.82	25.2	35	300	0.08	1600	5,10	GRY	RED	BRN
BWNC00372926R91□00	0.91	25.2	30	250	0.08	1500	5,10	WHT	BRN	BRN
BWNC003729261R0□00	1	7.96	20	100	0.08	1500	5,10	BRN	BLK	RED
BWNC003729261R2□00	1.2	7.96	20	90	0.12	1400	5,10	BRN	RED	RED
BWNC003729261R5□00	1.5	7.96	20	80	0.13	1125	5,10	BRN	GRN	RED
BWNC003729261R8□00	1.8	7.96	20	70	0.13	970	5,10	BRN	GRY	RED
BWNC003729262R2□00	2.2	7.96	20	68	0.13	970	5,10	RED	RED	RED
BWNC003729262R7□00	2.7	7.96	20	62	0.15	900	5,10	RED	VIO	RED
BWNC003729263R3□00	3.3	7.96	20	54	0.16	837	5,10	ORN	ORN	RED
BWNC003729263R9□00	3.9	7.96	20	48	0.24	750	5,10	ORN	WHT	RED
BWNC003729264R7□00	4.7	7.96	20	43	0.23	675	5,10	YEL	VIO	RED
BWNC003729265R6□00	5.6	7.96	20	36	0.26	620	5,10	GRN	BLU	RED
BWNC003729266R8□00	6.8	7.96	20	33	0.27	600	5,10	BLU	GRY	RED
BWNC003729268R2□00	8.2	7.96	20	30	0.32	580	5,10	GRY	RED	RED

NOTE: □-tolerance J=±5% / K=±10% M=±20%

1. Operating temperature range - 40 ~ 105

2. IDC: Applied the current to coils, the inductance shall be less than 10% initial value.

3. Absolute maximum voltage 50VDC

BWNC00372926 Series Specification

Part No.	Inductance (uH)	L,Q Test Freq. (MHz)	Q Min.	SRF (MHz)Typ.	RDC (Ω)±30%	IDC (mA)	Tolerance (±%)	Color Code		
								1st	2nd	3rd
BWNC00372926100□00	10	2.52	15	28	0.36	520	5,10	BRN	BLK	ORN
BWNC00372926120□00	12	2.52	15	25	0.5	500	5,10	BRN	RED	ORN
BWNC00372926150□00	15	2.52	15	19	0.56	480	5,10	BRN	GRN	ORN
BWNC00372926180□00	18	2.52	15	17	0.67	330	5,10	BRN	GRY	ORN
BWNC00372926220□00	22	2.52	15	16	0.77	310	5,10	RED	RED	ORN
BWNC00372926270□00	27	2.52	15	13	1	280	5,10	RED	VIO	ORN
BWNC00372926330□00	33	2.52	15	12	1.1	270	5,10	ORN	ORN	ORN
BWNC00372926390□00	39	2.52	15	11	1.4	220	5,10	ORN	WHT	ORN
BWNC00372926470□00	47	2.52	15	10	1.64	210	5,10	YEL	VIO	ORN
BWNC00372926560□00	56	2.52	15	9	2.49	189	5,10	GRN	BLU	ORN
BWNC00372926680□00	68	2.52	15	9	2.8	189	5,10	BLU	GRY	ORN
BWNC00372926820□00	82	2.52	15	6	3	145	5,10	GRY	RED	ORN
BWNC00372926101□00	100	0.796	15	6	3.7	145	5,10	BRN	BLK	YEL
BWNC00372926151□00	150	0.796	15	5	6.1	120	5,10	BRN	GRN	YEL
BWNC00372926181□00	180	0.796	15	4	8	105	5,10	BRN	GRY	YEL
BWNC00372926221□00	220	0.796	15	4	8.4	100	5,10	RED	RED	YEL
BWNC00372926331□00	330	0.796	15	3.5	12.3	80	5,10	ORN	ORN	YEL
BWNC00372926391□00	390	0.796	15	2.8	17.6	75	5,10	ORN	WHT	YEL
BWNC00372926471□00	470	0.796	15	2.8	22	75	5,10	YEL	VIO	YEL
BWNC00372926561□00	560	0.796	15	2.5	23	65	5,10	GRN	BLU	YEL
BWNC00372926681□00	680	0.796	15	2	28	65	5,10	BLU	GRY	YEL

NOTE: □-tolerance J=±5% / K=±10% M=±20%

1.Operating temperature range - 40°C ~ 105°C

2.IDC:Applied the current to coils, the inductance shall be less than 10% initial value.

3.Absolute maximum voltage 50VDC

BWNC00372926 Series Specification

8 BWNC00372926 Series

8.1 Construction:

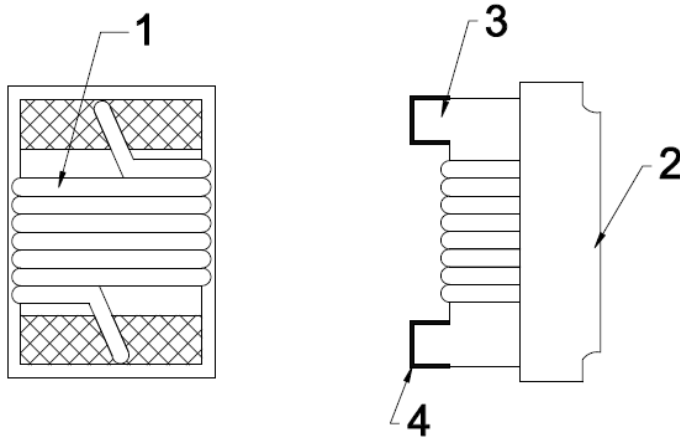

8.2 Material List:

NO	Part	Material
1	Wire	Grade 180
2	Epoxy	UV Glue
3	Core	Ferrite
4	Terminal	Ag/Cu/Ni/Sn

BWNC00372926 Series Specification

9 Reliability Of Ferrite Wire Wound Chip Inductor/FERRITE SERIES

1-1.Environmental Performance

No	Item	Specification	Test Method		
1-1-1	Temperature Cycle	Appearance: No Damage Inductance: within $\pm 10\%$ of initial value Q change: within $\pm 30\%$ of initial value	One cycle:		
			Step	Temperature ($^{\circ}\text{C}$)	Time (min)
			1	-40 \pm 3	30
			2	25 \pm 2	3
			3	105 \pm 3	30
4	25 \pm 2	3			
			Total: 5 cycles		
1-1-2	High Temperature Resistance		Measured After Exposure in The Room Condition For 1hrs Temperature: 105 \pm 3 $^{\circ}\text{C}$ Time: 1000Hrs		
1-1-3	Low Temperature Resistance		Measured After Exposure In The Room Condition For 1Hrs Temperature: -40 \pm 3 $^{\circ}\text{C}$ Time: 1000Hrs		
1-1-4	Humidity Load Life	There should be no evidence of short or open circle	Measured After Exposure In The Room Condition For 1Hrs Temperature: 40 \pm 2 $^{\circ}\text{C}$ Relative Humidity: 90~95% Load: Allowed DC Current Time: 96Hrs		

1-2.Mechanical Performance

No	Item	Specification	Test Method
1-2-1	Resistance TO Soldering Heat	Appearance: No Damage	1. The device should be reflow soldered on PCB (peak 260 $^{\circ}\text{C}$ \pm 5 $^{\circ}\text{C}$ for 10 seconds) 2. Solder Composition: Sn/Ag3.0/Cu0.5 3. Test time: 6 minutes
1-2-2	Solder ability	The electrodes shall be at least 95% covered with new solder coating	1. Pre-Heating: 150 $^{\circ}\text{C}$, 1min. 2. Solder Composition: Sn/Ag3.0/Cu0.5 3. Solder Temperature: 245 \pm 5 $^{\circ}\text{C}$. 4. Immersion Time: 4 \pm 1 sec.
1-2-3	Component Adhesion (Push Test)	2 Lbs. For 2520 Size 4 Lbs. For 3225 Size	The device should be reflow soldered (245 \pm 5 $^{\circ}\text{C}$ For 10 seconds) to a tinned copper substrate. A force gauge should be applied to the side of the component. The device must withstand a minimum force of 1or2or4 pounds without a failure of the termination attached to component

BWNC00372926 Series Specification

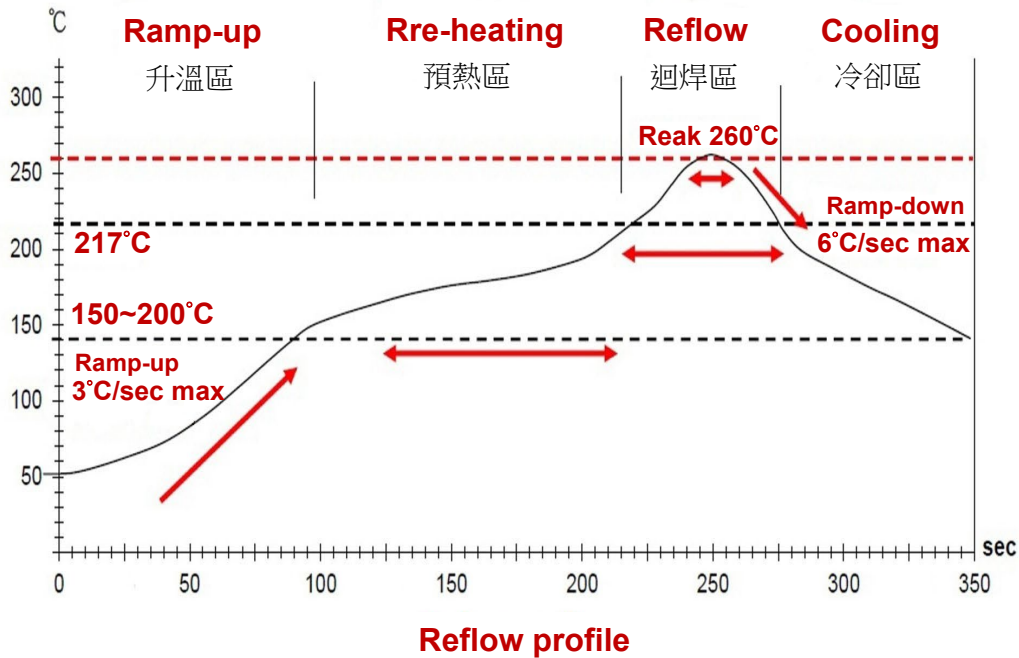

Lead-Free(LF)標準溫度分析範圍

Refer to J-STD-020C

管制項目 Item.	升溫區 Ramp-up	預熱區 Pre-heating	迴焊區 Reflow	Peak Temp	冷卻區 Cooling
溫度範圍 Temp.scope	R.T~150°C	150°C~200°C	Above 217°C	260±5°C	Peak Temp.~150°C
標準時間 Time spec.	—	60~180 sec	60~150 sec	5~10 sec	—
實際時間 Time result	—	75~100 sec	90~120 sec	10sec	—

NOTE:

- 1.Re-flow possible times : within 3 times
- 2.Nitrogen adopted is recommended while in re-flow
- 3.Products can only be soldered with reflow

BWNC00372926 Series Specification

10 Packaging:

10.1 Packaging -Cover Tape

The force for tearing off cover tape is 10 to 100 grams in the arrow direction.

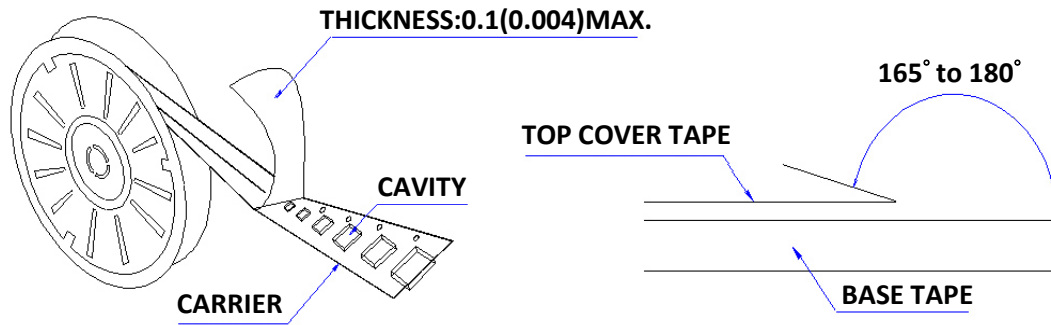

10.2 Packaging Quantity

TYPE	PCS/REEL
372926	2000

10.3 Reel Dimensions

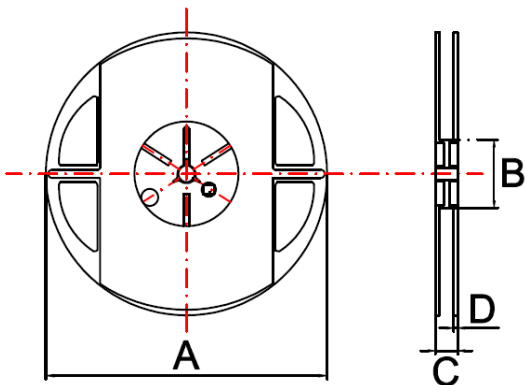

Dimensions in mm

TYPE	A	B	C	D
372926	178	60	12	1.5

BWNC00372926 Series Specification

10 Packaging:

10.4 Tape Dimensions in mm

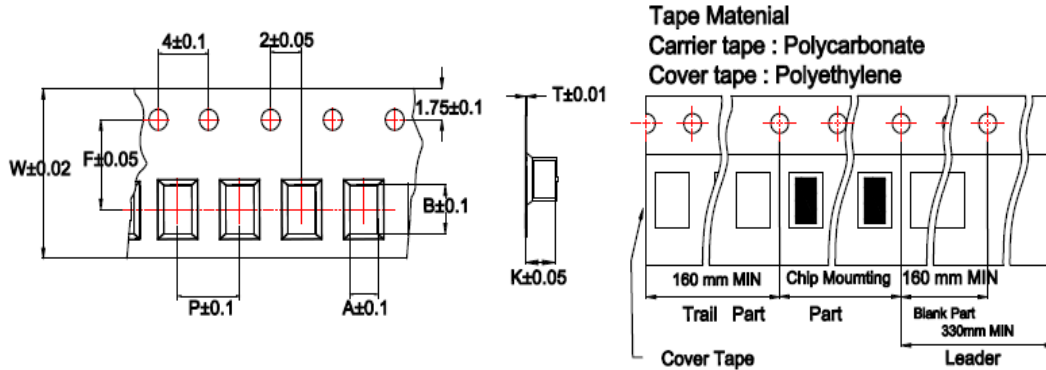

TYPE	A	B	T	W	P	F	K
372926	2.85	3.58	0.25	12	4	3.5	2.53

11 Recommended Land Pattern:

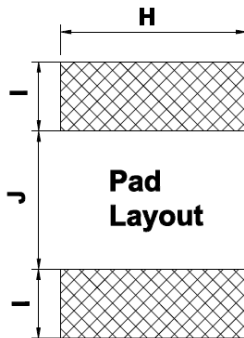

Dimensions in mm

TYPE	H(In/mm)	I(In/mm)	J(In/mm)
372926	0.106/2.7	0.039/1.0	0.079/2.0

12 Note:

- Please make sure that your product has been evaluated and confirmed against your specifications when our product is mounted to your product.
- Do not knock nor drop.
- All the items and parameters in this product specification have been prescribed on the premise that our product is used for the purpose, under the condition and in the environment agreed upon between you and us. You are requested not to use our product deviating from such agreement.
- The storage period is less than 12 months. Be sure to follow the storage conditions (Temperature: 5 to 40°C, Humidity: 10 to 75% RH or less).
If the storage period elapses, the soldering of the terminal electrodes may deteriorate.
- Do not use or store in locations where there are conditions such as gas corrosion (salt, acid, alkali, etc.).
- The moisture sensitivity level (MSL) of products is classified as level 1

BWNC00372926 Series Specification

13 Graph:

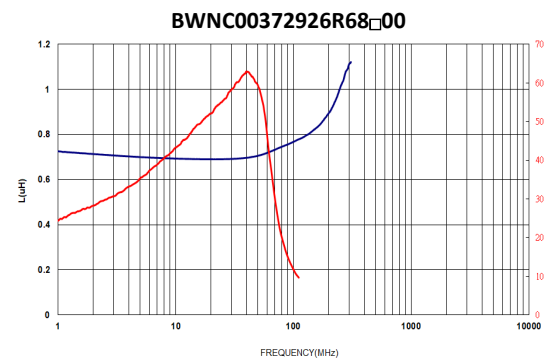
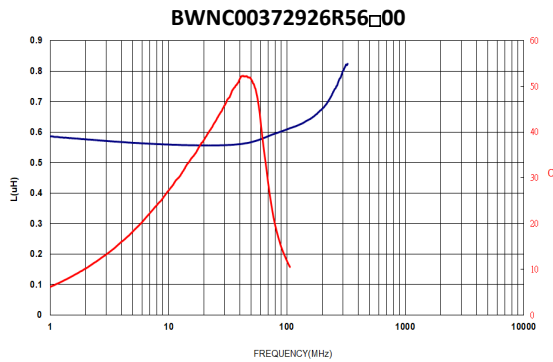
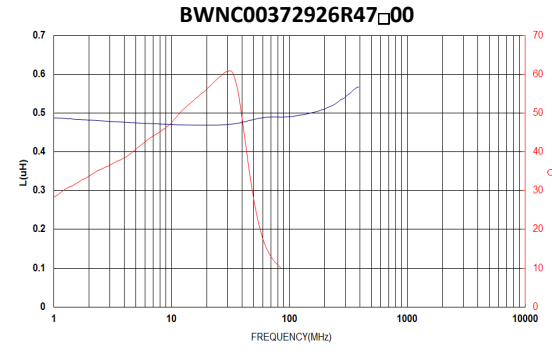
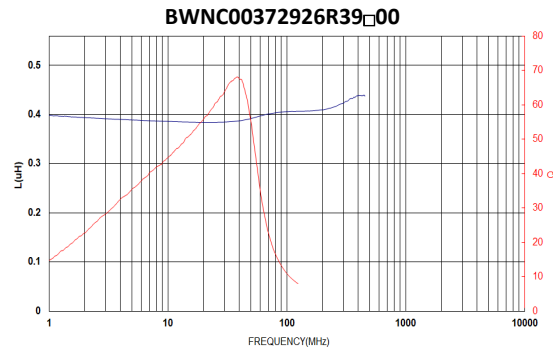
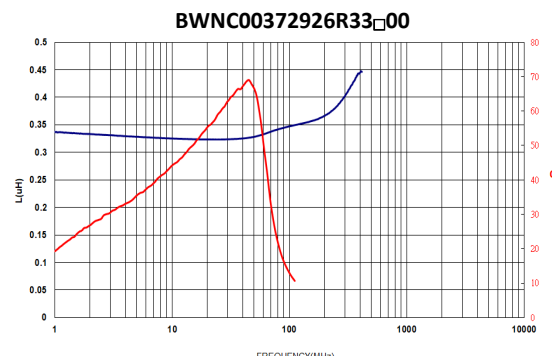
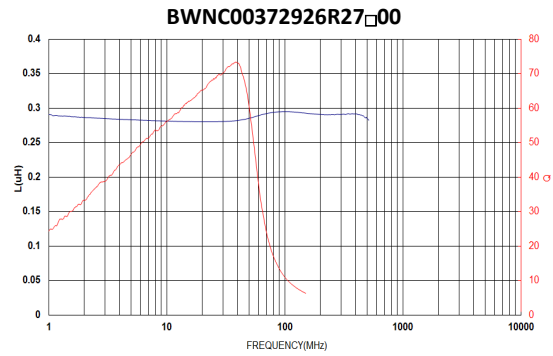
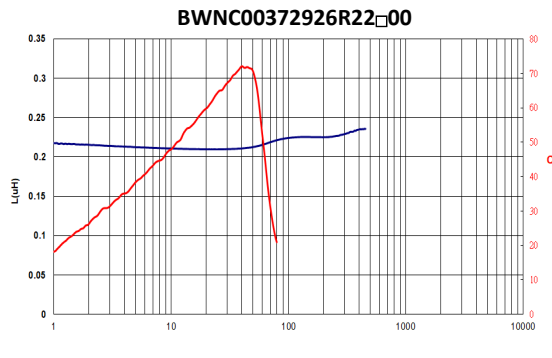
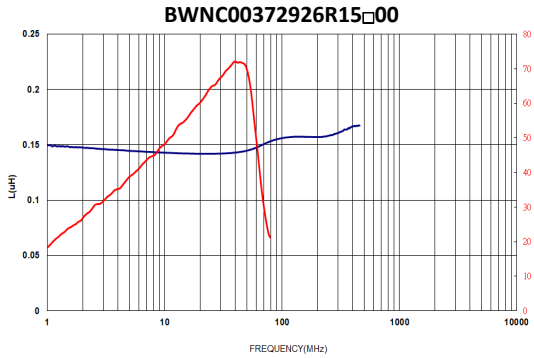

BWNC00372926 Series Specification

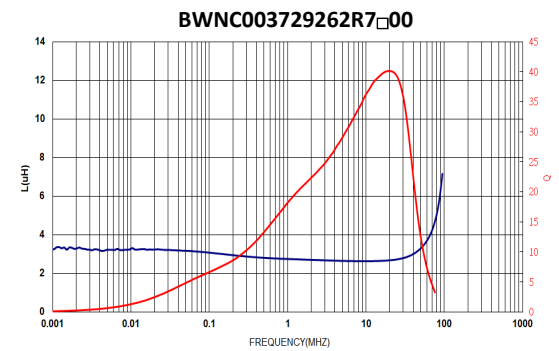
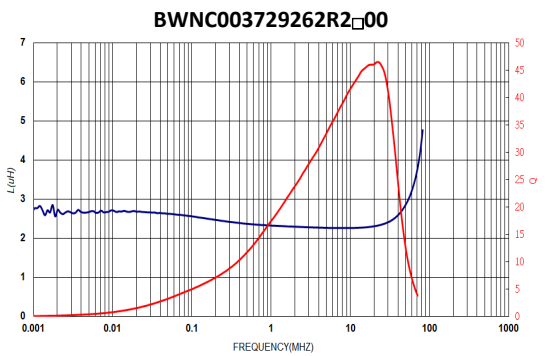
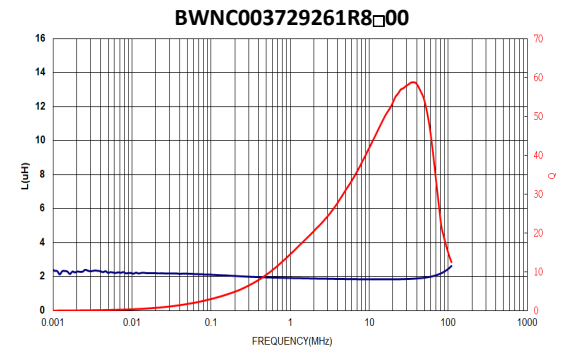
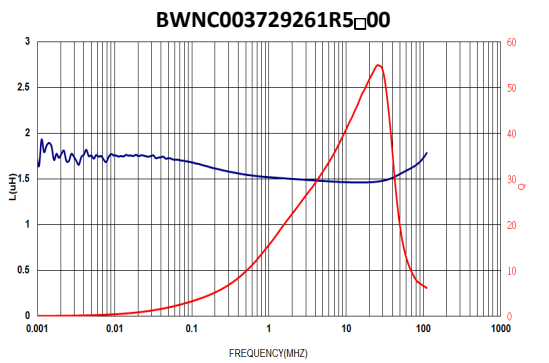
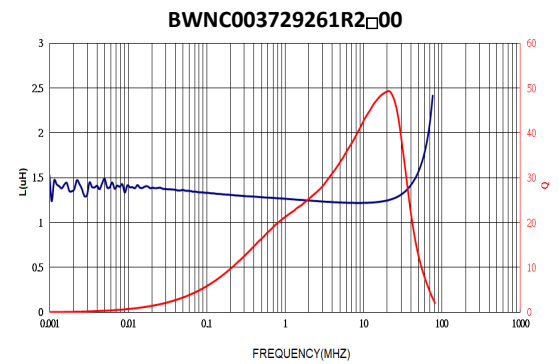
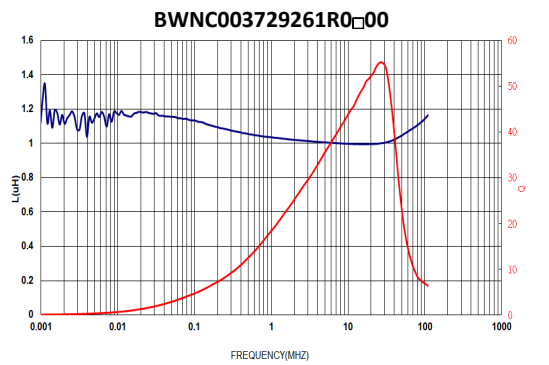
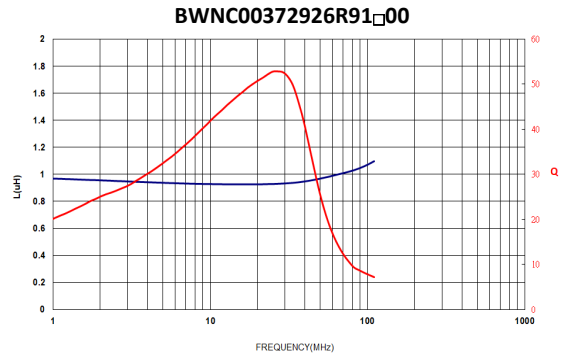
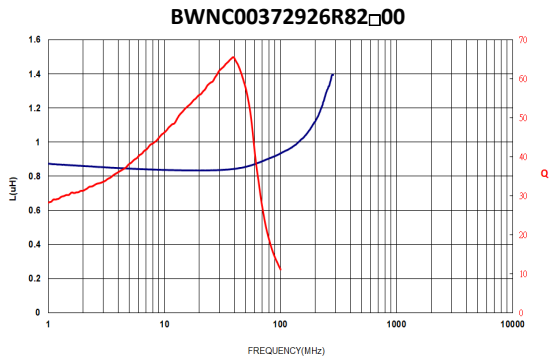

BWNC00372926 Series Specification

BWNC003729263R3□00

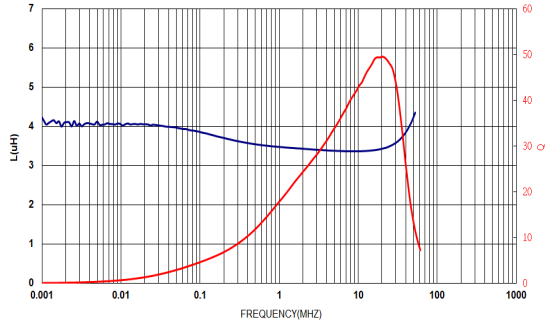

BWNC003729263R9□00

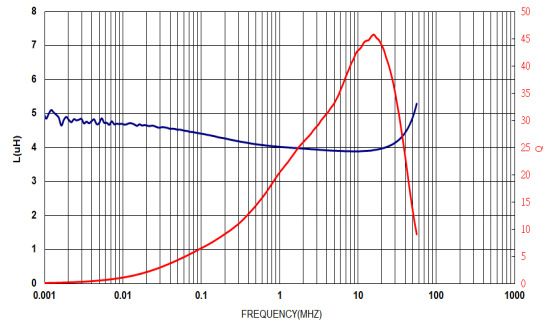

BWNC003729264R7□00

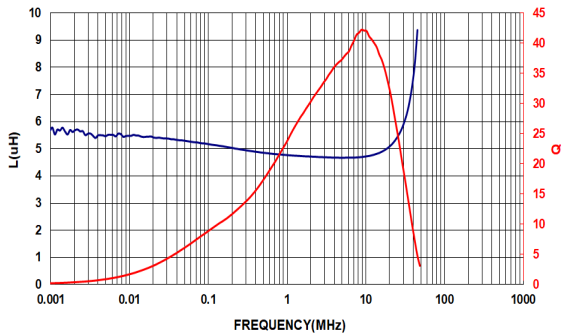

BWNC003729265R6□00

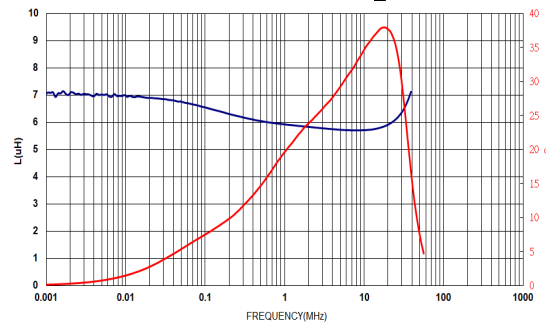

BWNC003729266R8□00

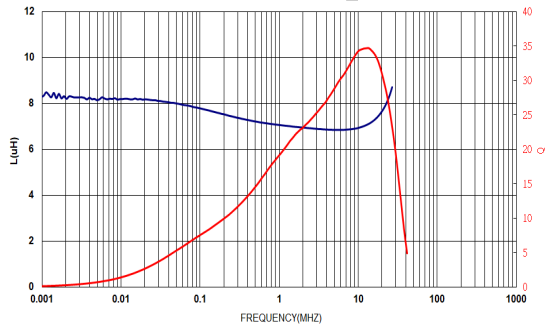

BWNC003729268R2□00

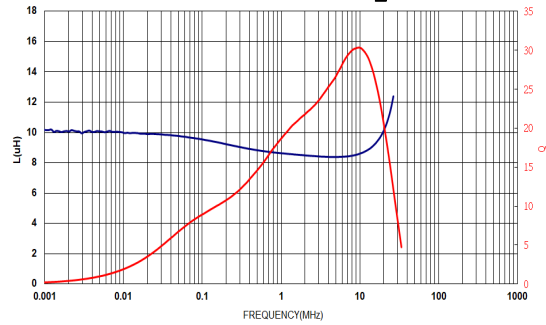

BWNC0037292610□00

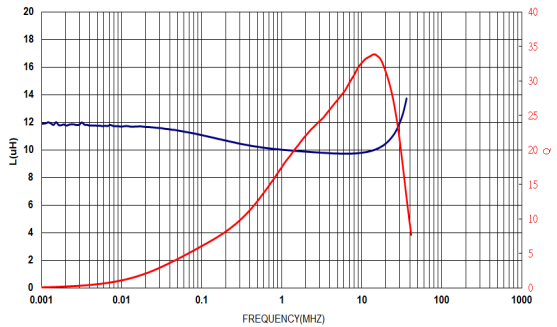

BWNC0037292612□00

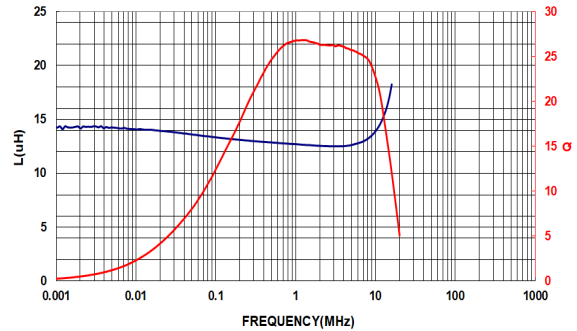

BWNC00372926 Series Specification

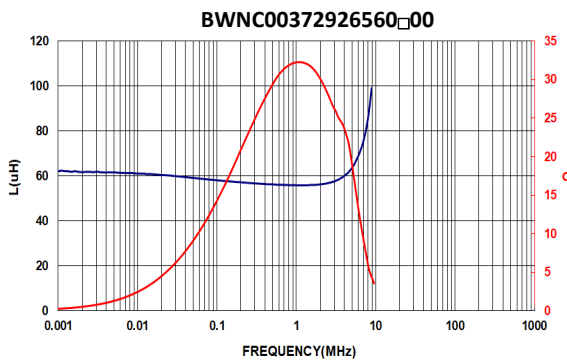
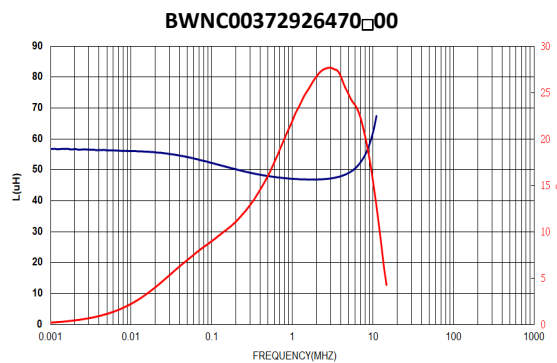
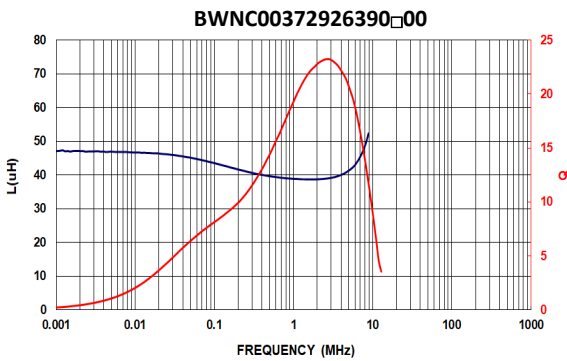
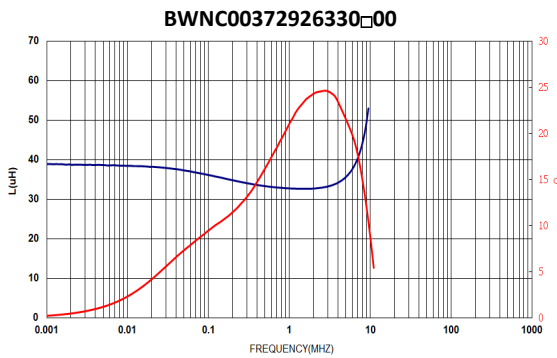
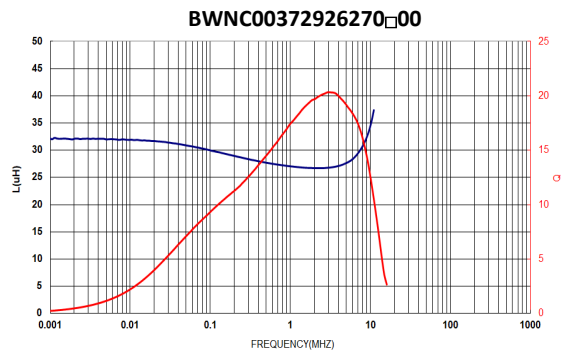
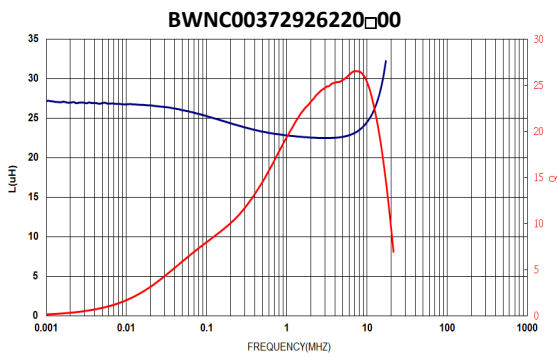
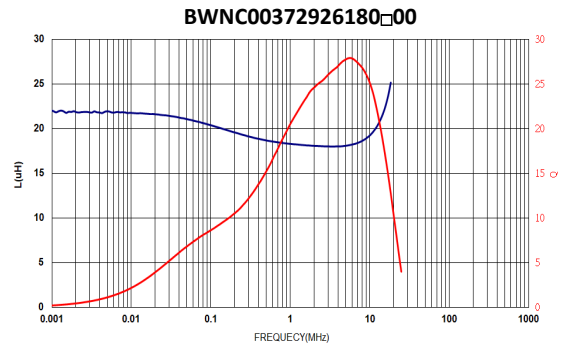
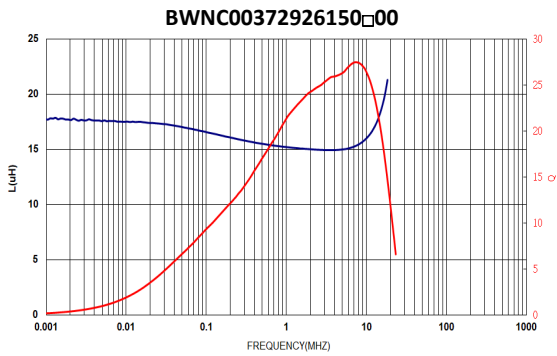

BWNC00372926 Series Specification

BWNC00372926680□00

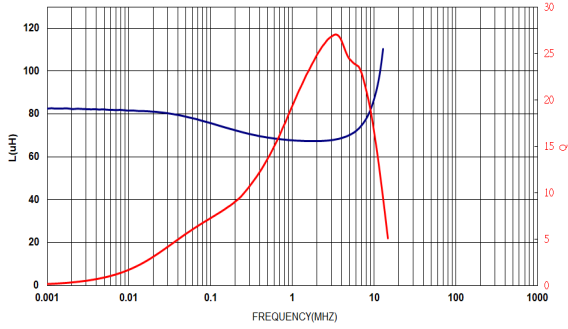

BWNC00372926820□00

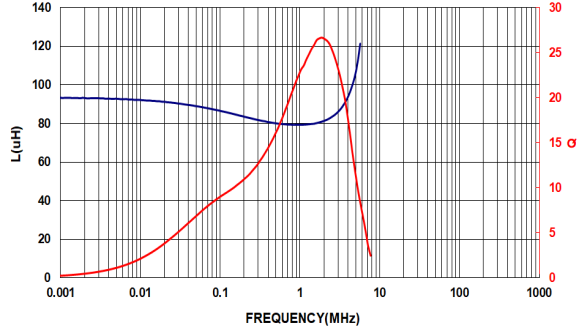

BWNC00372926101□00

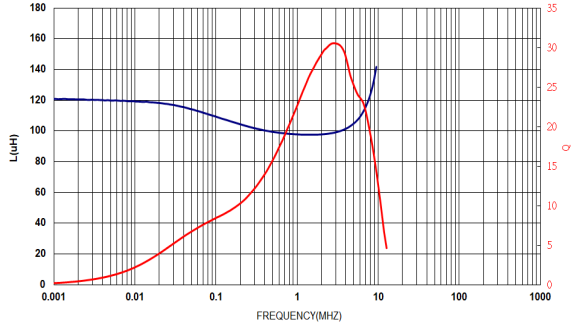

BWNC00372926151□00

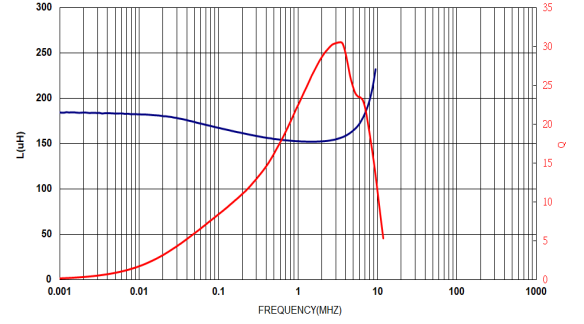

BWNC00372926181□00

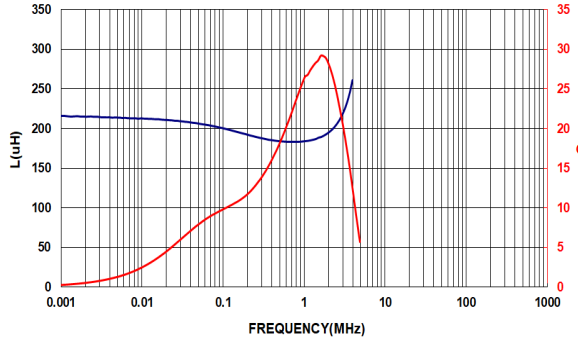

BWNC00372926221□00

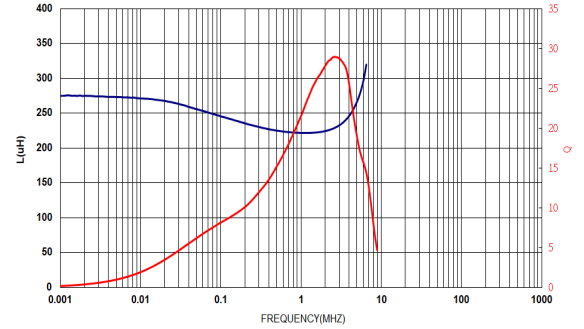

BWNC00372926331□00

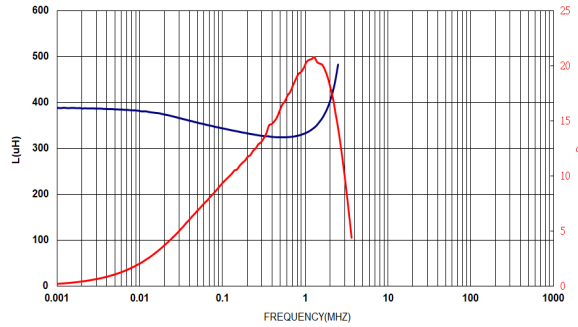

BWNC00372926391□00

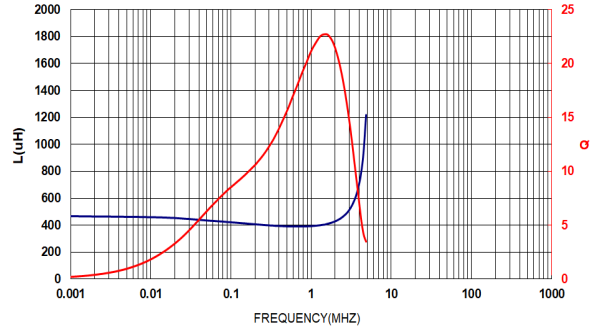

BWNC00372926 Series Specification

