

# High Isolation Power Transformers

Extended Creepage Toroidal Platform SMD - PMT6397.XXXNLT

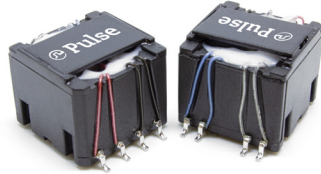

- Ⓢ Push Pull Transformer
- Ⓢ Reinforced insulation for isolated power supply driver
- Ⓢ 17.6mm creepage and 13mm clearance
- Ⓢ 5KVrms isolation (Up to 1500Vpk rated voltage)<sup>6</sup>
- Ⓢ Automotive grade<sup>6</sup>

## Electrical Specifications @ 25°C - Operating Temperature -40°C to +125°C

Part Number	Inductance (1-2) (μH Min)	Leakage Inductance <sup>3</sup> (μH MAX)	DCR (1-2)=(3-4) (Ω MAX)	DCR (5-6)=(7-8) (Ω MAX)	ET MAX (1-2) <sup>1</sup> (V-μsec MAX)	CAP <sup>3</sup> (pF MAX)	Turns Ratio (1-4):(8-5)	Isolated Voltage (Vrms)
PMT6397.011NLT	140	12.0	0.70	0.7	54	8.0	1CT : 1CT	5000
PMT6397.013NLT	70	7.0	0.50	1.2	38	7.5	1CT : 3CT	
PMT6397.034NLT	115	11.0	0.65	0.8	48	8.0	3CT : 4CT	

- Notes:**
- The ET Max is calculated to limit the core loss and temperature rise at 300KHz based on a bipolar flux swing of 180mT Peak.
  - The applied ET may need to be further derated for higher frequencies based on the temperature rise which results from the core and copper losses
    - To calculate total copper loss (W), use the following formula:  
 $Copper\ Loss\ (W) = I_{rms\_Primary}^2 * DCR\_Primary + I_{rms\_Secondary}^2 * DCR\_Secondary$
    - To calculate total core loss (W), use the following formula:  
 $Core\ Loss\ (W) = 6.74 * 10^{-8} * (Frequency\ in\ kHz)^{1.38} * (180 * [ET/ET\ Max])^{2.864}$   
 Where ET is the applied Volt Second, ET Max is the rated Volt Second for 180mT flux swing
    - To calculate temperature rise, use the following formula: Temperature Rise (°C) =  
 $93 * (Core\ Loss(W) + Copper\ Loss(W))$
  - Leakage Inductance : (1-4) with (5-8) shorted, 2,3 & 6-7 tied. Capacitance : 1,3 to 6,8.
  - Creepage and clearance is in accordance with IEC 61558-1 and IEC61558-2-16 for reinforced insulation to a working voltage of 880Vrms (for basic insulation to a working voltage of 1760Vrms) based on material group III, pollution degree 2, OVC II and 5000m altitude.
  - Rated voltage is based on a positive partial discharge test (discharge < 10pC) for the profile shown in page 3, in accordance with IEC60664 for basic insulation. In an application which requires a reinforced insulation barrier, a rated voltage of 1200Vpk is defined and confirmed by partial discharge testing.
  - Pending AEC-Q200 qualification and IATF launch. Ⓢ

## Mechanical

## Schematic

### PMT6397.XXXNLT

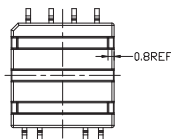
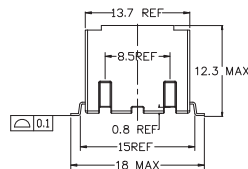
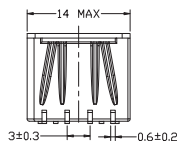
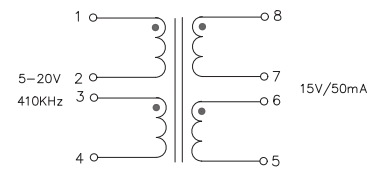
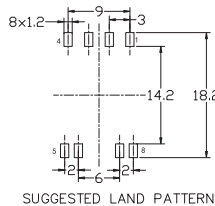
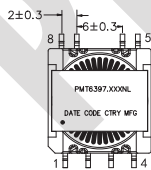

FINAL OUTLINE

Weight .....3.9grams  
Tape & Reel .....150/reel

Dimensions:  $\frac{\text{Inches}}{\text{mm}}$

Unless otherwise specified,  
all tolerances are  $\pm \frac{.010}{0,25}$

## TAPE & REEL INFO

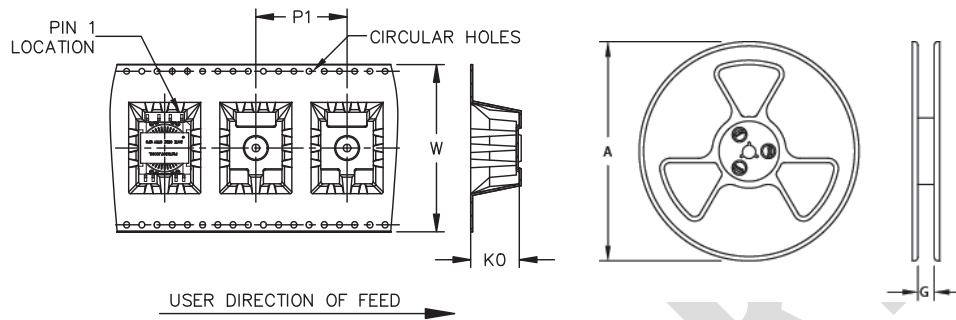

### SURFACE MOUNTING TYPE, REEL/TAPE LIST

PART NUMBER	REEL SIZE (mm)		TAPE SIZE (mm)			QTY
	A	G	P <sub>1</sub>	W	K <sub>0</sub>	PCS/REEL
PMT6397.XXXNLT	Ø330	44.4	24	44	12.8	150

## APPLICATION

PMT6397.XXXNLT is a series of high isolation power supply transformer drivers. Intended to operate in a fixed duty cycle Push Pull topology, it is a part of a low cost solution for delivering lower power (up to 3W) from a low voltage source. A typical implementation would be an isolated automotive power supply driver circuit, the design is compatible with the TI SN6501-Q1, along with many other automotive grade push pull drivers. A schematic diagram for the Push Pull converter topology is given below.

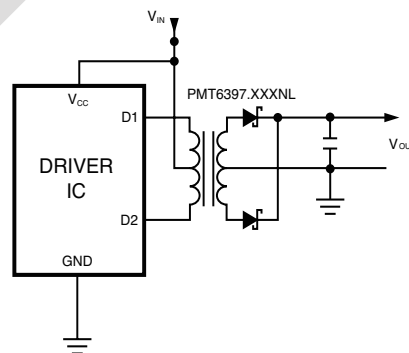

For a fixed 50% duty cycle mode of operation, the output voltage is simply determined by the input voltage and turns ratio. The 1:3 ratio is intended to deliver up to 15V from a 5V source. Other turns ratios can be made available on request.

The distinguishing feature of the PMT6397 series is the segmented winding on the toroidal core. In addition to providing the reinforced insulation, the triple insulated wire in this winding construction provides enhanced electrical isolation, offering up to 1500Vpk rated voltage, making it suitable for high battery voltage automotive applications.

# High Isolation Power Transformers

Extended Creepage Toroidal Platform SMD - PMT6397.XXXNLT

## Test Procedure Setting

### PD - MV no.2

U inc.:  
yes

U ext.:  
yes

Limit:  
10 pC

Range:  
AUTO

## Basic Insulation - Partial Discharge Test Passed

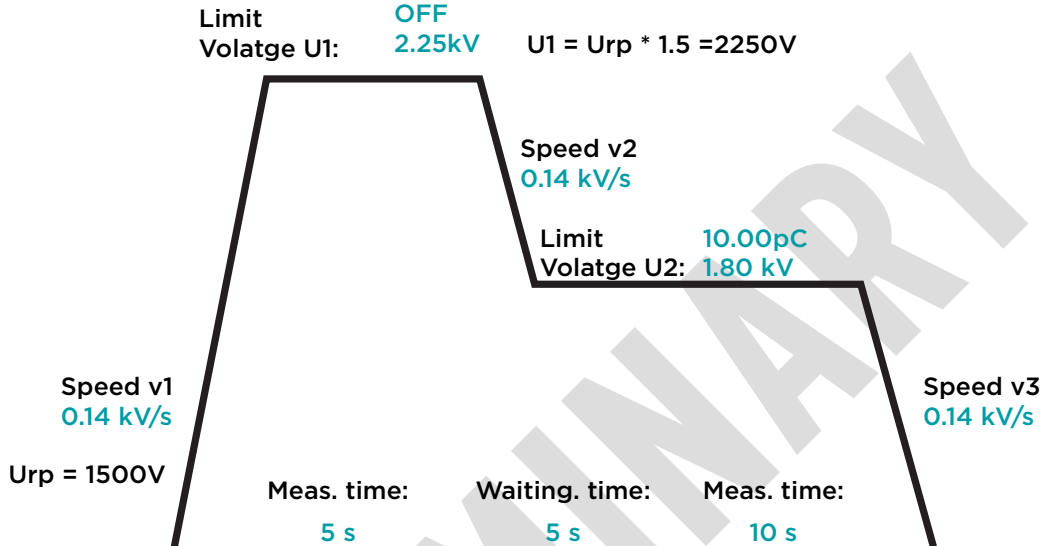

## Test Procedure Setting

### PD - MV no.2

U inc.:  
yes

U ext.:  
yes

Limit:  
10 pC

Range:  
AUTO

## Reinforced Insulation - Partial Discharge Test Passed

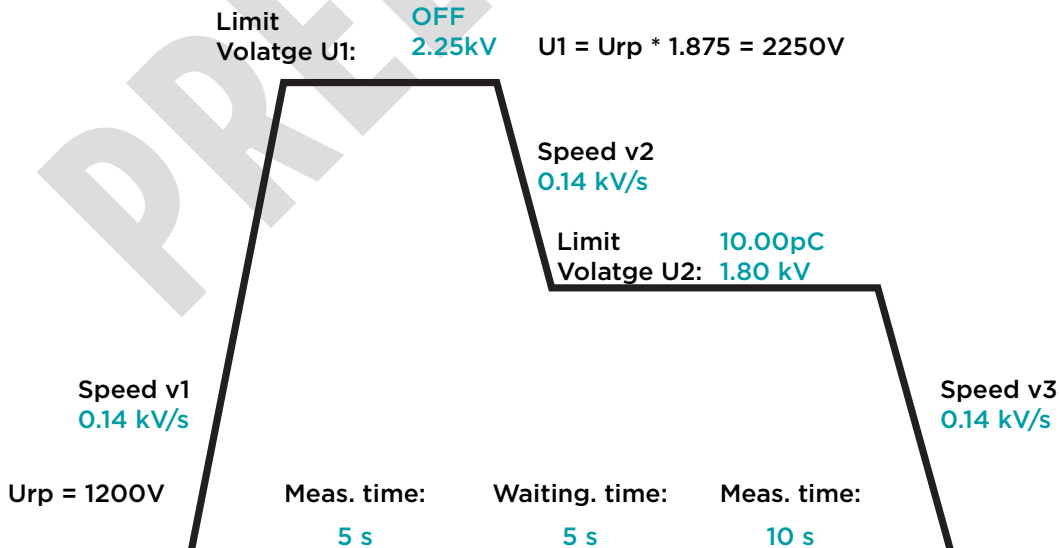

## For More Information:

Americas - [prodinfo\\_power\\_americas@yageo.com](mailto:prodinfo_power_americas@yageo.com) | Europe - [prodinfo\\_power\\_emea@yageo.com](mailto:prodinfo_power_emea@yageo.com) | Asia - [prodinfo\\_power\\_asia@yageo.com](mailto:prodinfo_power_asia@yageo.com)

Performance warranty of products offered on this data sheet is limited to the parameters specified. Data is subject to change without notice. Other brand and product names mentioned herein may be trademarks or registered trademarks of their respective owners. © Copyright, 2024. Pulse Electronics, Inc. All rights reserved.

YAGEO Corporation and its affiliates do not recommend the use of commercial or automotive grade products for high reliability applications or manned space flight.