

- ④ 3W LLC 3 winding SiC drive transformer
- ④ Functional Insulation, 3000Vrms
- ④ Rated Voltage: 1300Vpk<sup>3</sup>
- ④ Footprint: 16 x 15 mm Max
- ④ Height: 5mm Max

**Electrical Specifications @ 25°C - Operating Temperature -40°C to +125°C**

Part Number	Inductance Pri (uH Min)	Leakage Inductance (uH Max)	Capacitance Pri to Sec (pF Max)	DCR Pri (Ω Max)	DCR Sec (Ω Max)	E*T(3-4) <sup>1</sup> (V*uSec Max)	Turns Ratio ±3.0%	Hi-Pot Voltage (Vrms)
PMG7277NLT	29	3.3	2.8	0.23	1.24	18	1: 3.77	3000

**Notes:**

1. The ET Max is calculated to limit the core loss and temperature rise at 300KHz, based on a bipolar flux swing of 180mT Peak.
2. The applied ET may need to be further derated for higher frequencies based on the temperature rise which results from the core and copper losses
  - A. To calculate total copper loss (W), use the following formula:  
Copper Loss (W)=I<sub>rms\_Primary</sub><sup>2</sup>\*DCR\_Primary+I<sub>rms\_Secondary</sub><sup>2</sup>\*DCR\_Secondary\*3
  - B. To calculate total core loss (W), use the following formula:  
Core Loss(W) = 3.08E-9\*f<sup>1.878</sup>\*E\*T<sup>2.52</sup>
3. Where f is the working frequency in KHz, E\*T is the voltage\*times in V\*uSecond,
  - C. To calculate temperature rise, use the following formula: Temperature Rise (°C)  
=70\*(Core Loss(W)+Copper Loss (W))
4. Rated voltage is based on a positive partial discharge test (discharge < 10pC) during the design phase (not production tested) for a 1300V repetitive peak voltage (U<sub>rp</sub>). The test condition was with an inception voltage, U<sub>1</sub> = 1.5\*U<sub>rp</sub>, followed by an extinction voltage, U<sub>2</sub> = 1.2\* U<sub>rp</sub>
5. This product is automotive ready, but has not completed AEC-Q200 qualification testing. Please contact your Yageo representative to discuss your IATF requirements

Mechanical

Schematic

PMG7277NLT

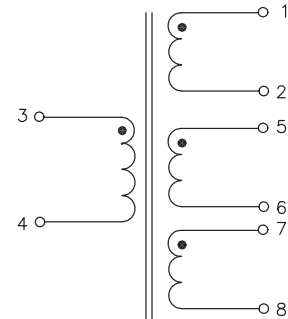
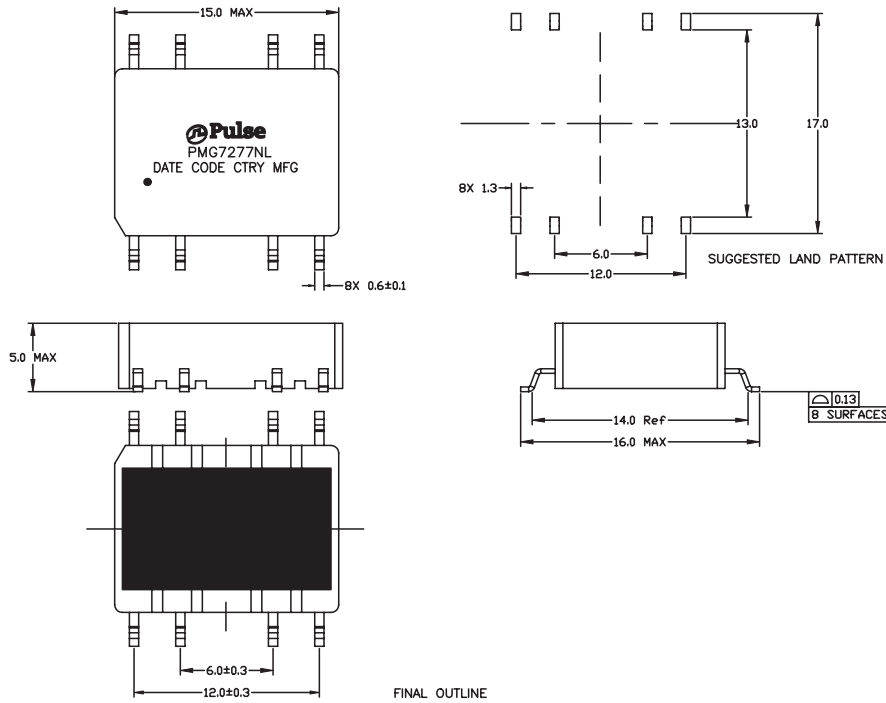

SCHEMATIC

Dimensions: mm

Unless otherwise specified, all tolerances are  
.x = ±0.25  
.xx = ±0.13

TAPE & REEL INFO

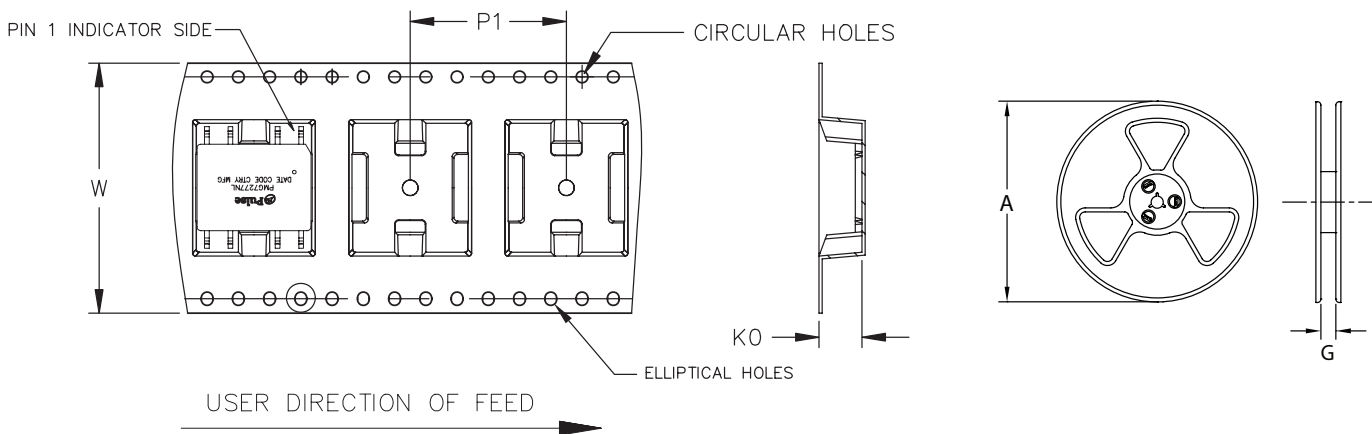

SURFACE MOUNTING TYPE, REEL/TAPE LIST

PART NUMBER	REEL SIZE (mm)		TAPE SIZE (mm)			QTY
	A	G	P <sub>1</sub>	W	K <sub>0</sub>	PCS/REEL
PHT7249NLT	Ø330	32.4	20	32	5.5	500

Application Note

Flyback and Push-Pull topologies have been widely used for MOSFET drive circuits. Tight coupling is necessary to minimise transformer leakage inductance, which enhances the efficiency of the drive circuit. However a tightly coupled transformer design results in relatively high interwinding capacitance, limiting higher switching frequency and the full utilisation of the benefits of using SiC Mosfets. Thus, it is difficult to simultaneously have low leakage inductance and low interwinding capacitance in a transformer.

This points to the significant benefit when using the LLC topology where a relatively high leakage inductance can be used as part of the resonant circuit, even replacing the need for an external resonant inductor. PMG7277NLT implements a multi-segment winding construction, which naturally minimizes the interwinding capacitance while the leakage inductance increases to a level which contributes to the resonant inductance. The low capacitance enables an order of magnitude reduction in the common-mode current injection through the bias transformer, making this solution ideal for high frequency switching SiC Mosfet drive circuits. The soft-switching feature further reduces the EMI noise.

The below circuit shows how the LLC transformer can be used to provide positive and negative voltages for SiC device switching. The voltage required across the gate-source terminals of a SiC MOSFET is typically in the range of 14 to 20 V for full turn-on and 0 to -5 V for robust turn-off. PMG7277NLT is suitable for this circuit and compatible with LLC controllers such as the TI UCC25800-Q1 to simultaneously drive 3 SiC Mosfets

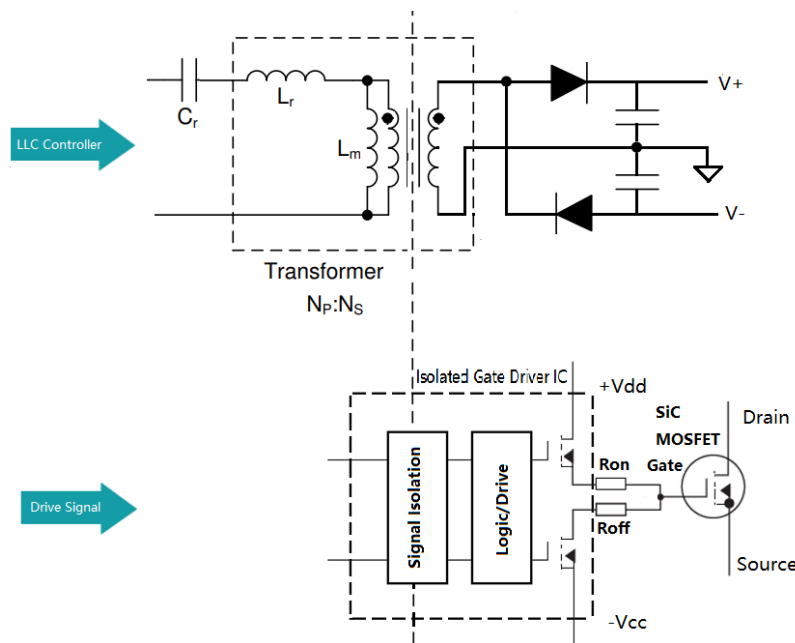

An additional benefit of the segmented windings is a high (3000Vrms) isolation between winding segments. PMG7277NLT has a 1300Vpk rated voltage between primary & secondary windings and between each pair of secondary windings. Contact your Yageo representative for other required output voltage and safety requirements