

Overview

KEMET's PEG124 is an electrolytic capacitor with very long-life and outstanding electrical performance. The device has a polarized all-welded design, tinned copper wire leads, a negative pole connected to the case, and plastic insulation. Long-life and very high reliability are achieved by dimensioning of the capacitor, careful selection of materials/methods, and discipline in quality control allowing operation up to +125°C/+105°C.

The PEG124 winding is housed in a cylindrical aluminum can, with a high purity aluminum lid and high quality rubber gasket. The sealing system is designed for electrolyte leakage-free operation and a very low gas-diffusion rate of electrolyte. The low ESR is the result of a low resistive electrolyte/paper system and an all-welded design.

Applications

KEMET's PEG124 is a high performance axial electrolytic capacitor. Typical applications include smoothing, coupling/decoupling and energy storage in telecommunication, power supply system, data processing, process control and measuring, where long life and high reliability are of paramount importance.

Benefits

- Operating temperature of +125°C and +105°C
- Very long life, up to 27,500 hours at +105°C
- Low ESR
- Low ESL
- Polarized all-welded design
- Outstanding electrical performance



Part Number System

PEG124	E		F	410	0	Q	E4
Series	Rated Voltage (VDC)		Size Code	Capacitance Code (µF)	Version	Capacitance Tolerance	Packaging
Axial Aluminum Electrolytic	E = 10 G = 16 H = 25 K = 40 M = 63	P = 100 R = 200 U = 350 V = 400 Y = 450	See Dimension Table	The last two digits represent significant figures. The first digit indicates the total number digits.	0 = Standard A - Z = High Performance	Q = -10 +30% M = ±20% T = -10 +50%	See Ordering Options Table

Performance Characteristics

Item	Performance Characteristics	
Capacitance Range	10 - 680 μ F	1 - 470 μ F
Rated Voltage	10 - 63 VDC	100 - 450 VDC
Operating Temperature	-40 to +125°C	-40 to +105°C
Capacitance Tolerance	-10/+30%, (-10/+50%, \pm 20% select values) at 100 Hz/+20°C	
Operational Lifetime	27,500 hours at +105°C (hours, D = 20 mm)	
Shelf Life	5,000 hours at +105°C or 10 years at +40°C 0 VDC +40°C 10 years 0 VDC	
Leakage Current	I = 0.01 CV (μ A, CV \leq 1,000) I = 0.003 CV + 4.0 (μ A, CV > 1,000)	I = 0.006 CV + 4.0 (μ A)
	C = rated capacitance (μ F), V = rated voltage (VDC). Voltage applied for 5 minutes at +20°C.	
Vibration Test Specifications	Procedure	Requirements
	0.75 mm displacement amplitude or 10 g maximum acceleration. Vibration applied for three 2-hour sessions at 10 - 500 Hz (capacitor clamped by body).	No leakage of electrolyte or other visible damage. Deviations in capacitance from initial measurements must not exceed: Δ C/C < 5%
Standards	IEC 60384-4 long life grade 40/125/56	IEC 60384-4 long life grade 40/105/56

Compensation Factor of Ripple Current (RC) vs. Frequency

Frequency	300 Hz	1 kHz	5 kHz	100 kHz
Coefficient	0.57	0.80	1.00	1.04

Test Method & Performance

Endurance Life Test		
Conditions	Performance	
Temperature	+125°C	+105°C (\geq 100 V)
Test Duration	2,000 hours	5,000 hours
Ripple Current	Maximum ripple current specified in table	
Voltage	The sum of DC voltage and the peak AC voltage must not exceed the rated voltage of the capacitor	
Performance	The following specifications will be satisfied when the capacitor is tested at +20°C:	
Capacitance Change	< 160 V	Within 15% of the initial value
	\geq 160 V	Within 10% of the initial value
Equivalent Series Resistance	Does not exceed 200% of the initial value	
Leakage Current	Does not exceed leakage current limit	

Ordering Options Table

Case Size	Packaging Kind	Lead Length (mm)	Lead and Packaging Code
Standard Bulk Packaging Options			
All	Bulk (box)	42 +3/-2	L1 (Obsolete)
≤ 13 x 37	T and R	See Dimension Table	T1
All	Tray	42 +3/-2	E4

Dimensions – Millimeters

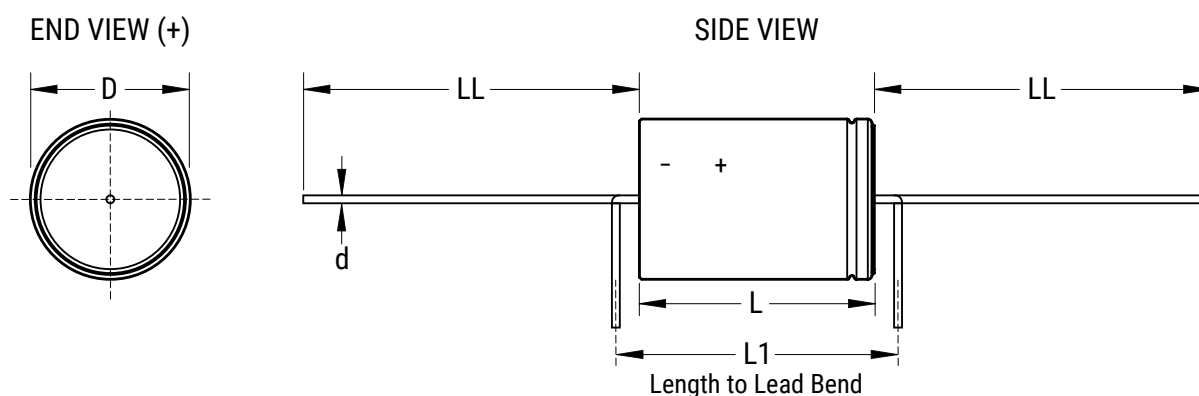

Size Code	Dimensions in mm				Tray	Taped	Approximate Weight Grams
	D	L	L1	d	LL	LL	
	±0.5	±1	Minimum	±0.03	+3/-2	+3/-2	
A	10	20.0	26.0	0.8	42	31	3
B	10	29.0	35.0	0.8	42	27	4
C	13	20.0	26.0	0.8	42	31	4
D	13	29.0	35.0	0.8	42	27	6
E	13	37.0	43.0	0.8	42	24	7
F	16	29.0	35.0	0.8	42		8
G	16	37.0	43.0	0.8	42		11
H	20	29.0	35.0	0.8	42		13
J	20	37.0	43.0	0.8	42		20
L	20	46.0	52.0	0.8	42		24

Note: L1 is KEMET's recommendation for minimum distance between symmetrical lead bend. Available only for customer specific part numbers. Lead bend dimensions must be specified and confirmed per article.

Shelf Life

The capacitance, ESR and impedance of a capacitor will not change significantly after extended storage periods, however the leakage current will very slowly increase. KEMET products are particularly stable and allow a shelf life in excess of ten years at 40°C. See sectional specification under each product series for specific data.

Failure Rate

Estimated field failure rate: ≤ 1.0 ppm (failures per year/produced number of capacitors per year).
The expected failure rate for this capacitor range is based on field experience for capacitors with structural similarity.

Environmental Compliance



All Part Numbers in this datasheet are Reach and RoHS compliant and Halogen-Free.

As an environmentally conscious company, KEMET is working continuously with improvements concerning the environmental effects of both our capacitors and their production.

In Europe (RoHS Directive) and in some other geographical areas such as China, legislation has been put in place to prevent the use of some hazardous materials, such as lead (Pb), in electronic equipment. All products in this catalog are produced to help our customers' obligations to guarantee their products and fulfill these legislative requirements. The only material of concern in our products has been lead (Pb), which has been removed from all designs to fulfill the requirement of containing less than 0.1% of lead in any homogeneous material. KEMET will closely follow any changes in legislation worldwide and make any necessary changes in its products, whenever needed.

Some customer segments such as medical, military and automotive electronics may still require the use of lead in electrode coatings. To clarify the situation and distinguish products from each other, a special symbol is used on the packaging labels for RoHS compatible capacitors.

Due to customer requirements, there may appear additional markings such as lead-free (LF), or lead-free wires (LFW) on the label.

Table 1A – Ratings & Part Number Reference

125°C										
VDC	Rated Capacitance	Size Code	Case Size D x L (mm)	Ripple Current			ESR		L _{ESL}	Part Number
				Maximum	Rated		Maximum		Approximate	
				100 Hz 125°C (A)	≥ 5 kHz 60°C (A)	≥ 5 kHz 125°C (A)	100 Hz 20°C (mΩ)	100 kHz 20°C (mΩ)	(nH)	
16	68	A	10 x 20	0.13	0.95	0.36	2400	1600	5	PEG124GA2680Q(1)
16	100	A	10 x 20	0.191	1.2	0.45	1700	1100	5	PEG124GA3100Q(1)
16	150	B	10 x 29	0.287	1.5	0.61	1100	710	6	PEG124GB3150Q(1)
16	220	B	10 x 29	0.315	1.5	0.7	800	540	6	PEG124GB3220Q(1)
16	220	C	13 x 20	0.422	3.9	1.4	390	140	6	PEG124GC322AQ(1)
16	330	D	13 x 29	0.515	2.6	1.1	500	330	8	PEG124GD3330Q(1)
16	470	C	13 x 20	0.645	3.9	1.5	250	120	6	PEG124GC347AQ(1)
16	470	D	13 x 29	0.632	3.1	1.1	370	250	8	PEG124GD3470Q(1)
16	680	E	13 x 37	0.851	4.6	1.7	200	120	10	PEG124GE3680Q(1)
25	47	A	10 x 20	0.141	1.1	0.44	2400	1300	5	PEG124HA2470Q(1)
25	100	B	10 x 29	0.255	1.5	0.56	1200	670	6	PEG124HB3100Q(1)
25	220	C	13 x 20	0.452	3.1	1.2	460	200	6	PEG124HC322AQ(1)
25	220	D	13 x 29	0.448	2.6	0.96	590	320	8	PEG124HD3220Q(1)
25	330	C	13 x 20	0.525	3.1	1.2	370	200	6	PEG124HC333AQ(1)
25	330	E	13 x 37	0.57	3.4	1.2	360	200	10	PEG124HE3330Q(1)
40	33	A	10 x 20	0.153	1.1	0.39	2900	1300	5	PEG124KA2330Q(1)
40	68	B	10 x 29	0.221	1.5	0.56	1400	650	6	PEG124KB2680Q(1)
40	150	C	13 x 20	0.381	3.1	1.2	580	200	6	PEG124KC315AQ(1)
40	150	D	13 x 29	0.416	2.8	1	620	290	8	PEG124KD3150Q(1)
40	220	C	13 x 20	0.452	3.1	1.2	440	200	6	PEG124KC322AQ(1)
40	220	E	13 x 37	0.487	3.5	1.3	440	190	10	PEG124KE3220Q(1)
63	10	A	10 x 20	0.076	0.9	0.35	5900	1600	5	PEG124MA2100Q(1)
63	15	A	10 x 20	0.113	1	0.39	4300	1400	5	PEG124MA2150Q(1)
63	22	A	10 x 20	0.134	1.1	0.43	3400	1200	5	PEG124MA2220Q(1)
63	33	B	10 x 29	0.158	1.4	0.53	2200	780	6	PEG124MB2330Q(1)
63	47	B	10 x 29	0.19	1.6	0.57	1600	550	6	PEG124MB2470Q(1)
63	68	D	13 x 29	0.274	2.3	0.89	1100	400	8	PEG124MD2680Q(1)
63	100	D	13 x 29	0.355	3	1	740	260	8	PEG124MD3100Q(1)
63	100	C	13 x 20	0.328	3.1	1	730	220	6	PEG124MC310AQ(1)
63	150	D	13 x 29	0.455	3.6	1.4	460	150	8	PEG124MD315AQ(1)
VDC	Rated Capacitance	Size Code	Case Size	Ripple Current			ESR		L _{ESL}	Part Number

(1) Insert packaging code. See Ordering Options Table for available options.

Table 1B – Ratings & Part Number Reference

105°C										
VDC	Rated Capacitance	Size Code	Case Size	Ripple Current			ESR		L _{ESL}	Part Number
				Maximum	Rated		Maximum		Approximate	
	120 Hz 20°C (µF)		D x L (mm)	100 Hz 105°C (A)	≥ 5 kHz 60°C (A)	≥ 5 kHz 105°C (A)	100 Hz 20°C (mΩ)	100 kHz 20°C (mΩ)	(nH)	
100	4.7	A	10 x 20	0.05	0.65	0.20	16000	2800	5	PEG124PA147CQ(1)
100	22	B	10 x 29	0.122	1.24	0.37	3000	1100	6	PEG124PB222VQ(1)
100	47	D	13 x 29	0.206	1.90	0.58	1500	540	8	PEG124PD247VQ(1)
100	47	E	13 x 37	0.192	1.50	0.45	1800	920	10	PEG124PE247CQ(1)
200	10	B	10 x 29	0.065	0.47	0.17	10000	4200	6	PEG124RB2100Q(1)
200	15	D	13 x 29	0.096	0.74	0.26	6300	2400	8	PEG124RD2150Q(1)
200	22	D	13 x 29	0.12	0.86	0.31	4600	1900	8	PEG124RD2220Q(1)
200	33	F	16 x 29	0.167	1.20	0.42	3100	1300	10	PEG124RF2330Q(1)
200	47	F	16 x 29	0.21	1.50	0.53	2200	920	10	PEG124RF2470Q(1)
200	68	H	20 x 29	0.294	2.00	0.71	1500	660	12	PEG124RH2680Q(1)
200	100	J	20 x 37	0.353	2.40	0.88	1000	440	15	PEG124RJ3100Q(1)
200	150	L	20 x 46	0.446	3.10	1.10	690	300	17	PEG124RL3150Q(1)
350	4.7	B	10 x 29	0.055	0.37	0.14	17000	7500	6	PEG124UB1470Q(1)
350	6.8	D	13 x 29	0.092	0.59	0.22	9000	4200	8	PEG124UD1680Q(1)
350	10	D	13 x 29	0.102	0.65	0.24	7600	3600	8	PEG124UD2100Q(1)
350	22	F	16 x 29	0.184	1.20	0.44	3300	1500	10	PEG124UF2220Q(1)
350	33	H	20 x 29	0.248	1.60	0.56	2300	1100	12	PEG124UH2330Q(1)
350	47	J	20 x 37	0.328	2.10	0.77	1500	660	15	PEG124UJ2470Q(1)
350	68	L	20 x 46	0.389	2.50	0.91	1100	500	17	PEG124UL2680Q(1)
400	2.2	B	10 x 29	0.042	0.27	0.11	25000	12000	6	PEG124VB1220Q(1)
400	4.7	D	13 x 29	0.078	0.52	0.21	11000	5100	8	PEG124VD1470Q(1)
400	10	E	13 x 37	0.116	0.70	0.26	5900	3000	10	PEG124VE2100Q(1)
400	22	G	16 x 37	0.209	1.40	0.50	2700	1200	12	PEG124VG2220Q(1)
400	33	J	20 x 37	0.304	1.90	0.71	1600	760	15	PEG124VJ2330Q(1)
400	47	L	20 x 46	0.377	2.40	0.89	1200	530	17	PEG124VL2470Q(1)
450	1.0	A	10 x 20	0.03	0.21	0.08	49000	20000	5	PEG124YA1100Q(1)
450	2.2	B	10 x 29	0.043	0.29	0.11	24000	11000	6	PEG124YB1220Q(1)
450	3.3	B	10 x 29	0.055	0.38	0.14	17000	7300	6	PEG124YB1330Q(1)
450	4.7	D	13 x 29	0.079	0.54	0.20	11000	4800	8	PEG124YD1470Q(1)
450	6.8	D	13 x 29	0.097	0.61	0.22	8300	4000	8	PEG124YD1680Q(1)
450	10	F	16 x 29	0.133	0.82	0.40	5700	2800	10	PEG124YF2100Q(1)
450	10	F	16 x 29	0.141	1.40	0.30	4600	1700	10	PEG124YF210AT(1)
450	15	G	16 x 37	0.171	1.10	0.41	3600	1700	12	PEG124YG2150Q(1)
450	15	H	20 x 29	0.185	1.60	0.49	3300	1400	12	PEG124YH215AQ(1)
450	22	H	20 x 29	0.24	1.60	0.56	2400	1100	12	PEG124YH2220Q(1)
450	22	J	20 x 37	0.242	2.30	0.67	2100	800	15	PEG124YJ222AT(1)
450	33	J	20 x 37	0.306	2.00	0.72	1600	740	15	PEG124YJ2330Q(1)
450	47	L	20 x 46	0.377	2.40	0.89	1200	530	17	PEG124YL2470Q(1)
VDC	Rated Capacitance	Size Code	Case Size	Ripple Current			ESR		L _{ESL}	Part Number

(1) Insert packaging code. See Ordering Options Table for available options.

Operational Life PEG124 (+125°C)

Operational life (L_{op}) at ambient temperature T_a and ripple current I_{AC} .

Diagram valid for 20 mm case size.

Operational life,

16 mm case size: 0.67 x diagram value

13 mm case size: 0.44 x diagram value

10 mm case size: 0.37 x diagram value

Example:

Article: PEG124MG368AQ (16 x 37 mm)

Ambient temperature (T_a): +85°C

Ripple current at 10 kHz (I_{AC}): 6.0 A

I_{RAC} (+125°C ≥ 5 kHz) = 2.6 A (from data table)

→ I_{AC}/I_{RAC} (+125°C) = 2.3

Operational life: interpolation between the

L_{op} -curves → $L_{op} \sim 20 \text{ kh} \times 0.67 = 13 \text{ kh}$ (blue curves)

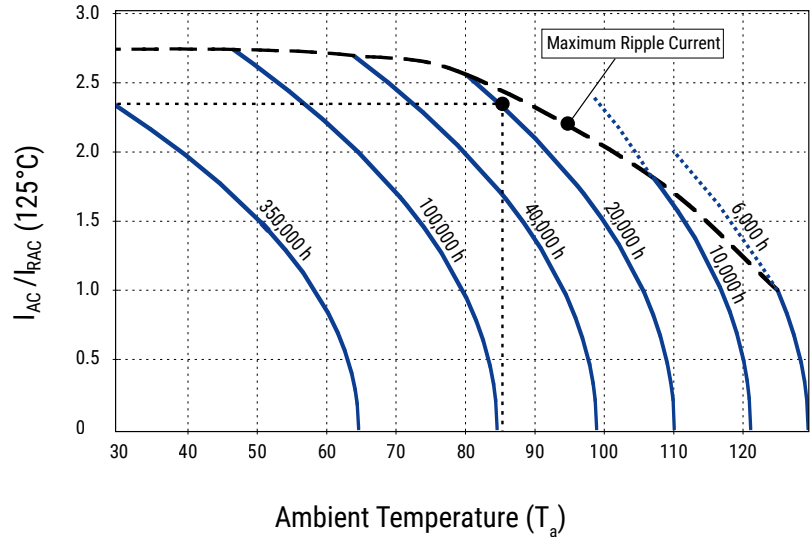

Operational Life PEG124 (+105°C)

Operational life (L_{op}) at ambient temperature T_a and ripple current I_{AC} .

Diagram valid for 20 mm case size.

Operational life,

16 mm case size: 0.67 x diagram value

13 mm case size: 0.44 x diagram value

10 mm case size: 0.37 x diagram value

Example:

Article: PEG124RL3150Q (20 x 46 mm)

Ambient temperature (T_a): +79°C

Ripple current, at 10 kHz (I_{AC}): 2.7 A

I_{RAC} (105°C ≥ 5 kHz) = 1.10 A (from data table)

→ I_{AC}/I_{RAC} (+105°C) = 2.45

Operational life: interpolation between the

L_{op} -curves → $L_{op} \sim 40 \text{ kh}$ (blue curves)

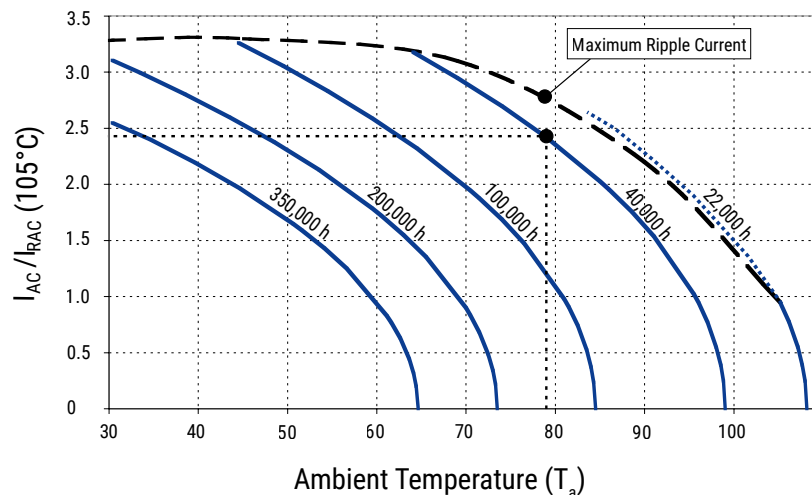

Marking



Construction

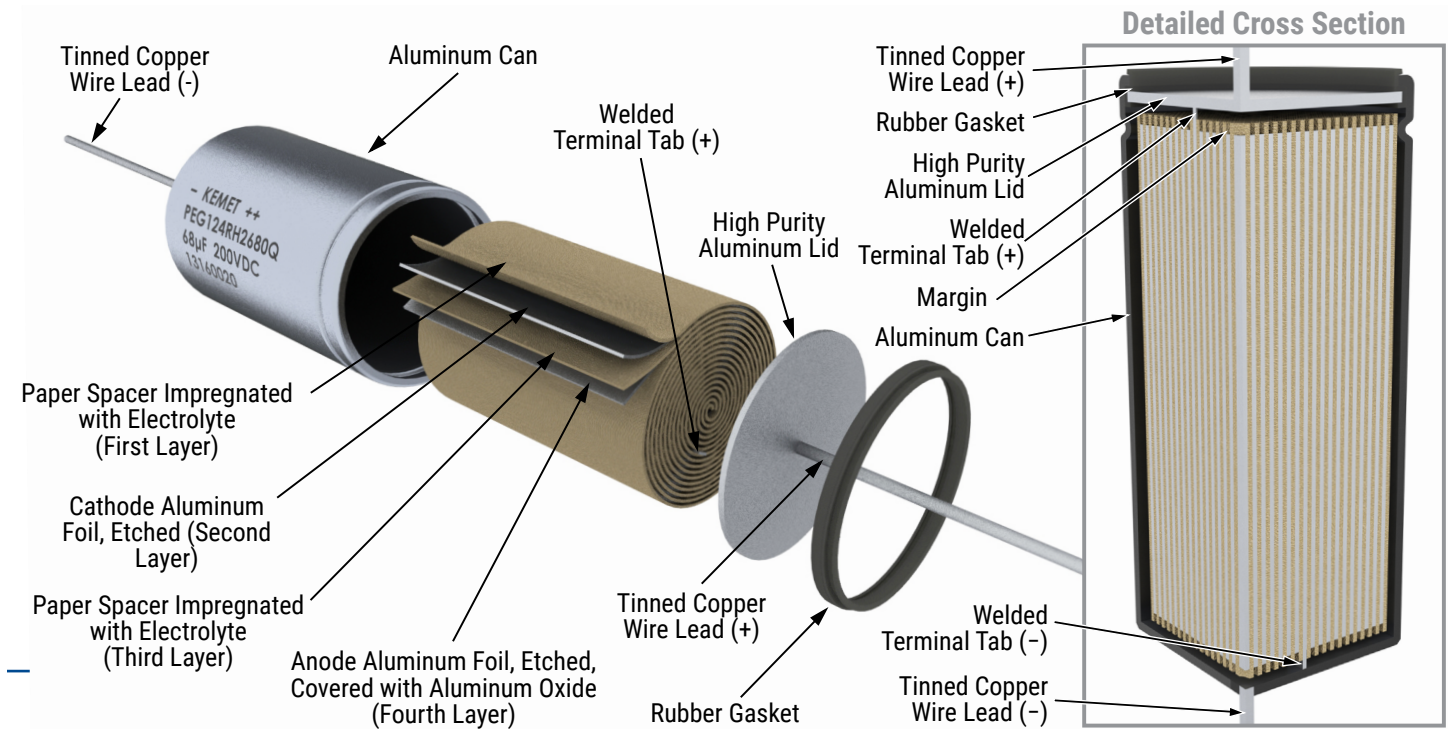

Construction Data

The manufacturing process begins with the anode foil being electrochemically etched to increase the surface area and then “formed” to produce the aluminum oxide layer. Both the anode and cathode foils are then interleaved with absorbent paper and wound into a cylinder. During the winding process, aluminum tabs are attached to each foil to provide the electrical contact.

The winding is assembled to the capacitor Al-can and to the Al-lid. The can is filled with electrolyte and the winding is impregnated during a vacuum treatment. The capacitor is sealed. Throughout the process, all materials inside the housing must be maintained at the highest purity and be compatible with the electrolyte.

Each capacitor is aged and tested before being packed. The purpose of aging is to repair any damage in the oxide layer and thus reduce the leakage current to a very low level. Aging is carried out at elevated temperature and is accomplished by applying voltage to the device while carefully controlling the supply current. The process takes between 2 and 20 hours, depending on voltage rating.

Damage to the oxide layer can occur due to a variety of reasons:

- Slitting of the anode foil after forming
- Attaching the tabs to the anode foil
- Minor mechanical damage caused during winding

The following tests are applied for each individual capacitor.

Electrical:

- Leakage current
- Capacitance
- ESR
- Tan Delta

Mechanical/Visual:

- Pull strength test of wire terminals
- Print detail
- Box labels
- Packaging, including packed quantity

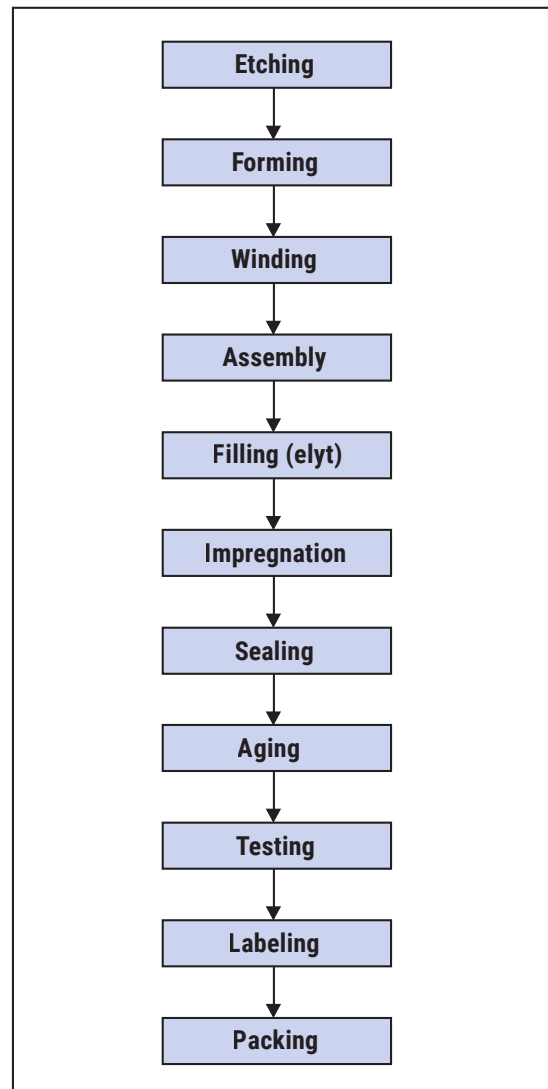
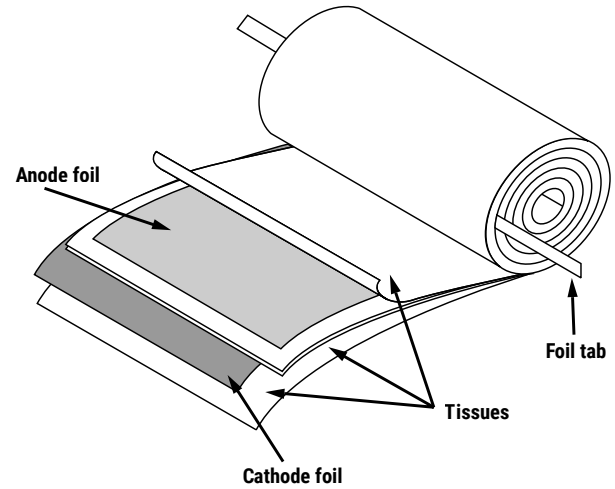

KEMET Electronics Corporation Sales Offices

For a complete list of our global sales offices, please visit <https://www.yageogroup.com/SalesResources/SalesOffices>

Disclaimer

YAGEO Corporation and its affiliates do not recommend the use of commercial or automotive grade products for high reliability applications or manned space flight.

All product specifications, statements, information and data (collectively, the "Information") in this datasheet are subject to change. The customer is responsible for checking and verifying the extent to which the Information contained in this publication is applicable to an order at the time the order is placed. All Information given herein is believed to be accurate and reliable, but it is presented without guarantee, warranty, or responsibility of any kind, expressed or implied.

Statements of suitability for certain applications are based on KEMET Electronics Corporation's ("KEMET") knowledge of typical operating conditions for such applications, but are not intended to constitute – and KEMET specifically disclaims – any warranty concerning suitability for a specific customer application or use. The Information is intended for use only by customers who have the requisite experience and capability to determine the correct products for their application. Any technical advice inferred from this Information or otherwise provided by KEMET with reference to the use of KEMET's products is given gratis, and KEMET assumes no obligation or liability for the advice given or results obtained.

Although KEMET designs and manufactures its products to the most stringent quality and safety standards, given the current state of the art, isolated component failures may still occur. Accordingly, customer applications which require a high degree of reliability or safety should employ suitable designs or other safeguards (such as installation of protective circuitry or redundancies) in order to ensure that the failure of an electrical component does not result in a risk of personal injury or property damage.

Although all product-related warnings, cautions and notes must be observed, the customer should not assume that all safety measures are indicated or that other measures may not be required.

KEMET requires its products to be packaged and shipped on pallets. This is because KEMET's products are specifically designed to be packed onto pallets during shipment. If for any reason, the products are removed from pallets by the shipping party and shipped to the end customer, then additional external protection is required. In this instance, an external box with two carton layers and an upwards orientation sticker must be used by the shipping party, with the empty space filled with filling material, and afterwards sealing the box. If this packing and packaging guideline is not followed by the shipping party, the shipping party, and not KEMET, will be held responsible for any packaging, packing and/or product damages upon delivery of the products to the end customer. KEMET hereby disclaims any liability for damages to the products or otherwise that have been, or threaten to be, inflicted, result from or are in any way related to the packaging, packing or damage by the shipping party in contravention of the packing and packaging guidelines herein.

KEMET is a registered trademark of KEMET Electronics Corporation.