

Overview

KEMET's M3 Medical Grade series provides a broad offering of surface mount multilayer ceramic capacitors (MLCCs) for high reliability medical applications, including implantable devices, that require long term life and performance. By utilizing robust designs, along with strict process and material control, this series provides a high reliability solution necessary for a wide variety of critical medical applications. Each lot is traceable down to raw materials and undergoes enhanced in-process and end-of-line testing including lot acceptance. KEMET's M3 Medical Grade series provides a baseline specification, which can be adapted to customer specific requirements for critical medical applications.

KEMET's M3 Medical Grade series is available in COG, X7R, and X5R dielectrics from EIA 0402 to 1210 case sizes with capacitance values ranging from 0.5 pF to 5.6 μ F. This series is available in voltage ratings up to 200 V, and is available in Sn, SnPb, and Au termination options.

The M3 series is available to customers willing to partner with KEMET to align application and performance requirements. For more information, please contact your local Sales Representative.

Benefits

- Custom testing and screening available upon request
- Enhanced designs
- Lot traceability down to raw materials
- 100% voltage conditioning
- End of Line Screening
- Lot acceptance testing data provided
- COG, X7R, and X5R dielectrics
- Capacitance offerings ranging from 0.5 pF up to 5.6 μ F
- EIA 0402 – 1210 case sizes
- DC voltage ratings of 6.3 V, 10 V, 16 V, 25 V, 50 V, 100 V, and 200 V
- Sn, SnPb, Au termination options
- Available capacitance tolerances of ± 0.10 pF, ± 0.25 pF, ± 0.5 pF, $\pm 1\%$, $\pm 2\%$, $\pm 5\%$, $\pm 10\%$, and $\pm 20\%$
- Low ESR and Low ESL



Applications

Typical Applications May Include:

- Cardiac pacemakers
- Neuromodulation devices
- Implantable cardioverter-defibrillator (ICD)
- Heart pumps

Ordering Information

C	0603	T	473	K	5	R	A	C	M003	-
Series	Case Size (L" x W")	Specification/ Series	Capacitance Code (pF)	Capacitance Tolerance	Rated Voltage (V)	Dielectric	Subclass Designation	Termination Finish	Medical C-Spec	Packaging (Suffix/ C-Spec)
C	0402 0603 0805 1206 1210	T	Two single digits and number of zeros. Use 9 for 1.0 - 9.9 pF Example: 2.2 pF = 229	B = ± 0.1 pF C = ± 0.25 pF D = ± 0.5 pF F = $\pm 1\%$ G = $\pm 2\%$ J = $\pm 5\%$ K = $\pm 10\%$ M = $\pm 20\%$	9 = 6.3 8 = 10 4 = 16 3 = 25 5 = 50 1 = 100 2 = 200	G = C0G R = X7R P = X5R	A = N/A	C = 100% matte Sn L = SnPb (5% Pb minimum) G = Gold (Au) 100 μ in minimum	M003 - Medical Grade	See "Packaging C-Spec Ordering Options Table" below

Packaging C-Spec Ordering Options Table

Packaging Type ¹	Packaging/Grade Ordering Code (C-Spec)
Standard Packaging (7" Tape & Reel)	Not required (blank)
Waffle Tray	7292

¹ Default packaging with no Packaging C-Spec is "7" Tape & Reel"

¹ See Tape & Reel Packaging information section of the datasheet for additional details.

Environmental Compliance

Lead (Pb)-free, RoHS, and REACH compliant if ordered with tin (Sn) or gold (Au) termination finish.

Dimensions – Millimeters (Inches)

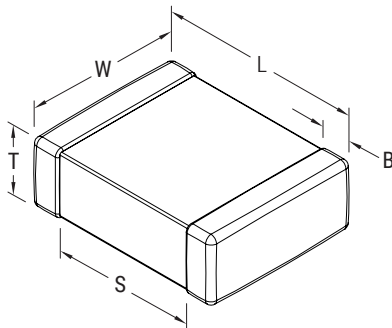

EIA Size Code	Metric Size Code	L Length	W Width	T Thickness	B Bandwidth	S Separation Minimum	Mounting Technique
0402	1005	1.00 (0.040) ±0.05 (0.002)	0.50 (0.020) ±0.05 (0.002)	See Table 2 for Thickness	0.30 (0.012) ±0.10 (0.004)	0.30 (0.012)	Solder Reflow Only
0603	1608	1.60 (0.063) ±0.15 (0.006)	0.80 (0.032) ±0.15 (0.006)		0.35 (0.014) ±0.15 (0.006)	0.50 (0.020)	Solder Wave or Solder Reflow
0805	2012	2.00 (0.079) ±0.20 (0.008)	1.25 (0.049) ±0.20 (0.008)		0.50 (0.02) ±0.25 (0.010)	0.70 (0.028)	
1206	3216	3.20 (0.126) ±0.20 (0.008)	1.60 (0.063) ±0.20 (0.008)		0.50 (0.02) ±0.25 (0.010)	1.50 (0.060)	Solder Reflow Only
1210	3225	3.20 (0.126) ±0.20 (0.008)	2.50 (0.098) ±0.20 (0.008)		0.50 (0.02) ±0.25 (0.010)	1.50 (0.060)	

Electrical Parameters/Characteristics

Item	Parameters/Characteristics
Operating temperature range	C0G/X7R: -55°C to +125°C X5R: -55°C to +85°C
Capacitance change with reference to +25°C and 0 VDC applied (TCC)	C0G: ±30 PPM/°C X5R/X7R: ±15%
Aging rate (maximum % capacitance loss/decade hour)	C0G: 0% X7R: 3% X5R: 5%
¹ Dielectric Withstanding Voltage (DWV)	250% of rated voltage (5 ±1 seconds and charge/discharge not exceeding 50 mA)
² Dissipation Factor (DF) Maximum Limit at 25°C	C0G: 0.1% X5R/X7R: See Tables 1A and 1B
³ Insulation Resistance (IR) Minimum Limit at 25°C	C0G: 1,000 • MΩ - μF or 100 GΩ X5R/X7R: See Tables 1C and 1D (Y)

¹ DWV is the voltage a capacitor can withstand (survive) for a short period of time. It exceeds the nominal and continuous working voltage of the capacitor.

² Capacitance and dissipation factor (DF) measured under the following conditions:

1 MHz ±100 kHz and 1.0 ±0.2 V_{rms} V if capacitance ≤ 1,000 pF

1 kHz ±50 Hz and 1.0 ±0.2 V_{rms} if capacitance > 1,000 pF

³ To obtain IR limit, divide MΩ - μF value by the capacitance and compare to GΩ limit. Select the lower of the two limits.

Note: When measuring capacitance it is important to ensure the set voltage level is held constant. The HP4284 and Agilent E4980 have a feature known as Automatic Level Control (ALC). The ALC feature should be switched to "ON."

Table 1A - Dissipation Factor Limit Table X7R

Rate DC Voltage	Dissipation Factor
< 16	5.0%
16/25	3.5%
> 25	2.5%

Table 1B - Dissipation Factor Limit Table X5R

Rate DC Voltage	Capacitance	Dissipation Factor
< 25	< 0.56 μ F	5.0%
	\geq 0.56 μ F	10.0%
25	All	3.5%
> 25	All	2.5%

Table 1C - Insulation Resistance Limit Table X7R

EIA Case Size	1,000 megohm microfarads or 100 G Ω	500 megohm microfarads or 10 G Ω
0402	< 0.012 μ F	\geq 0.012 μ F
0603	< 0.047 μ F	\geq 0.047 μ F
0805	< 0.15 μ F	\geq 0.15 μ F
1206	< 0.47 μ F	\geq 0.47 μ F
1210	< 0.39 μ F	\geq 0.39 μ F

Table 1D - Insulation Resistance Limit Table X5R

EIA Case Size	1,000 megohm microfarads or 100 G Ω	500 megohm microfarads or 10 G Ω	100 megohm microfarads
0402	< 0.012 μ F	\geq 0.012 μ F < 1.0 μ F	N/A
0603	< 0.047 μ F	\geq 0.047 μ F < 1.0 μ F	N/A
0805	< 0.15 μ F	\geq 0.15 μ F < 1.0 μ F	\geq 1.0 μ F
1206	< 0.47 μ F	\geq 0.47 μ F < 1.0 μ F	\geq 1.0 μ F
1210	< 0.39 μ F	\geq 0.39 μ F < 1.0 μ F	\geq 1.0 μ F

Table 2A – COG Product Ordering Codes and Ratings cont.

Cap	Cap Code	Case Size		0402					0603					0805					1206					1210								
		Voltage Code		8	4	3	5	1	8	4	3	5	1	2	8	4	3	5	1	2	8	4	3	5	1	2	8	4	3	5	1	2
		Rated Voltage (VDC)		10	16	25	50	100	10	16	25	50	100	200	10	16	25	50	100	200	10	16	25	50	100	200	10	16	25	50	100	200
		Capacitance Tolerance		Product Availability and Chip Thickness Codes See Table 2 for Chip Thickness Dimensions																												
180 pF	181	F	G	J	K	M	BB	BB	BB	BB	BB	CB	CB	CB	CB	CB	DC	DC	DC	DC	DC	EB	EB	EB	EB	EB	FB	FB	FB	FB	FB	FB
200 pF	201	F	G	J	K	M	BB	BB	BB	BB	BB	CB	CB	CB	CB	CB	DC	DC	DC	DC	DC	EB	EB	EB	EB	EB	FB	FB	FB	FB	FB	FB
220 pF	221	F	G	J	K	M	BB	BB	BB	BB	BB	CB	CB	CB	CB	CB	DC	DC	DC	DC	DC	EB	EB	EB	EB	EB	FB	FB	FB	FB	FB	FB
240 pF	241	F	G	J	K	M	BB	BB	BB	BB	BB	CB	CB	CB	CB	CB	DC	DC	DC	DC	DC	EB	EB	EB	EB	EB	FB	FB	FB	FB	FB	FB
270 pF	271	F	G	J	K	M	BB	BB	BB	BB	BB	CB	CB	CB	CB	CB	DC	DC	DC	DC	DC	EB	EB	EB	EB	EB	FB	FB	FB	FB	FB	FB
300 pF	301	F	G	J	K	M	BB	BB	BB	BB	BB	CB	CB	CB	CB	CB	DC	DC	DC	DC	DC	EB	EB	EB	EB	EB	FB	FB	FB	FB	FB	FB
330 pF	331	F	G	J	K	M	BB	BB	BB	BB	BB	CB	CB	CB	CB	CB	DC	DC	DC	DC	DC	EB	EB	EB	EB	EB	FB	FB	FB	FB	FB	FB
360 pF	361	F	G	J	K	M	BB	BB	BB	BB	BB	CB	CB	CB	CB	CB	DC	DC	DC	DC	DC	EB	EB	EB	EB	EB	FB	FB	FB	FB	FB	FB
390 pF	391	F	G	J	K	M	BB	BB	BB	BB	BB	CB	CB	CB	CB	CB	DC	DC	DC	DC	DC	EB	EB	EB	EB	EB	FB	FB	FB	FB	FB	FB
430 pF	431	F	G	J	K	M	BB	BB	BB	BB	BB	CB	CB	CB	CB	CB	DC	DC	DC	DC	DC	EB	EB	EB	EB	EB	FB	FB	FB	FB	FB	FB
470 pF	471	F	G	J	K	M	BB	BB	BB	BB	BB	CB	CB	CB	CB	CB	DC	DC	DC	DC	DC	EB	EB	EB	EB	EB	FB	FB	FB	FB	FB	FB
510 pF	511	F	G	J	K	M	BB	BB	BB	BB	BB	CB	CB	CB	CB	CB	DC	DC	DC	DC	DC	EB	EB	EB	EB	EB	FB	FB	FB	FB	FB	FB
560 pF	561	F	G	J	K	M	BB	BB	BB	BB	BB	CB	CB	CB	CB	CB	DC	DC	DC	DC	DC	EB	EB	EB	EB	EB	FB	FB	FB	FB	FB	FB
620 pF	621	F	G	J	K	M	BB	BB	BB	BB	BB	CB	CB	CB	CB	CB	DC	DC	DC	DC	DC	EB	EB	EB	EB	EB	FB	FB	FB	FB	FB	FB
680 pF	681	F	G	J	K	M	BB	BB	BB	BB	BB	CB	CB	CB	CB	CB	DC	DC	DC	DC	DC	EB	EB	EB	EB	EB	FB	FB	FB	FB	FB	FB
750 pF	751	F	G	J	K	M	BB	BB	BB	BB	BB	CB	CB	CB	CB	CB	DC	DC	DC	DC	DC	EB	EB	EB	EB	EB	FB	FB	FB	FB	FB	FB
820 pF	821	F	G	J	K	M	BB	BB	BB	BB	BB	CB	CB	CB	CB	CB	DC	DC	DC	DC	DC	EB	EB	EB	EB	EB	FB	FB	FB	FB	FB	FB
910 pF	911	F	G	J	K	M	BB	BB	BB	BB	BB	CB	CB	CB	CB	CB	DC	DC	DC	DC	DC	EB	EB	EB	EB	EB	FB	FB	FB	FB	FB	FB
1,000 pF	102	F	G	J	K	M	BB	BB	BB	BB	BB	CB	CB	CB	CB	CB	DC	DC	DC	DC	DC	EB	EB	EB	EB	EB	FB	FB	FB	FB	FB	FB
1,100 pF	112	F	G	J	K	M						CB	CB	CB	CB	CB	DC	DC	DC	DC	DC	EB	EB	EB	EB	EB	FB	FB	FB	FB	FB	FB
1,200 pF	122	F	G	J	K	M						CB	CB	CB	CB	CB	DC	DC	DC	DC	DC	EB	EB	EB	EB	EB	FB	FB	FB	FB	FB	FB
1,300 pF	132	F	G	J	K	M						CB	CB	CB	CB	CB	DC	DC	DC	DC	DC	EC	EC	EC	EC	EC	FC	FC	FC	FC	FC	FC
1,500 pF	152	F	G	J	K	M						CB	CB	CB	CB	CB	DC	DC	DC	DC	DC	EC	EC	EC	EC	EC	FE	FE	FE	FE	FE	FE
1,600 pF	162	F	G	J	K	M						CB	CB	CB	CB	CB	DC	DC	DC	DC	DC	ED	ED	ED	ED	ED	FE	FE	FE	FE	FE	FE
1,800 pF	182	F	G	J	K	M						CB	CB	CB	CB	CB	DC	DC	DC	DC	DC	ED	ED	ED	ED	ED	FE	FE	FE	FE	FE	FE
2,000 pF	202	F	G	J	K	M						CB	CB	CB	CB	CB	DC	DC	DC	DC	DC	EB	EB	EB	EB	EB	FE	FE	FE	FE	FE	FE
2,200 pF	222	F	G	J	K	M						CB	CB	CB	CB	CB	DC	DC	DC	DC	DC	EB	EB	EB	EB	EB	FG	FG	FG	FG	FG	FG
2,400 pF	242	F	G	J	K	M						CB	CB	CB	CB	CB	DC	DC	DC	DC	DC	EB	EB	EB	EB	EB	FC	FC	FC	FC	FC	FC
2,700 pF	272	F	G	J	K	M						CB	CB	CB	CB	CB	DC	DC	DC	DC	DC	EB	EB	EB	EB	EB	FC	FC	FC	FC	FC	FC
3,000 pF	302	F	G	J	K	M						CB	CB	CB	CB	CB	DC	DC	DC	DC	DC	EB	EB	EB	EB	EB	FF	FF	FF	FF	FF	FF
3,300 pF	332	F	G	J	K	M						CB	CB	CB	CB	CB	DC	DC	DC	DC	DC	EB	EB	EB	EB	EB	FB	FB	FB	FB	FB	FB
3,600 pF	362	F	G	J	K	M						CB	CB	CB	CB	CB	DD	DD	DD	DD	DD	EB	EB	EB	EB	EB	FB	FB	FB	FB	FB	FB
3,900 pF	392	F	G	J	K	M						CB	CB	CB	CB	CB	DD	DD	DD	DD	DD	EB	EB	EB	EB	EB	FB	FB	FB	FB	FB	FB
4,300 pF	432	F	G	J	K	M						CB	CB	CB	CB	CB	DD	DD	DD	DD	DD	EB	EB	EB	EB	EB	FB	FB	FB	FB	FB	FB
4,700 pF	472	F	G	J	K	M						CB	CB	CB	CB	CB	DD	DD	DD	DD	DD	EB	EB	EB	EB	EB	FB	FB	FB	FB	FB	FB
5,100 pF	512	F	G	J	K	M						CB	CB	CB	CB	CB	DD	DD	DD	DD	DD	EB	EB	EB	EB	EB	FB	FB	FB	FB	FB	FB
5,600 pF	562	F	G	J	K	M						CB	CB	CB	CB	CB	DD	DD	DD	DD	DD	EB	EB	EB	EB	EB	FB	FB	FB	FB	FB	FB
6,200 pF	622	F	G	J	K	M						CB	CB	CB	CB	CB	DG	DG	DG	DG	DG	EB	EB	EB	EB	EB	FB	FB	FB	FB	FB	FB
6,800 pF	682	F	G	J	K	M						CB	CB	CB	CB	CB	DG	DG	DG	DG	DG	EB	EB	EB	EB	EB	FB	FB	FB	FB	FB	FB
7,500 pF	752	F	G	J	K	M											DG	DG	DG	DG	DG	EB	EB	EB	EB	EB	FB	FB	FB	FB	FB	FB
8,200 pF	822	F	G	J	K	M											DG	DG	DG	DG	DG	EC	EC	EC	EC	EC	FB	FB	FB	FB	FB	FB
9,100 pF	912	F	G	J	K	M											DD	DD	DD	DD	DD	EC	EC	EC	EC	EC	FB	FB	FB	FB	FB	FB
10,000 pF	103	F	G	J	K	M											DD	DD	DD	DD	DD	EC	EC	EC	EC	EC	FB	FB	FB	FB	FB	FB
12,000 pF	123	F	G	J	K	M											DC	DC	DC			ED	ED	ED	ED	ED	FB	FB	FB	FB	FB	FB
15,000 pF	153	F	G	J	K	M											DD	DD	DD			EF	EF	EF	EF	EF	FC	FC	FC	FC	FC	FC
18,000 pF	183	F	G	J	K	M																EH	EH	EH	EH	EH	FC	FC	FC	FC	FC	FC
22,000 pF	223	F	G	J	K	M																EC	EC	EC	EC	EC	FF	FF	FF	FF	FF	FF
27,000 pF	273	F	G	J	K	M																EE	EE	EE	EE	EE	FG	FG	FG	FG	FG	FG
33,000 pF	333	F	G	J	K	M																EB	EB	EB			FH	FH	FH	FH	FH	FH
39,000 pF	393	F	G	J	K	M																					FE	FE	FE	FE	FE	FE
47,000 pF	473	F	G	J	K	M																					FE	FE	FE	FE	FE	FE
56,000 pF	563	F	G	J	K	M																					FB	FB	FB			
Capacitance	Cap Code	Rated Voltage (VDC)		10	16	25	50	100	10	16	25	50	100	200	10	16	25	50	100	200	10	16	25	50	100	200	10	16	25	50	100	200
		Voltage Code		8	4	3	5	1	8	4	3	5	1	2	8	4	3	5	1	2	8	4	3	5	1	2	8	4	3	5	1	2
		Case Size		0402					0603					0805					1206					1210								

Table 2B – X7R Product Ordering Codes and Ratings cont.

Cap	Cap Code	Case Size		0402					0603					0805					1206						1210												
		Voltage Code		9	8	4	3	5	9	8	4	3	5	1	9	8	4	3	5	1	9	8	4	3	5	1	2	9	8	4	3	5	1	2			
		Rated Voltage (VDC)		6.3	10	16	25	50	6.3	10	16	25	50	100	6.3	10	16	25	50	100	6.3	10	16	25	50	100	200	6.3	10	16	25	50	100	200			
		Capacitance Tolerance		Product Availability and Chip Thickness Codes See Table 2 for Chip Thickness Dimensions																																	
330 pF	331			F	G	J	K	M	BB	BB	BB	BB	BB	CB	CB	CB	CB	CB	CB	DC	DC	DC	DC	DC	DC	EB	EB	EB	EB	EB	EB	FB	FB	FB	FB	FB	FB
390 pF	391			F	G	J	K	M	BB	BB	BB	BB	BB	CB	CB	CB	CB	CB	CB	DC	DC	DC	DC	DC	DC	EB	EB	EB	EB	EB	EB	FB	FB	FB	FB	FB	FB
470 pF	471			F	G	J	K	M	BB	BB	BB	BB	BB	CB	CB	CB	CB	CB	CB	DC	DC	DC	DC	DC	DC	EB	EB	EB	EB	EB	EB	FB	FB	FB	FB	FB	FB
560 pF	561			F	G	J	K	M	BB	BB	BB	BB	BB	CB	CB	CB	CB	CB	CB	DC	DC	DC	DC	DC	DC	EB	EB	EB	EB	EB	EB	FB	FB	FB	FB	FB	FB
680 pF	681			F	G	J	K	M	BB	BB	BB	BB	BB	CB	CB	CB	CB	CB	CB	DC	DC	DC	DC	DC	DC	EB	EB	EB	EB	EB	EB	FB	FB	FB	FB	FB	FB
820 pF	821			F	G	J	K	M	BB	BB	BB	BB	BB	CB	CB	CB	CB	CB	CB	DC	DC	DC	DC	DC	DC	EB	EB	EB	EB	EB	EB	FB	FB	FB	FB	FB	FB
1,000 pF	102			F	G	J	K	M	BB	BB	BB	BB	BB	CB	CB	CB	CB	CB	CB	DC	DC	DC	DC	DC	DC	EB	EB	EB	EB	EB	EB	FB	FB	FB	FB	FB	FB
1,200 pF	122			F	G	J	K	M	BB	BB	BB	BB	BB	CB	CB	CB	CB	CB	CB	DC	DC	DC	DC	DC	DC	EB	EB	EB	EB	EB	EB	FB	FB	FB	FB	FB	FB
1,500 pF	152			F	G	J	K	M	BB	BB	BB	BB	BB	CB	CB	CB	CB	CB	CB	DC	DC	DC	DC	DC	DC	EC	EC	EC	EC	EC	EC	FE	FE	FE	FE	FE	FE
1,800 pF	182			F	G	J	K	M	BB	BB	BB	BB	BB	CB	CB	CB	CB	CB	CB	DC	DC	DC	DC	DC	DC	ED	ED	ED	ED	ED	ED	FE	FE	FE	FE	FE	FE
2,200 pF	222			F	G	J	K	M	BB	BB	BB	BB	BB	CB	CB	CB	CB	CB	CB	DC	DC	DC	DC	DC	DC	EB	EB	EB	EB	EB	EB	FG	FG	FG	FG	FG	FG
2,700 pF	272			F	G	J	K	M	BB	BB	BB	BB	BB	CB	CB	CB	CB	CB	CB	DC	DC	DC	DC	DC	DC	EB	EB	EB	EB	EB	EB	FC	FC	FC	FC	FC	FC
3,300 pF	332			F	G	J	K	M	BB	BB	BB	BB	BB	CB	CB	CB	CB	CB	CB	DC	DC	DC	DC	DC	DC	EB	EB	EB	EB	EB	EB	FF	FF	FF	FF	FF	FF
3,900 pF	392			F	G	J	K	M	BB	BB	BB	BB	BB	CB	CB	CB	CB	CB	CB	DD	DD	DD	DD	DD	DD	EB	EB	EB	EB	EB	EB	FB	FB	FB	FB	FB	FB
4,700 pF	472			F	G	J	K	M	BB	BB	BB	BB	BB	CB	CB	CB	CB	CB	CB	DD	DD	DD	DD	DD	DD	EB	EB	EB	EB	EB	EB	FB	FB	FB	FB	FB	FB
5,600 pF	562			F	G	J	K	M	BB	BB	BB	BB	BB	CB	CB	CB	CB	CB	CB	DD	DD	DD	DD	DD	DD	EB	EB	EB	EB	EB	EB	FB	FB	FB	FB	FB	FB
6,800 pF	682			F	G	J	K	M	BB	BB	BB	BB	BB	CB	CB	CB	CB	CB	CB	DG	DG	DG	DG	DG	DG	EB	EB	EB	EB	EB	EB	FB	FB	FB	FB	FB	FB
8,200 pF	822			F	G	J	K	M	BB	BB	BB	BB	BB	CB	CB	CB	CB	CB	CB	DD	DD	DD	DD	DD	DD	EC	EC	EC	EC	EC	EC	FB	FB	FB	FB	FB	FB
10,000 pF	103								BB	BB	BB	BB	BB	CB	CB	CB	CB	CB	CB	DD	DD	DD	DD	DD	DD	EC	EC	EC	EC	EC	EC	FB	FB	FB	FB	FB	FB
12,000 pF	123								BB	BB	BB	BB	BB	CB	CB	CB	CB	CB	CB	DG	DG	DG	DG	DG	DG	ED	ED	ED	ED	ED	ED	FB	FB	FB	FB	FB	FB
15,000 pF	153								BB	BB	BB	BB	BB	CB	CB	CB	CB	CB	CB	DG	DG	DG	DG	DG	DG	EF	EF	EF	EF	EF	EF	FC	FC	FC	FC	FC	FC
18,000 pF	183								BB	BB	BB	BB	BB	CB	CB	CB	CB	CB	CB	DG	DG	DG	DG	DG	DG	EH	EH	EH	EH	EH	EH	FC	FC	FC	FC	FC	FC
22,000 pF	223								BB	BB	BB	BB	BB	CB	CB	CB	CB	CB	CB	DG	DG	DG	DG	DG	DG	EH	EH	EH	EH	EH	EH	FF	FF	FF	FF	FF	FF
27,000 pF	273								BB	BB				CB	CB	CB	CB	CB	CB	DG	DG	DG	DG	DG	DG	EB	EB	EB	EB	EB	EB	FG	FG	FG	FG	FG	FG
33,000 pF	333								BB	BB				CB	CB	CB	CB	CB	CB	DG	DG	DG	DG	DG	DG	EB	EB	EB	EB	EB	EB	FH	FH	FH	FH	FH	FH
39,000 pF	393								BB	BB				CB	CB	CB	CB	CB	CB	DG	DG	DG	DG	DG	DG	EB	EB	EB	EB	EB	EB	FE	FE	FE	FE	FE	FE
47,000 pF	473								BB	BB				CB	CB	CB	CB	CB	CB	DG	DG	DG	DG	DG	DG	EB	EB	EB	EB	EB	EB	FE	FE	FE	FE	FE	FE
56,000 pF	563													CB	CB	CB	CB	CB	CB	DG	DG	DG	DG	DG	DG	EC	EC	EC	EC	EC	EC	FE	FE	FE	FE	FE	FE
68,000 pF	683													CB	CB	CB	CB	CB	CB	DD	DD	DD	DD	DD	DD	EC	EC	EC	EC	EC	EC	FE	FE	FE	FE	FE	FE
82,000 pF	823													CB	CB	CB	CB	CB	CB	DD	DD	DD	DD	DD	DD	ED	ED	ED	ED	ED	ED	FE	FE	FE	FE	FE	FE
0.1 uF	104													CB	CB	CB	CB	CB	CB	DG	DG	DG	DG	DG	DG	ED	ED	ED	ED	ED	ED	FE	FE	FE	FE	FE	FE
0.12 uF	124													CB	CB	CB	CB	CB	CB	DG	DG	DG	DG	DG	DG	EM	EM	EM	EM	EM	EM	FE	FE	FE	FE	FE	FE
0.15 uF	154													CB	CB	CB	CB	CB	CB	DG	DG	DG	DG	DG	DG	EM	EM	EM	EM	EM	EM	FF	FF	FF	FF	FF	FF
0.18 uF	184													CB	CB					DD	DD	DD	DD	DD	DD	EC	EC	EC	EC	EC	EC	FF	FF	FF	FF	FF	FF
0.22 uF	224													CB	CB					DD	DD	DD	DD	DD	DD	ED	ED	ED	ED	ED	ED	FC	FC	FC	FC	FC	FC
0.27 uF	274																			DD	DD	DD	DD	DD	DD	EM	EM	EM	EM	EM	EM	FC	FC	FC	FC	FC	FC
0.33 uF	334																			DD	DD	DD	DD	DD	DD	EM	EM	EM	EM	EM	EM	FE	FE	FE	FE	FE	FE
0.39 uF	394																			DE	DE	DE	DE	DE	DE	EC	EC	EC	EC	EC	EC	FG	FG	FG	FG	FG	FG
0.47 uF	474																			DE	DE	DE	DE	DE	DE	EC	EC	EC	EC	EC	EC	FG	FG	FG	FG	FG	FG
0.56 uF	564																			DG	DG	DG	DG			EC	EC	EC	EC			FH	FH	FH	FH	FH	FH
0.68 uF	684																			DG	DG					ED	ED	ED	ED			FH	FH	FH	FH	FH	FH
0.82 uF	824																			DG	DG					ED	ED	ED	ED			FE	FE	FE	FE	FE	FE
1 uF	105																			DG	DG					ED	ED	ED	ED			FE	FE	FE	FE	FE	FE
1.2 uF	125																									EH	EH	EH	EH			FG	FG	FG	FG		
1.5 uF	155																									EH	EH	EH	EH			FG	FG	FG	FG		
1.8 uF	185																									EF	EF					FG	FG	FG	FG		
2.2 uF	225																									EF	EF					FG	FG	FG	FG		
2.7 uF	275																															FG	FG				
3.3 uF	335																															FM	FM				

Table 3 – Chip Thickness/Tape & Reel Packaging Quantities

Thickness Code	Case Size ¹	Thickness ± Range (mm)	Paper Quantity		Plastic Quantity	
			7" Reel	13" Reel	7" Reel	13" Reel
BB	0402	0.50 ± 0.05	10,000	50,000	0	0
CB	0603	0.80 ± 0.07	4,000	10,000	0	0
DC	0805	0.78 ± 0.10	4,000	10,000	0	0
DD	0805	0.90 ± 0.10	4,000	10,000	0	0
DE	0805	1.00 ± 0.10	0	0	2,500	10,000
DG	0805	1.25 ± 0.15	0	0	2,500	10,000
EB	1206	0.78 ± 0.10	4,000	10,000	4,000	10,000
EC	1206	0.90 ± 0.10	0	0	4,000	10,000
ED	1206	1.00 ± 0.10	0	0	2,500	10,000
EE	1206	1.10 ± 0.10	0	0	2,500	10,000
EF	1206	1.20 ± 0.15	0	0	2,500	10,000
EH	1206	1.60 ± 0.20	0	0	2,000	8,000
EM	1206	1.25 ± 0.15	0	0	2,500	10,000
FB	1210	0.78 ± 0.10	0	0	4,000	10,000
FC	1210	0.90 ± 0.10	0	0	4,000	10,000
FE	1210	1.00 ± 0.10	0	0	2,500	10,000
FF	1210	1.10 ± 0.10	0	0	2,500	10,000
FG	1210	1.25 ± 0.15	0	0	2,500	10,000
FH	1210	1.55 ± 0.15	0	0	2,000	8,000
FM	1210	1.70 ± 0.20	0	0	2,000	8,000
Thickness Code	Case Size ¹	Thickness ± Range (mm)	7" Reel	13" Reel	7" Reel	13" Reel
			Paper Quantity ¹		Plastic Quantity	

Table 4 – Chip Capacitor Land Pattern Design Recommendations per IPC-7351

EIA Size Code	Metric Size Code	Density Level A: Maximum (Most) Land Protrusion (mm)					Density Level B: Median (Nominal) Land Protrusion (mm)					Density Level C: Minimum (Least) Land Protrusion (mm)				
		C	Y	X	V1	V2	C	Y	X	V1	V2	C	Y	X	V1	V2
0402	1005	0.50	0.72	0.72	2.20	1.20	0.45	0.62	0.62	1.90	1.00	0.40	0.52	0.52	1.60	0.80
0603	1608	0.90	1.15	1.10	4.00	2.10	0.80	0.95	1.00	3.10	1.50	0.60	0.75	0.90	2.40	1.20
0805	2012	1.00	1.35	1.55	4.40	2.60	0.90	1.15	1.45	3.50	2.00	0.75	0.95	1.35	2.80	1.70
1206	3216	1.60	1.35	1.90	5.60	2.90	1.50	1.15	1.80	4.70	2.30	1.40	0.95	1.70	4.00	2.00
1210	3225	1.60	1.35	2.80	5.65	3.80	1.50	1.15	2.70	4.70	3.20	1.40	0.95	2.60	4.00	2.90

Density Level A: For low-density product applications. Recommended for wave solder applications and provides a wider process window for reflow solder processes. KEMET only recommends wave soldering of EIA 0603, 0805 and 1206 case sizes.

Density Level B: For products with a moderate level of component density. Provides a robust solder attachment condition for reflow solder processes.

Density Level C: For high component density product applications. Before adapting the minimum land pattern variations the user should perform qualification testing based on the conditions outlined in IPC Standard 7351 (IPC-7351).

Image below based on Density Level B for an EIA 1210 case size.

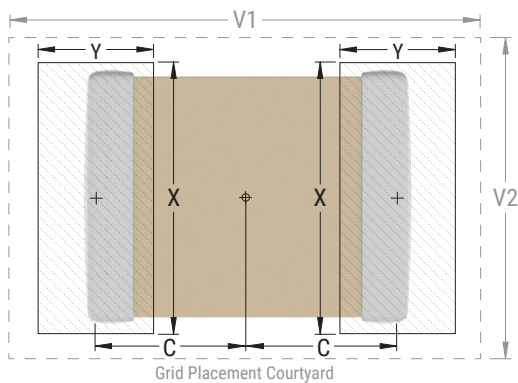

Soldering Process

Recommended Soldering Technique:

- Solder wave or solder reflow for EIA case sizes 0603, 0805 and 1206
- All other EIA case sizes are limited to solder reflow only

Recommended Reflow Soldering Profile:

KEMET's families of surface mount multilayer ceramic capacitors (SMD MLCCs) are compatible with wave (single or dual), convection, IR or vapor phase reflow techniques. Preheating of these components is recommended to avoid extreme thermal stress. KEMET's recommended profile conditions for convection and IR reflow reflect the profile conditions of the IPC/J-STD-020 standard for moisture sensitivity testing. These devices can safely withstand a maximum of three reflow passes at these conditions.

Profile Feature	Termination Finish	
	SnPb	100% Matte Sn
Preheat/Soak		
Temperature Minimum (T_{Smin})	100°C	150°C
Temperature Maximum (T_{Smax})	150°C	200°C
Time (t_s) from T_{Smin} to T_{Smax}	60 – 120 seconds	60 – 120 seconds
Ramp-Up Rate (T_L to T_p)	3°C/second maximum	3°C/second maximum
Liquidous Temperature (T_L)	183°C	217°C
Time Above Liquidous (t_L)	60 – 150 seconds	60 – 150 seconds
Peak Temperature (T_p)	235°C	260°C
Time Within 5°C of Maximum Peak Temperature (t_p)	20 seconds maximum	30 seconds maximum
Ramp-Down Rate (T_p to T_L)	6°C/second maximum	6°C/second maximum
Time 25°C to Peak Temperature	6 minutes maximum	8 minutes maximum

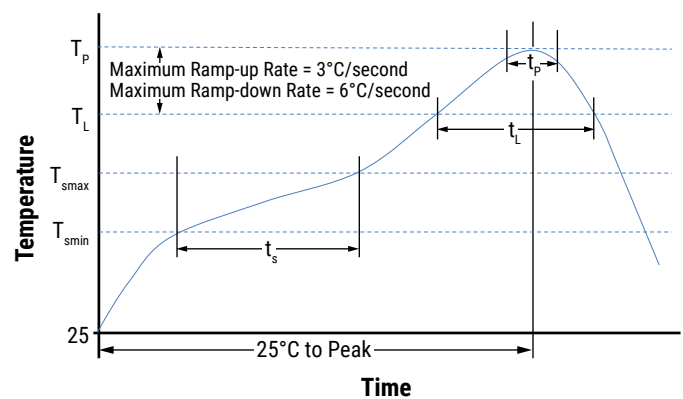

Note: All temperatures refer to the center of the package, measured on the capacitor body surface that is facing up during assembly reflow.

Table 5 – Performance & Reliability: Test Methods and Conditions

Stress	Reference	Test or Inspection Method		
		Case Size	Force	Duration
Terminal Strength	AEC-Q200-006	< 0805	5 N (0.51 kg)	60 seconds
		≥ 0805	10 N (1.02 kg)	
Board Flex	AEC-Q200-005	COG – 3.0 mm (minimum) X7R/X5R – 2.0 mm (minimum)		
Resistance to Soldering Heat	MIL-STD-202 Method 210	Test Condition J, 1 heat cycle		
Solderability	J-STD-002	Magnification 50X. Conditions:		
		a) Method B, 4 hours at 155°C, dry heat at 235°C		
Temperature Cycling	JESD22 Method JA-104	1,000 cycles (-55°C to +125°C), measurement at 24 hours, ±4 hours after test conclusion		
Biased Humidity	MIL-STD-202 Method 103	Load Humidity: 1,000 hours 85°C/85% RH and 200 VDC maximum. Add 100 KΩ resistor. Measurement at 24 hours, ±4 hours after test conclusion		
High Temperature Life	MIL-STD-202 Method 108/EIA -198	COG/X7R: 1,000 hours at 125°C with 2.0 X rated voltage applied		
		X5R: 1,000 hours at 85°C with 2.0 X rated voltage applied		

Storage & Handling

Ceramic chip capacitors should be stored in normal working environments. While the chips themselves are quite robust in other environments, solderability will be degraded by exposure to high temperatures, high humidity, corrosive atmospheres, and long term storage. In addition, packaging materials will be degraded by high temperature – reels may soften or warp and tape peel force may increase. KEMET recommends that maximum storage temperature not exceed 40°C and maximum storage humidity not exceed 70% relative humidity. Temperature fluctuations should be minimized to avoid condensation on the parts. Atmospheres should be free of chlorine and sulfur bearing compounds. For optimized solderability, chip stock should be used promptly, preferably within 1.5 years upon receipt.

Construction

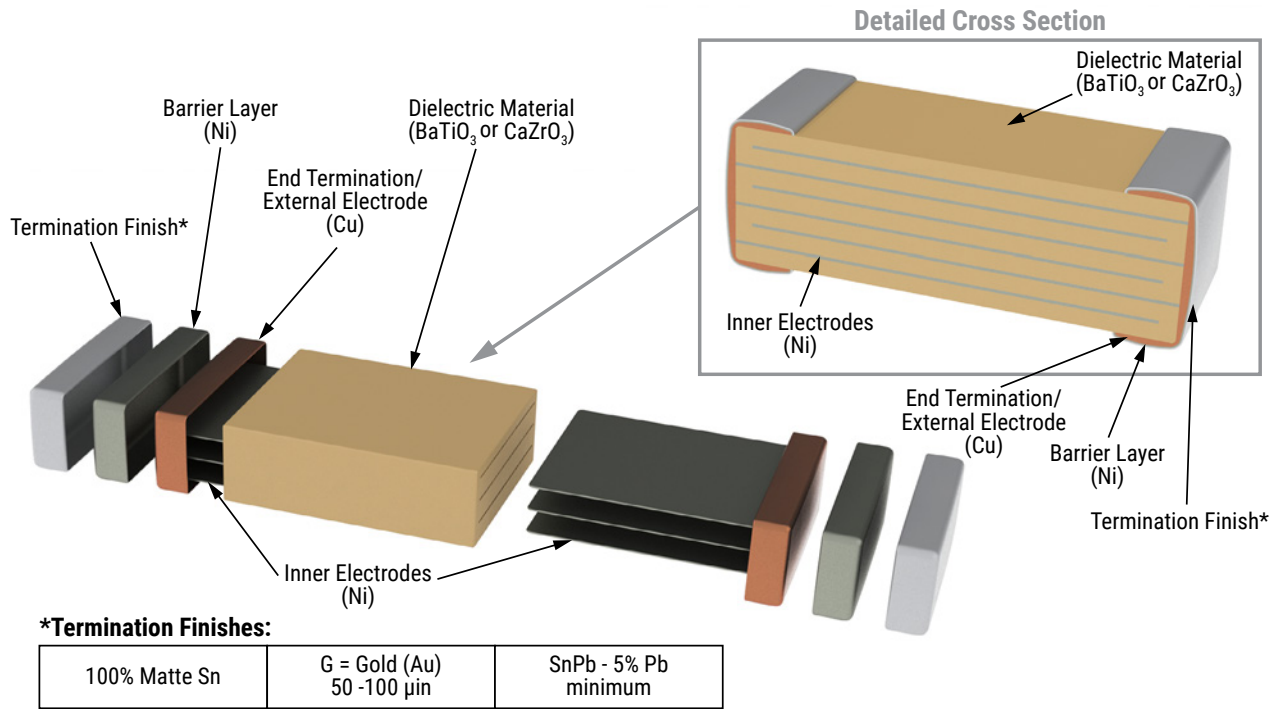

Tape & Reel Packaging Information

KEMET offers multilayer ceramic chip capacitors packaged in 8, 12 and 16 mm tape on 7" and 13" reels in accordance with EIA Standard 481. This packaging system is compatible with all tape-fed automatic pick and place systems. See Table 2 for details on reeling quantities for commercial chips.

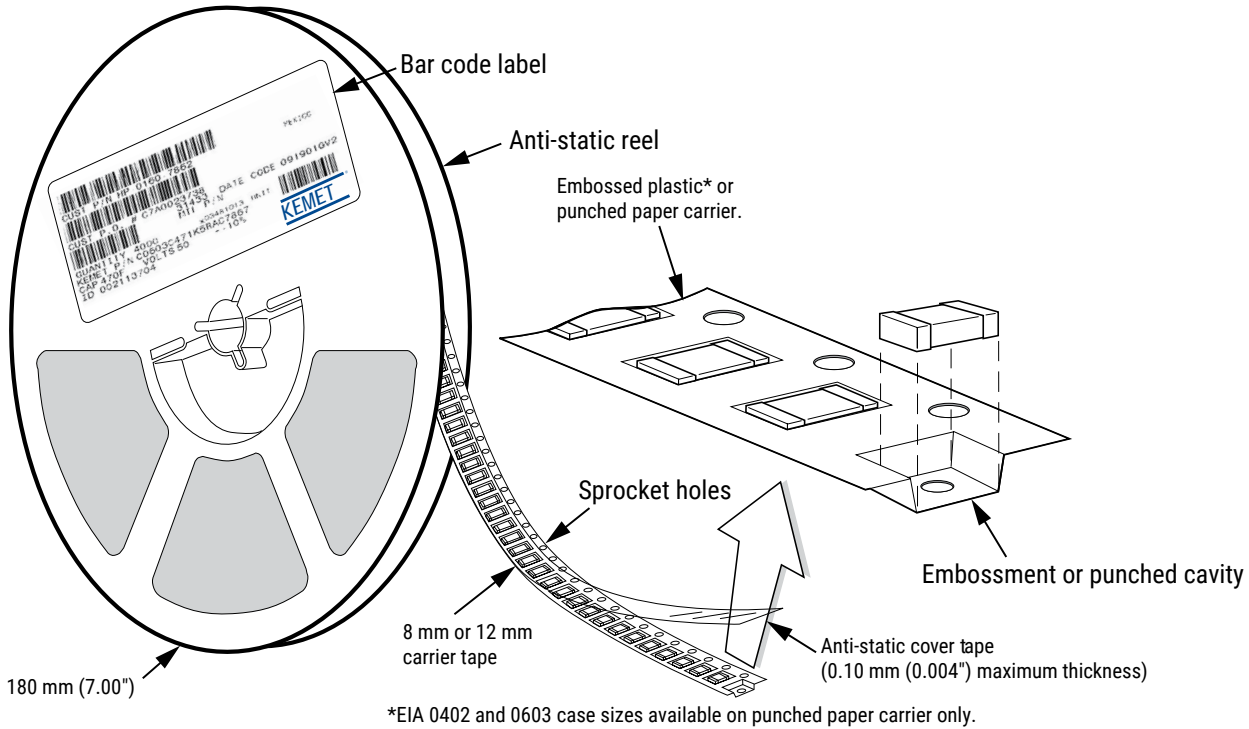

Table 6 – Carrier Tape Configuration, Embossed Plastic & Punched Paper (mm)

EIA Case Size	Tape Size (W)*	Embossed Plastic	Punched Paper
		7" Reel	7" Reel
		Pitch (P ₁)*	
0402	8		2
0603	8		4
0805	8	4	4
1206 – 1210	8	4	4

*Refer to Figures 1 and 2 for W and P₁ carrier tape reference locations.

*Refer to Tables 2A, 2B and 2C for tolerance specifications.

Figure 1 – Embossed (Plastic) Carrier Tape Dimensions

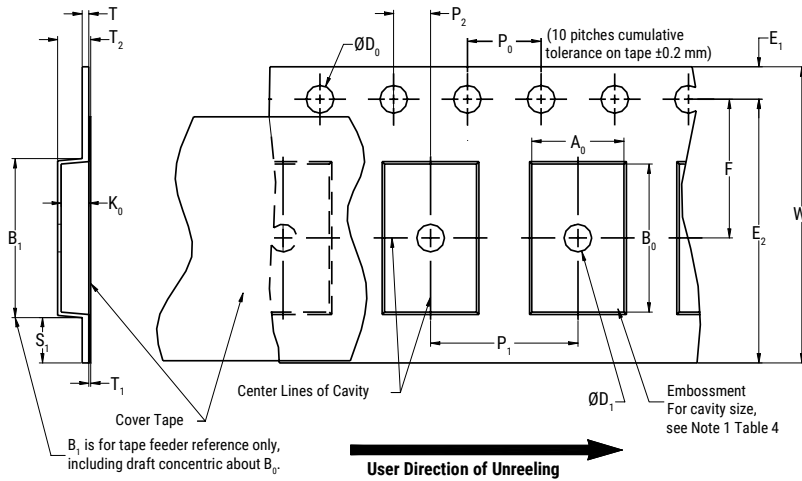

Table 7 – Embossed (Plastic) Carrier Tape Dimensions

Metric will govern

Constant Dimensions – Millimeters (Inches)									
Tape Size	D ₀	D ₁ Minimum Note 1	E ₁	P ₀	P ₂	R Reference Note 2	S1 Minimum Note 3	T Maximum	T ₁ Maximum
8 mm	1.5 +0.10/-0.0	1.0 (0.039)	1.75 ±0.10	4.0 ±0.10	2.0 ±0.05	25.0 (0.984)	0.600 (0.024)	0.600 (0.024)	0.100 (0.004)
12 mm	(0.059 +0.004/-0.0)	1.5 (0.059)	(0.069 ±0.004)	(0.157 ±0.004)	(0.079 ±0.002)	30 (1.181)			
Variable Dimensions – Millimeters (Inches)									
Tape Size	Pitch	B ₁ Maximum Note 4	E ₂ Minimum	F	P ₁	T ₂ Maximum	W Maximum	A ₀ , B ₀ & K ₀	
8 mm	Single (4 mm)	4.35 (0.171)	6.25 (0.246)	3.5 ±0.05 (0.138 ±0.002)	4.0 ±0.10 (0.157 ±0.004)	2.5 (0.098)	8.3 (0.327)	Note 5	
12 mm	Single (4 mm) and Double (8 mm)	8.2 (0.323)	10.25 (0.404)	5.5 ±0.05 (0.217 ±0.002)	8.0 ±0.10 (0.315 ±0.004)	4.6 (0.181)	12.3 (0.484)		

- The embossment hole location shall be measured from the sprocket hole controlling the location of the embossment. Dimensions of the embossment location and the hole location shall be applied independently of each other.
- The tape with or without components shall pass around R without damage (see Figure 6.)
- If S₁ < 1.0 mm, there may not be enough area for a cover tape to be properly applied (see EIA Standard 481, paragraph 4.3, section b.)
- B₁ dimension is a reference dimension for tape feeder clearance only.
- The cavity defined by A₀, B₀ and K₀ shall surround the component with sufficient clearance that:
 - the component does not protrude above the top surface of the carrier tape.
 - the component can be removed from the cavity in a vertical direction without mechanical restriction, after the top cover tape has been removed.
 - rotation of the component is limited to 20° maximum for 8 and 12 mm tapes and 10° maximum for 16 mm tapes (see Figure 3.)
 - lateral movement of the component is restricted to 0.5 mm maximum for 8 and 12 mm wide tape and to 1.0 mm maximum for 16 mm tape (see Figure 4.)
 - see addendum in EIA Document 481 for standards relating to more precise taping requirements.

Table 8 – Punched (Paper) Carrier Tape Dimensions

Metric will govern

Constant Dimensions – Millimeters (Inches)							
Tape Size	D_0	E_1	P_0	P_2	T_1 Maximum	G Minimum	R Reference Note 2
8 mm	$1.5 + 0.10/-0.0$ ($0.059 + 0.004/-0.0$)	1.75 ± 0.10 (0.069 ± 0.004)	4.0 ± 0.10 (0.157 ± 0.004)	2.0 ± 0.05 (0.079 ± 0.002)	0.100 (0.004)	0.75 (0.030)	25.0 (0.984)
Variable Dimensions – Millimeters (Inches)							
Tape Size	Pitch	E_2 Minimum	F	P_1	T Maximum	W Maximum	A_0 & B_0
8 mm	Half (2 mm)	6.25 (0.246)	3.5 ± 0.05 (0.138 ± 0.002)	2.0 ± 0.05 (0.079 ± 0.002)	1.1 (0.098)	8.3 (0.327)	Note 1
	Single (4 mm)			4.0 ± 0.10 (0.157 ± 0.004)		8.3 (0.327)	

1. The cavity defined by A_0 , B_0 and T , shall surround the component with sufficient clearance that:

(a) the component does not protrude above the top surface of the carrier tape.

(b) the component can be removed from the cavity in a vertical direction without mechanical restriction, after the top cover tape has been removed.

(c) rotation of the component is limited to 20° maximum (see Figure 3.)

(d) lateral movement of the component is restricted to 0.5 mm maximum (see Figure 4.)

(e) see addendum in EIA Document 481 for standards relating to more precise taping requirements.

2. The tape with or without components shall pass around R without damage (see Figure 6).

Packaging Information Performance Notes

1. **Cover Tape Break Force:** 1.0 kg minimum.

2. **Cover Tape Peel Strength:** The total peel strength of the cover tape from the carrier tape shall be:

Tape Width	Peel Strength
8 mm	0.1 to 1.0 newton (10 to 100 gf)
12 and 16 mm	0.1 to 1.3 newton (10 to 130 gf)

The direction of the pull shall be opposite the direction of the carrier tape travel. The pull angle of the carrier tape shall be 165° to 180° from the plane of the carrier tape. During peeling, the carrier and/or cover tape shall be pulled at a velocity of 300 ±10 mm/minute.

3. **Labeling:** Bar code labeling (standard or custom) shall be on the side of the reel opposite the sprocket holes. Refer to EIA Standards 556 and 624.

Figure 2 – Maximum Component Rotation

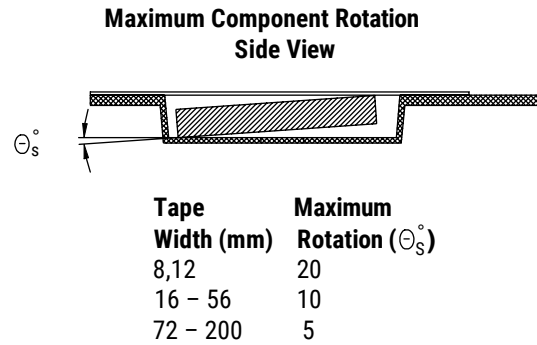
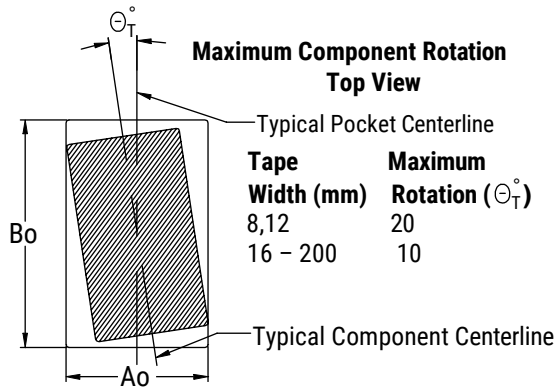

Figure 3 – Maximum Lateral Movement

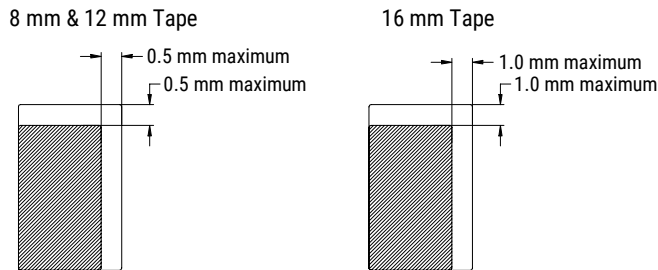

Figure 4 – Bending Radius

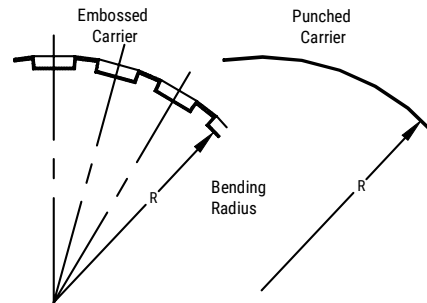
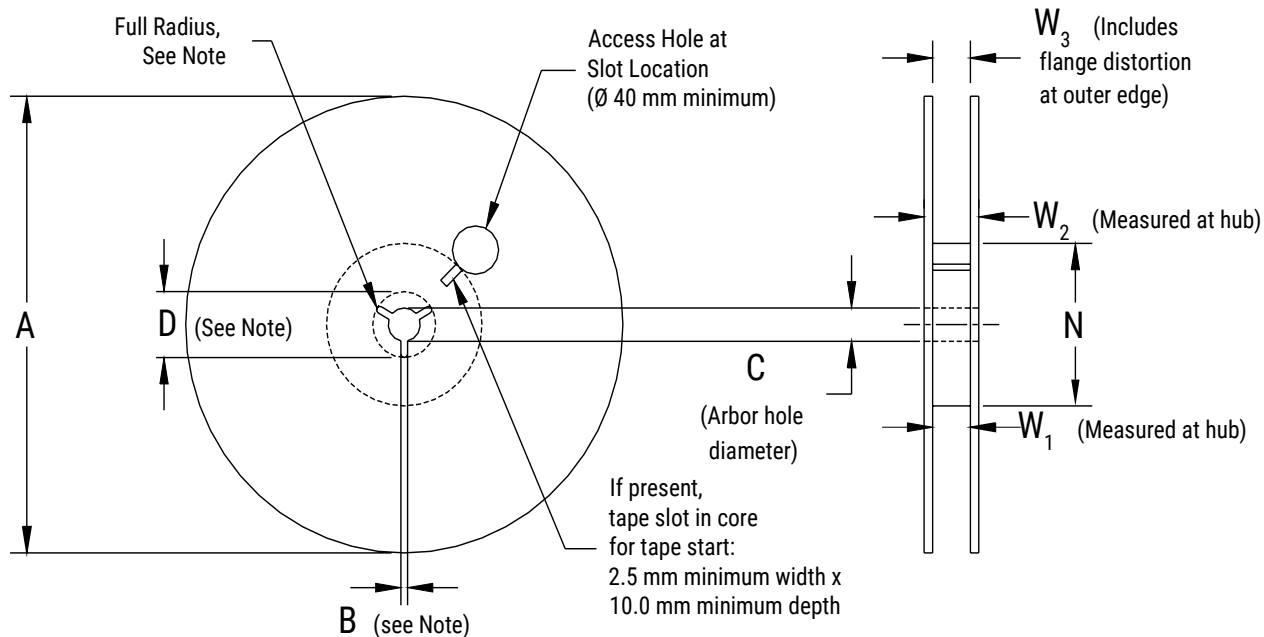

Figure 5 – Reel Dimensions



Note: Drive spokes optional; if used, dimensions B and D shall apply.

Table 9 – Reel Dimensions

Metric will govern

Constant Dimensions – Millimeters (Inches)				
Tape Size	A	B Minimum	C	D Minimum
8 mm	178 ± 0.20 (7.008 ± 0.008)	1.5 (0.059)	$13.0 + 0.5/-0.2$ (0.521 + 0.02/-0.008)	20.2 (0.795)
12 mm	330 ± 0.20 (13.000 ± 0.008)			
Variable Dimensions – Millimeters (Inches)				
Tape Size	N Minimum See Note 2, Tables 6 – 7	W_1	W_2 Maximum	W_3
8 mm	50 (1.969)	$8.4 + 1.5/-0.0$ (0.331 + 0.059/-0.0)	14.4 (0.567)	Shall accommodate tape width without interference
12 mm		$12.4 + 2.0/-0.0$ (0.488 + 0.078/-0.0)	18.4 (0.724)	

Figure 6 – Tape Leader & Trailer Dimensions



Figure 7 – Maximum Camber



Waffle Tray Packaging Information – 2" x 2" w/ Static Protection

Figure 8 – Waffle Tray Dimensions – Inches (Millimeters)

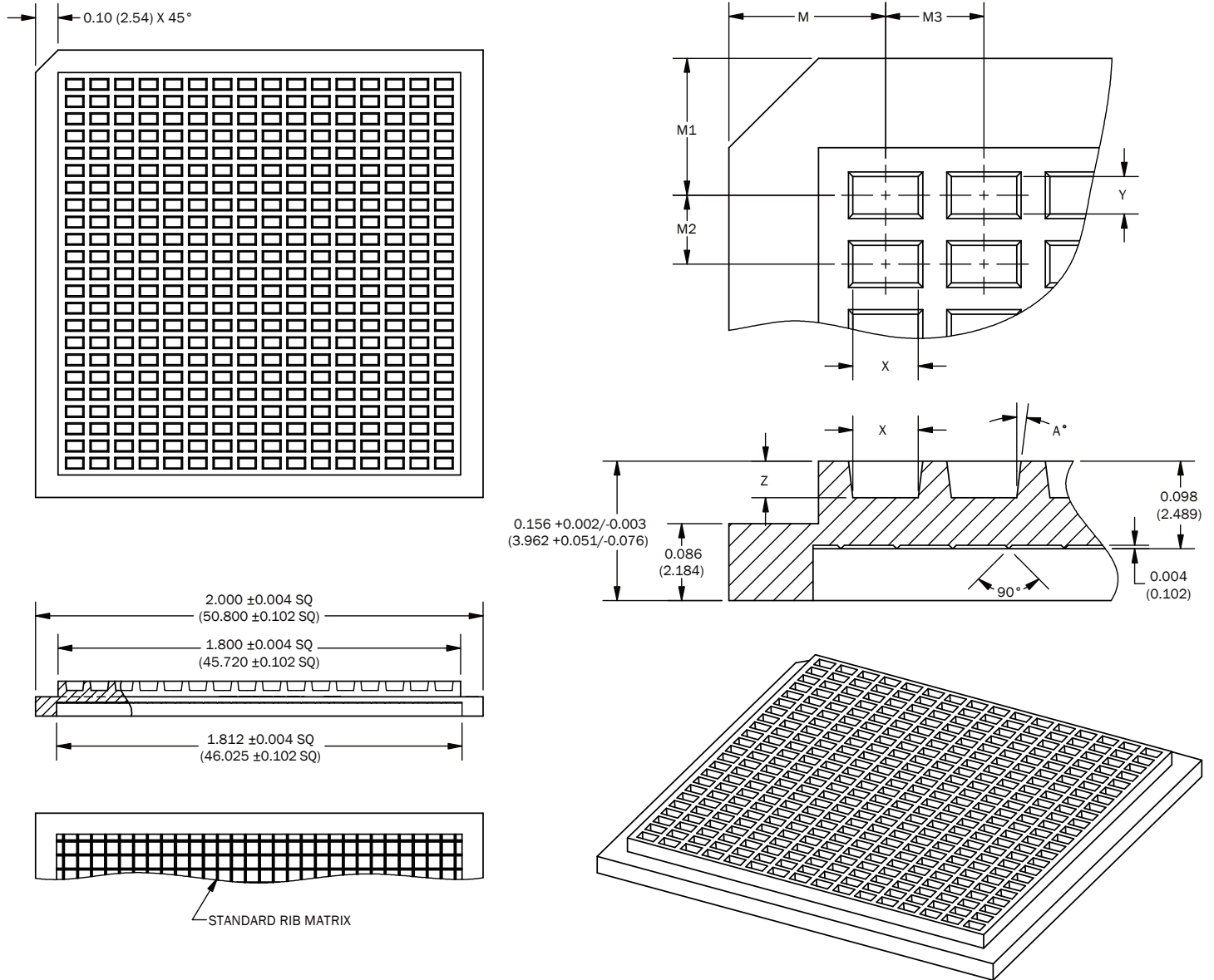

Table 10A – Waffle Tray Dimensions – Inches

Case Size		2" x 2" Waffle Tray Dimensions – Inches									Packaging Quantity (pcs/unit packaging)
		M	M1	M2	M3	X	Y	Z	A°	MATRIX	
EIA (in)	Metric (mm)	±0.003	±0.003	±0.002	±0.002	±0.002	±0.002	±0.003	± 1/2°	(X x Y)	
0402	1005	0.175	0.153	0.077	0.110	0.073	0.042	0.041	7	16 X 23	368
0603	1608	0.175	0.153	0.077	0.110	0.073	0.042	0.041	7	16 X 23	368
0805	2012	0.232	0.186	0.181	0.171	0.062	0.092	0.036	10	10 X 10	100
1206 ^{1,2}	3216	0.194	0.228	0.193	0.124	0.067	0.130	0.065	5	14 X 9	126
1206 ^{1,3}	3216	0.250	0.250	0.375	0.167	0.100	0.200	0.070	5	10 X 5	50
1210	3225	0.217	0.244	0.215	0.174	0.110	0.145	0.080	5	10 X 8	80

¹ Packaging of 1206 (3216 metric) case size capacitors is dependent upon the nominal chip thickness of the device. Contact KEMET Sales for Waffle Tray quantities for specified part number.

² Assigned to 1206 (3216 metric) case size capacitors with nominal thickness of $\leq 1.25\text{mm}$ (0.049 inches).

³ Assigned to 1206 (3216 metric) case size capacitors with nominal thickness of $> 1.25\text{mm}$ (0.049 inches).

Table 10B – Waffle Tray Dimensions – Millimeters

Case Size		2" x 2" Waffle Tray Dimensions – Millimeters									Packaging Quantity (pcs/unit packaging)
		M	M1	M2	M3	X	Y	Z	A°	MATRIX	
EIA (in)	Metric (mm)	±0.08	±0.08	±0.05	±0.05	±0.05	±0.05	±0.08	± 1/2°	(X x Y)	
0402	1005	4.45	3.89	1.96	2.79	1.85	1.07	1.04	7	16 X 23	368
0603	1608	4.45	3.89	1.96	2.79	1.85	1.07	1.04	7	16 X 23	368
0805	2012	5.89	4.72	4.60	4.34	1.57	2.34	0.91	10	10 X 10	100
1206 ^{1,2}	3216	4.93	5.79	4.90	3.15	1.70	3.30	1.65	5	14 X 9	126
1206 ^{1,3}	3216	6.35	6.35	9.53	4.24	2.54	5.08	1.78	5	10 X 5	50
1210	3225	5.51	6.20	5.46	4.42	2.79	3.68	2.03	5	10 X 8	80

¹ Packaging of 1206 (3216 metric) case size capacitors is dependent upon the nominal chip thickness of the device. Contact KEMET Sales for Waffle Tray quantities for specified part number.

² Assigned to 1206 (3216 metric) case size capacitors with nominal thickness of $\leq 1.25\text{mm}$ (0.049 inches).

³ Assigned to 1206 (3216 metric) case size capacitors with nominal thickness of $> 1.25\text{mm}$ (0.049 inches).

KEMET Electronics Corporation Sales Offices

For a complete list of our global sales offices, please visit www.kemet.com/sales.

Disclaimer

YAGEO Corporation and its affiliates do not recommend the use of commercial or automotive grade products for high reliability applications or manned space flight.

All product specifications, statements, information and data (collectively, the "Information") in this datasheet are subject to change. The customer is responsible for checking and verifying the extent to which the Information contained in this publication is applicable to an order at the time the order is placed. All Information given herein is believed to be accurate and reliable, but it is presented without guarantee, warranty, or responsibility of any kind, expressed or implied.

Statements of suitability for certain applications are based on KEMET Electronics Corporation's ("KEMET") knowledge of typical operating conditions for such applications, but are not intended to constitute – and KEMET specifically disclaims – any warranty concerning suitability for a specific customer application or use. The Information is intended for use only by customers who have the requisite experience and capability to determine the correct products for their application. Any technical advice inferred from this Information or otherwise provided by KEMET with reference to the use of KEMET's products is given gratis, and KEMET assumes no obligation or liability for the advice given or results obtained.

Although KEMET designs and manufactures its products to the most stringent quality and safety standards, given the current state of the art, isolated component failures may still occur. Accordingly, customer applications which require a high degree of reliability or safety should employ suitable designs or other safeguards (such as installation of protective circuitry or redundancies) in order to ensure that the failure of an electrical component does not result in a risk of personal injury or property damage.

Although all product-related warnings, cautions and notes must be observed, the customer should not assume that all safety measures are indicated or that other measures may not be required.

KEMET is a registered trademark of KEMET Electronics Corporation.