



Overview

YAGEO Group's SCE Series consists of ultra-high capacity Electric Double-Layer Capacitors (EDLCs) engineered for applications that demand extremely low internal resistance, large-scale energy storage, and high-current discharge. Designed to handle extreme power demands, this series provides a robust power bridge for heavy-duty industrial and automotive systems requiring instantaneous energy release.

Applications

Engineered for high-load systems such as Jump Starters, Server Back-up Power, and Microgrid Energy Storage infrastructure.

Benefits

- Massive Capacitance available from 220F up to 3000F at 2.7 VDC
- Ultra-Low ESR as low as 0.26 mΩ (DC)
- Low Leakage current ranging from 0.8 mA to 5.2 mA
- Extremely Large Current Capability up to 2275A
- Superior Power Density up to 7594 W/kg
- Maximum energy capacity up to 3.0375 W.h
- Stable performance maintained from from -40°C to +70°C.
- Humidity Proof tested at 90%~95% RH (240h)
- Vibration resistance 10 ~ 55Hz
- Extreme Longevity Rated for >500,000 cycles
- Robust Solid-state design: Maintenance-Free

Radial



Snap-in

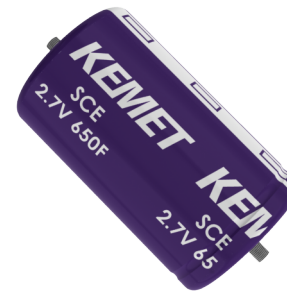

Part Number System

SCE	EQ	2206	Y	2R7	S	C000
Series Rated	Size Code	Capacitance Code (F)	Tolerance	Rated Voltage (VDC)	Termination Code	Electrical Parameters
Supercapacitor Low ESR Series	See Dimension Table	First three digits represent significant figures. Forth digit specifies number of zeros.	Y = -10/+30%	2R7 = 2.7	S = Axial	C000 = Standard

Dimensions – Millimeters

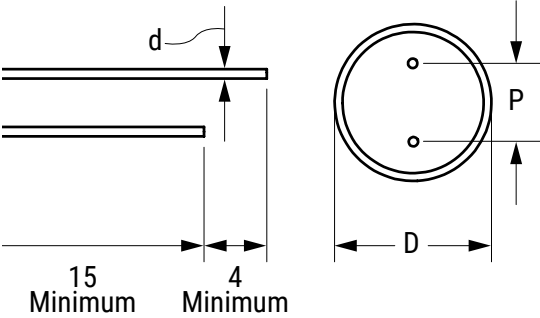

D		L		d		T	
Nominal	Tolerance	Nominal	Tolerance	Nominal	Tolerance	Nominal	Tolerance
35	±1.5	50	±2	26.6	±0.1	3.5	±0.5
35	±1.5	60	±2	26.6	±0.1	3.5	±0.5
35	±1.5	70	±2	26.6	±0.1	3.5	±0.5
35	±1.5	70	±2	26.6	±0.1	3.5	±0.5
35	±1.5	85	±2	26.6	±0.1	3.5	±0.5
35	±1.5	85	±2	26.6	±0.1	3.5	±0.5
35	±1.5	100	±2	26.6	±0.1	3.5	±0.5
35	±1.5	110	±2	26.6	±0.1	3.5	±0.5

Termination Tables

Termination Code	S
Diameter mm	
22	•
25	•
30	•
35	•

Mounting: These capacitors are designed to be mounted by their terminations a•one and may be used in any position.

Termination Code	Termination Style	LL
		Nominal
Standard Termination Option		
S	Three Column Solder	3.5
Dimensions in mm		

Mounting: These capacitors are designed to be mounted by their terminations alone and may be used in any position.

Environmental Compliance



All Part Numbers in this datasheet are Reach and RoHS compliant and Halogen-Free.

As an environmentally conscious company, KEMET is working continuously with improvements concerning the environmental effects of both our capacitors and their production.

In Europe (RoHS Directive) and in some other geographical areas such as China, legislation has been put in place to prevent the use of some hazardous materials, such as lead (Pb), in electronic equipment. All products in this catalog are produced to help our customers' obligations to guarantee their products and fulfill these legislative requirements. The only material of concern in our products has been lead (Pb), which has been removed from all designs to fulfill the requirement of containing less than 0.1% of lead in any homogeneous material.

KEMET will closely follow any changes in legislation world wide and makes any necessary changes in its products, whenever needed.

Some customer segments such as medical, military, and automotive electronics may still require the use of lead in electrode coatings. To clarify the situation and distinguish products from each other, a special symbol is used on the packaging labels for RoHS compatible capacitors.

Due to customer requirements, there may appear additional markings such as LF = Lead-free or LFW = Lead-free wire on the label.

Performance Characteristics

Item	Performance Characteristics	
Specifications	Working Voltage	2.7 VDC
	Surge Voltage	2.85 VDC
	Nominal Capacitance	300F ~ 3000F
	Capacitance Tolerance	-20% ~ +50%; -20% ~ +20%; -10% ~ +30%;
	Operation Temperature	-40°C~+70°C
Cycle life characteristics	Capacitors cycles between specified voltage and half rated voltage under constant current at +25°C (> 500,000 cycles)	
	Capacitance Change	≤ 30% of initial value
	Internal Resistance	≤ 2 times of specified value
	Appearance	No remarkable change
High temperature load life	Temperature	+70°C
	Voltage	Rated voltage
	Testing duration	1,000(+48)hrs
	Capacitance Change	≤ 30% of specified value
	Internal Resistance	≤ 2 times of specified value
	Appearance	No remarkable change
Temperature characteristics	Temperature	T±2°C (-40°C≤T≤+70°C)
	Storage duration	12hrs
	Non-loaded	-
	Capacitance Change	≤ 30% of initial value
	Internal Resistance	≤ 2 times of specified value
	Appearance	No remarkable change
Humidity characteristic	Voltage	Nominal voltage
	Relative humidity	90%~95%
	Testing duration	240hrs
	Temperature	40±2°C
	Capacitance Change	≤ 30% of specified value
	Internal Resistance	≤ 2 times of specified value
	Appearance	No remarkable change
Vibration resistance	Amplitude	1.5mm
	Frequency	10 ~ 55Hz
	Direction	X,Y,Z (2hrs)
	Duration of testing	6hrs
	Capacitance Change	≤ 30% of initial value
	Internal Resistance	≤ 2 times of specified value
	Appearance	No remarkable change

Test Method & Performance

Capacitance Test

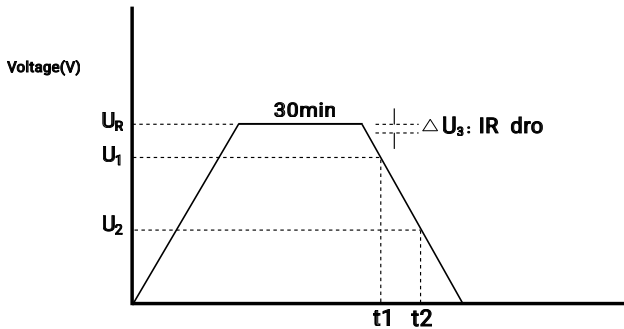

Capacitance calculation formula:

$$C = \frac{I \times (t_2 - t_1)}{U_1 - U_2}$$

- I: Discharge current $I = 4 \times C \times U_R$ (mA)
- U_1 : Initial voltage $U_1 = 0.8 \times U_R$ (V)
- U_2 : Test ended voltage $U_2 = 0.4 \times U_R$ (V)
- t_1 : Time corresponding to initial voltage (s);
- t_2 : Time corresponding to test finish voltage (s);

IEC ESR test

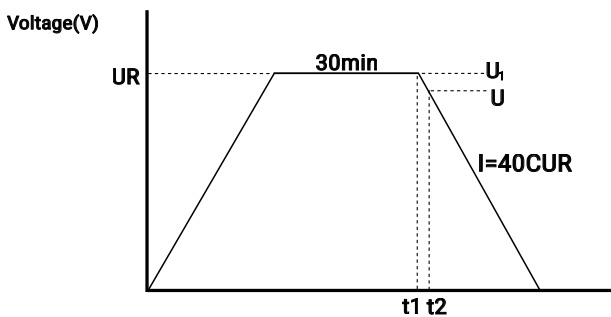

ESR Calculation formula:

$$ESR_{DC} = \frac{U_1 - U_2}{I}$$

- I: Discharge current $I = 40 \times C \times U_R$ (mA)
- U_1 : Initial voltage at discharge beginning;
- U_2 : Ended voltage after 10 msec's discharge;
- Δt : Time for discharge $\Delta t = (t_2 - t_1) = 10 \text{ msec}$

Test Method & Performance cont.

Capacity and ESRDC Test Method in Six Steps standard

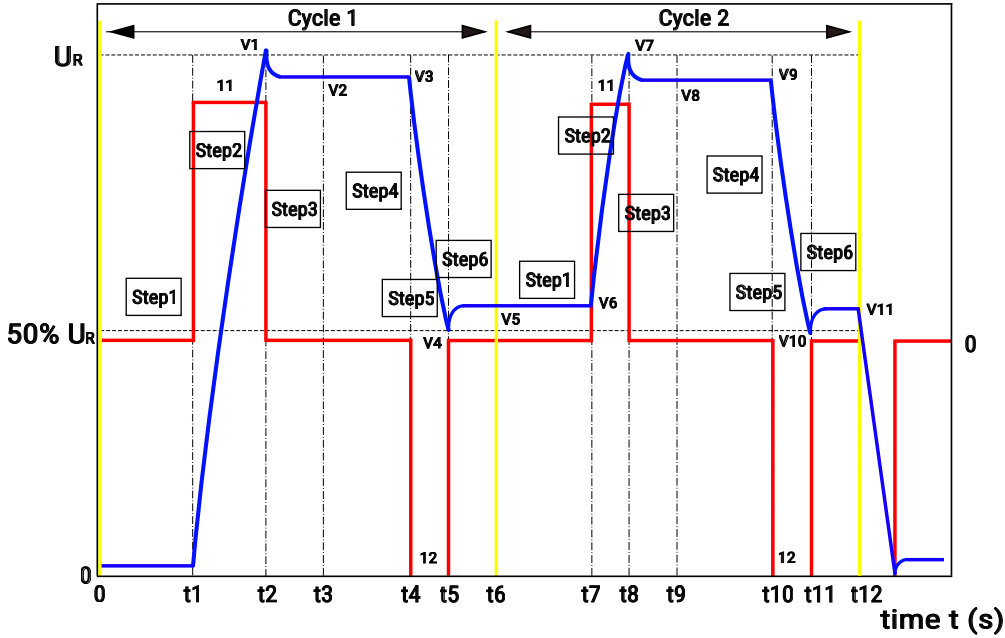

Discharge capacitance of the two cycle:

$$C_{dch1} = I_2 \times \frac{(t_5 - t_4)}{(V_3 - V_4)} \quad C_{dch2} = I_2 \times \frac{(t_{11} - t_{10})}{(V_9 - V_{10})}$$

Discharge DC internal resistance of two cycles:

$$C_{dch2} = I_2 \times \frac{(t_{11} - t_{10})}{(V_9 - V_{10})} \quad ESR_{dch2} = \frac{(V_{11} - V_{10})}{I_2}$$

Discharge capacitance:

$$ESR_{dch2} = \frac{(V_{11} - V_{10})}{I_2}$$

Discharge DCESR:

$$ESR_{dch} = \frac{(ESR_{dch1} + ESR_{dch2})}{2}$$

Note: $I_1 = I_2 = 75\text{mA/F}$, the rated capacitance in the chart means discharge capacitance, and DC ESR (ESRDC) means discharge DC resistance. A six-step ESRDC test method is illustrated to the right and carried out as follows:

1. Rest 10 seconds
2. Charge under constant current (I_1) to rated voltage (V_R)
3. Rest 5 seconds
4. Rest 10 seconds, record V_3 and t_4
5. Discharge under constant current (I_2) to half rated voltage, record I_2 , V_4 , and t_5
6. Rest 5 seconds, record V_5 and t_6 Repeat steps 1-6 recording I , V , and t accordingly, finally discharging to below 0.1V under constant current (I_2).

Test Method & Performance cont.

Maximum operating current:the maximum current when temperature rised 15°C

$$I_{MAX} = \sqrt{15 \times S / ESR_{DC}}$$

Maximum peak current:the maximum current which the capacitor discharges from UR to 1/2 UR in 1 second

$$I_{MAX} = 0.5 U_R / (R_{DC} + 1/C)$$

Leakage current:the current after72 hours constant voltage load in 25°C

Maximum storage energy:

$$E = 0.5CU_R^2$$

Power density:

$$Pd = (0.12 \times U_R^2 / ESR_{DC})/mass$$

Energy density:

$$Ed = (0.5CU_R^2)/(3600 \times mass)$$

Technical Information

Life Time

The basic end-of life failure mode for the EDLC is a decrease in capacitance and/or an increase in equivalent series resistance(ESR). Usually take the standard of capacitance decrease by 30% and/or ESR increase to 200% as the symbol of EDLC life end. Just the performance of EDLC will continue to decay during the application, but not to be scrapped. When its performance can not keep at the application level required, the super capacitor will be scrapped.

The EDLC's life mainly depends on working voltage and ambient temperature. If the capacitors are placed in high temperature or work at high voltage, their life time will be shortened. If the applied voltage is over rated voltage for long time, gas generation will occur inside the EDLC and may result in electrolyte leakage or rupture of safety vent. Increased ESR at higher temperature will lead to electrolyte decompose inside the EDLC and result in permanent degradation.

Reverse voltage

The positive and negative polarity of EDLC are similar in composition. So there's no real polarity for EDLC in theory. To keep consistency of manufacture and products, there's negative polarity sign on each capacitor. It is recommended to keep right polarity, though it will not cause disastrous failure when reverse charge. It will greatly shorten the life of EDLC when charge it in one polarity for long and then reverse charge.

Temperature Performance

EDLC normal working temperature is -40°C~+70°C. If the EDLC is applied in higher temperature than rated temperature, it will cause capacitance decrease quickly, ESR increase and decomposition of electrolyte, which will produce a large volume of gas, then lead to electrolyte leakage or rupture of safety vent. The higher the temperature and the longer the time, the performance of EDLC will be worse.

Generally, the ambient temperature raise by every 10°C, the life time of EDLC will shorten by half. At temperature lower than normal room temperature, it is possible to apply voltages slightly higher than the rated voltage without significant effects of degradation in performance and reduction in life time. Therefore, it is recommended to use EDLC in low temperature.

At low temperature, increased ESR is only a temporary phenomenon due to the increased viscosity of the electrolyte and slower movement of the ions. At high temperature, ESR increasing will result in permanent degradation and electrolyte decomposition inside the EDLC. The total temperature, ambient temperature add internal temperature rise, should be controlled under the rated maximum temperature. Larger working current and longer life time can be obtained when introduce cooler environment.

Charge method

EDLC stores energy by the physical mechanism of electric charge absorption/desorption at the surface of active carbon electrode. There is not chemical reaction during charge-discharge process, so it can be charged or discharged fast with high current. EDLC can be charged using various methods including constant current, constant power, constant voltage or by paralleling to an energy source (i.e. battery). If an EDLC is configured in parallel with a battery, adding a low value resistor in series will increase the life of the battery.

Technical Information cont.

Series Connection

The voltage of single EDLC is too low(2.7V or 3.0V)for most applications.So EDLC connection in series is used to obtain higher voltage for those application.Since there is slight difference between each EDLC in capacitance and resistance,circuit balance should be considered in the module to prevent single cell exceeds the rated voltage during charge,which would cause performance degradation of the module.

Storage

Do not store the EDLC in the following environments:

High temperature/high humidity environments.

Direct sunlight,dust environment.

Direct contact with the water,salt,oil or other chemicals.

Direct contact with corrosive materials,acids,alkalies or toxic gases.

Shock or vibration environments.

Transportation

EDLC are regulated by the US DOT/IATA transportation regulations.Proper shipping name for EDLC is UN3499 CAPACITOR,electric double layer(with an energy storage capacity greater than 0.3Wh).

Welding

Wave soldering information listed in following table is used only for leads type EDLC:

Excessive heat may result in deterioration of the electrical properties of the EDLC and electrolyte leakage or internal pressure increasing.Follow the specific soldering instructions listed as below:

Do not dip EDLC body into melted solder.Only the lead or welded leg of the EDLC can immerse solder.

Ensure there is no direct contact between the sleeve of the EDLC and the PCB or any other component. Excessive heat may cause sleeve to shrink or crack.

Avoid installing the EDLC on the exposed circuit board to prevent electrical shorts

Hand welding:

Do not contact the sleeve of EDLC with soldering iron,otherwise the sleeve will melt or rupture.The recommended temperature of the soldering rod tip is less than 350°C and the solder duration should be less than 4 seconds.Minimize the time that the soldering iron is in direct contact with the terminals of the EDLC,as excessive heat of the terminal of EDLC may lead to deterioration of EDLC.

Wave soldering:

Use a preheating time not more than 60 seconds for PCB,and preheating temperature should be limited to less than 100°C .Let the thickness of immersion tin layer to be 0.8mm or thicker.

Reflow soldering:

Do not use reflow soldering unless there are specific rated soldering temperature.Use infrared or convection heating method on the EDLC instead

Technical Information cont.

Solder Temperature (°C)	Suggested solder time (S)	Maximum solder time (S)
220	7	9
240	7	9
250	5	7
260	3	5

Ripple Current

EDLC has a higher resistance than aluminum electrolytic capacitor, so it is more susceptible to internal heat generation when exposed to ripple current. The maximum ripple current recommended should not increase the surface temperature of the EDLC by more than 3°C, to avoid heat generation which leads to electrolyte decomposition, increased ESR and reduced life time.

Emergency Applications

If you detect the EDLC overheating or if you smell unique odor, immediately disconnect any power or load to the EDLC. Allow the EDLC to cool down, then dispose it properly. Do not expose your face or hands to an overheating EDLC. Contact the factory for a Material Safety Data Sheet if the EDLC leaks or vents.

If exposed to electrolyte:

·Skin contact: Use soap and water thoroughly wash skin.

·Eye contact: Flush with flowing water or saline, and immediately ask for medical treatment.

Ingestion: Immediately wash with water and ask for medical treatment.

General safety tips

Make sure the EDLC is discharged to below 0.1V at the end of use or test to avoid potential safety hazard caused by short circuit.

EDLC may vent or rupture if overcharged, reverse charged, incinerated or heated above 150°C. Do not crush, mutilate, nail penetrate or disassemble the EDLC. Abuse of EDLC may result in high temperature on aluminum shell which may cause burn hazard.

Do not carelessly dispose EDLC in trash, but dispose according to local regulations.

MSL

Level 1

Table 1 – Ratings & Part Number Reference

Rated Voltage	Rated Capacitance	Size $\Phi D \times L$	Max. ESR		Maximum Continuous Current	Maximum Peak Current	Maximum Leakage Current	Power Density	Maximum Energy	Energy Density	KEMET Part Number
			AC (1kHz/m Ω)	DC IEC (m Ω)							
2.7	220	35x50	1.65	3.2	17.4	174.3	0.8	4,206	0.2228	3.43	SCEQK2206Y2R7SC000
2.7	300	35x60	1.4	2.2	22.7	244	1	5,065	0.3038	3.87	SCEQV3006Y2R7SC000
2.7	400	35x70	1.2	1.6	28.48	329.3	1.3	6,041	0.405	4.48	SCEQP4006Y2R7SC000
2.7	500	35x70	1.2	1.6	28.48	375	1.4	6,041	0.5063	5.59	SCEQP5006Y2R7SC000
2.7	500	35x85	1.1	1.4	33.23	397.1	1.5	6,187	0.5063	5.01	SCEQT5006Y2R7SC000
2.7	600	35x85	1.1	1.4	33.23	440.2	1.6	6,187	0.6075	6.01	SCEQT6006Y2R7SC000
2.7	750	35x100	1	1.3	37.14	512.7	1.8	5,883	0.7594	6.08	SCEQR7506Y2R7SC000
2.7	850	35x110	0.9	1.2	40.39	568.1	1.95	5,080	0.8606	6	SCEQX8506Y2R7SC000
2.7	650	60x55	0.6	0.72	54	598	1.7	7,594	0.6581	4.11	SCEYD6506Y2R7CC000
2.7	1200	60x75	0.4	0.55	70	976	2.8	6,117	1.215	4.67	SCEYE1207Y2R7CC000
2.7	1500	60x85	0.33	0.45	84	1209	3	6,943	1.5188	5.42	SCEYF1507Y2R7CC000
2.7	2000	60x105	0.25	0.35	110	1588	4.2	6,943	2.025	5.63	SCEYG2007Y2R7CC000
2.7	3000	60x140	0.22	0.26	130	2275	5.2	6,729	3.0375	6.08	SCEYP3007Y2R7CC000

Marking

Radial

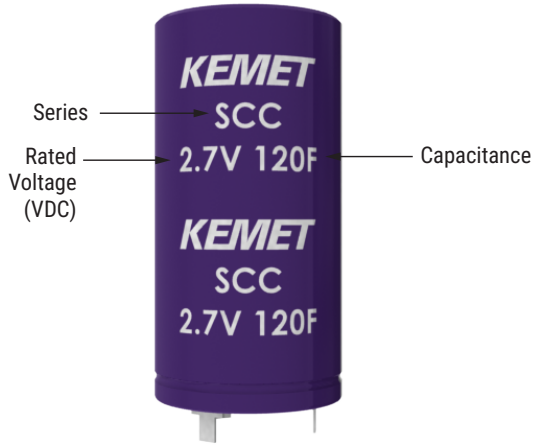

Snap-in

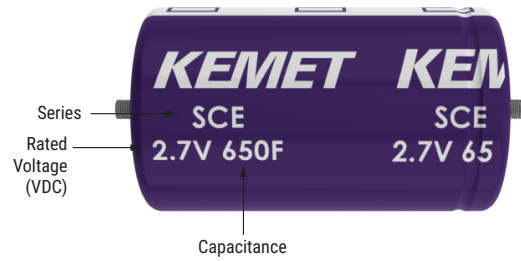

**Image for reference only. A slight change in the layout can occur, not affecting the marking content. This change will not impact the product's form, fit, or function, as the products remain equivalent in physical, mechanical, quality, and reliability characteristics.*

Construction

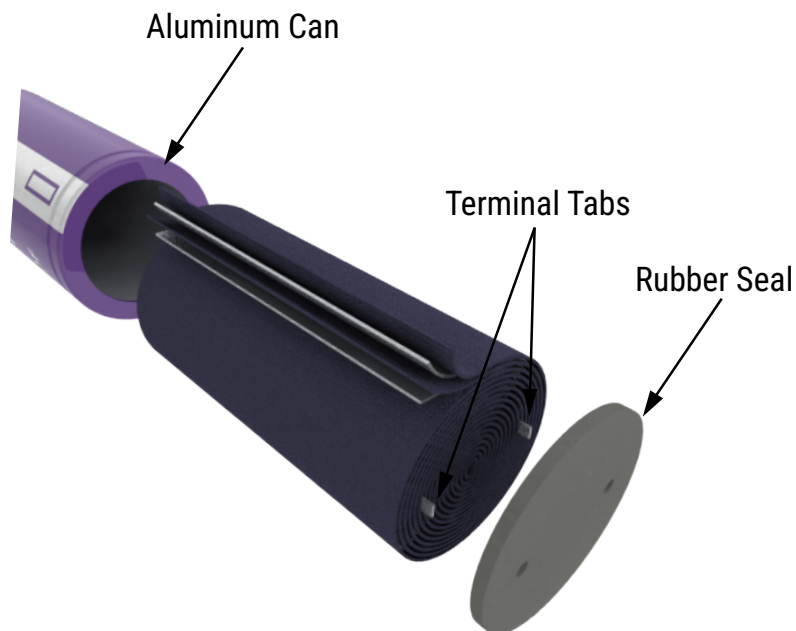

Construction Data

The Supercapacitor manufacturing process begins with the precision mixing of active materials, conductive agents, and binders to form a uniform electrode slurry which is then evenly coated onto aluminum foil current collectors and dried in an oven.

Following this, the dried electrodes are compacted through a calendaring process to achieve the target density and thickness while improving adhesion before being slit into narrow strips and cut into specific lengths and shapes tailored to the required cell size. The core is then formed by winding the positive electrode, separator, and negative electrode together in a precise sequence, after which it is inserted into a robust aluminum or plastic case and connected to the terminals.

To guarantee long-term stability and reliability, the assembled cells undergo high-temperature vacuum baking to remove all traces of moisture before being injected with a precise amount of electrolyte in a strictly controlled dry environment. The cells are then left to rest during an aging period for full electrolyte impregnation into the electrode microstructure, followed by an electrochemical formation phase where initial low-current cycles activate the materials and establish a stable interface layer.

In the final stages, every unit is rigorously graded according to critical performance parameters such as capacity and internal resistance and then securely packaged in vacuum-laminated film or industrial cartons to ensure they meet the highest standards for global shipment.

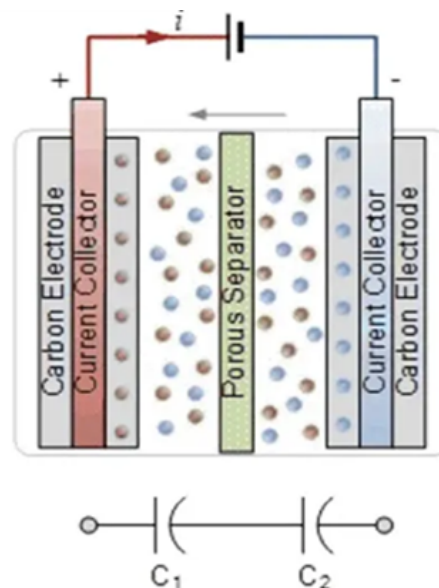
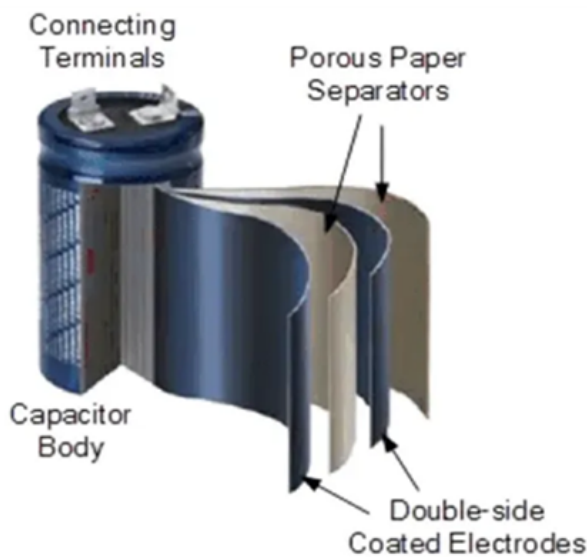
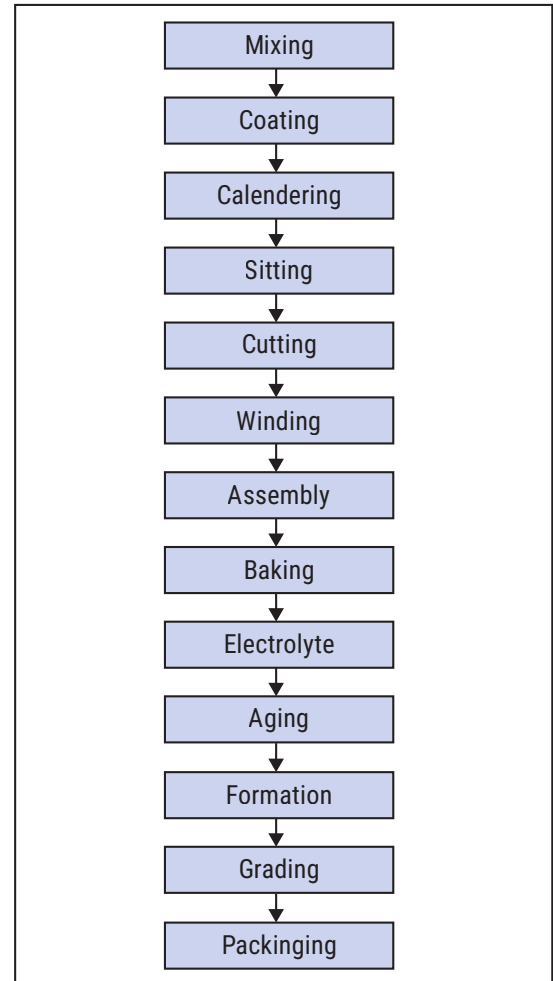

KEMET Electronics Corporation Sales Offices

For a complete list of our global sales offices, please visit <https://www.yageogroup.com/SalesResources/SalesOffices>

Disclaimer

YAGEO Corporation and its affiliates do not recommend the use of commercial or automotive grade products for high reliability applications or manned space flight.

All product specifications, statements, information and data (collectively, the "Information") in this datasheet are subject to change. The customer is responsible for checking and verifying the extent to which the Information contained in this publication is applicable to an order at the time the order is placed. All Information given herein is believed to be accurate and reliable, but it is presented without guarantee, warranty, or responsibility of any kind, expressed or implied.

Statements of suitability for certain applications are based on KEMET Electronics Corporation's ("KEMET") knowledge of typical operating conditions for such applications, but are not intended to constitute – and KEMET specifically disclaims – any warranty concerning suitability for a specific customer application or use. The Information is intended for use only by customers who have the requisite experience and capability to determine the correct products for their application. Any technical advice inferred from this Information or otherwise provided by KEMET with reference to the use of KEMET's products is given gratis, and KEMET assumes no obligation or liability for the advice given or results obtained.

Although KEMET designs and manufactures its products to the most stringent quality and safety standards, given the current state of the art, isolated component failures may still occur. Accordingly, customer applications which require a high degree of reliability or safety should employ suitable designs or other safeguards (such as installation of protective circuitry or redundancies) in order to ensure that the failure of an electrical component does not result in a risk of personal injury or property damage.

Although all product-related warnings, cautions and notes must be observed, the customer should not assume that all safety measures are indicated or that other measures may not be required.

KEMET requires its products to be packaged and shipped on pallets. This is because KEMET's products are specifically designed to be packed onto pallets during shipment. If for any reason, the products are removed from pallets by the shipping party and shipped to the end customer, then additional external protection is required. In this instance, an external box with two carton layers and an upwards orientation sticker must be used by the shipping party, with the empty space filled with filling material, and afterwards sealing the box. If this packing and packaging guideline is not followed by the shipping party, the shipping party, and not KEMET, will be held responsible for any packaging, packing and/or product damages upon delivery of the products to the end customer. KEMET hereby disclaims any liability for damages to the products or otherwise that have been, or threaten to be, inflicted, result from or are in any way related to the packaging, packing or damage by the shipping party in contravention of the packing and packaging guidelines herein.

KEMET is a registered trademark of KEMET Electronics Corporation.