

EMI Common Mode Choke

Automotive Grade

APPM Series



Overview

An EMI common mode choke (CMC) for power lines is a passive component specifically designed to suppress electromagnetic interference (EMI) in power supply circuits. A full series of common mode choke is designed for excellent noise attenuation with compact sizing for use in wide range of applications. Both standard series and custom designs are available.

Benefits

1. Automotive DC Power Line Common Mode Filter
2. Ferrite NiZn core offers high Z@High frequency
3. Ferrite Ni-Zn+MnZn core offers High Z @ Low frequency
4. Operating temperature range – 40°C~125°C
5. Excellent solderability

Applications

1. Networking
2. EMI solutions for charger
3. Media player, Dashboard
4. Battery management
5. Lighting, MCU, Infotainment

Product Information

| Series | Size Code (JIS/EIA) | Impedance(Ω) |
|--------|---------------------|-----------------------|
| APPM | 5050/2020 | 70 ~ 4300 |
| | 7060/2824 | |
| | 9070/3628 | |
| | 1211/4844 | |
| | 1513/6052 | |
| | 4850/1920 | |



APPM00121165 Series Specification

AEC-Q200

1 Scope: This specification applies to the Pb Free DC Power Line Common Mode Filter

2 Part Numbering:

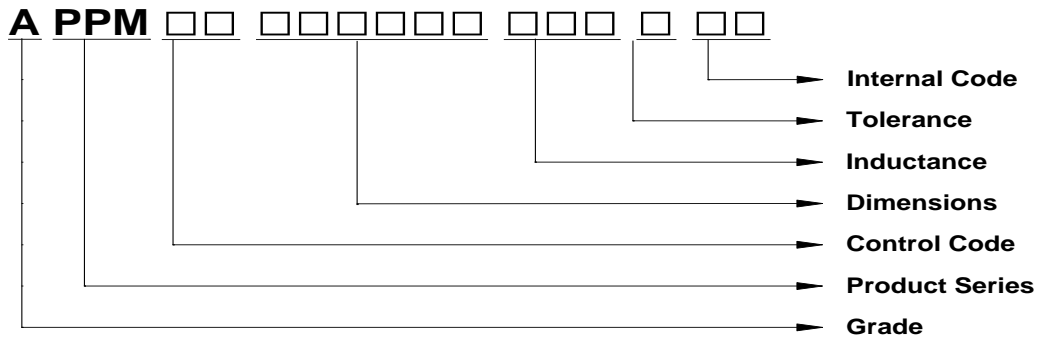

3 Rating:

Operating Temperature range: -40°C ~ +125°C (Including self temp. rise)
 Storage Temperature range: -40°C ~ +125°C (For after the circuit board is mounted)
 Storage Temperature: (on tape & reel): -20°C to +40°C; 75% RH max.

4 Standard Testing Condition:

| | Unless otherwise specified | In case of doubt |
|-------------|----------------------------------|------------------|
| Temperature | Ordinary Temperature(15 to 35°C) | 20 to 30°C |
| Humidity | Ordinary Humidity(25 to 85% RH) | 50 to 80 %RH |

5 Configuration and Dimensions and Unit Weight:

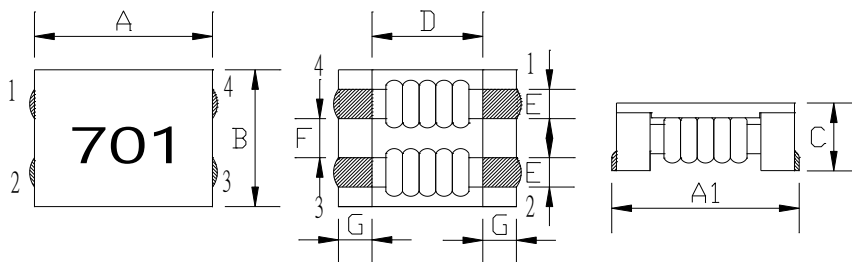

- A: 12.0±0.5 mm
- A1: 12.5±0.5 mm
- B: 10.8±0.5 mm
- C: 6.5 Max. mm
- D: 7.0 Typ. mm
- E: 2.7 Typ. mm
- F: 2.5 Typ. mm
- G: 2.5 Typ. mm

Net Weight (grms)

Marking XXX

Marking color:Black

| SIZE CODE | Net Weight (grms) |
|-----------|-------------------|
| 121165 | 2.68(Typ.) |

6 Electrical Characteristics:

| PT/NO. | Impedance(Ω) at 100MHz | | Test Frequency | Resistance RDC(Ω) Max.(1 line) | Rated Current (A) Max. | Insulation Resistance (M Ω) Min. | Rated Voltage (V)Max. |
|--------------------|------------------------------------|------|-------------------|---|------------------------------|--|-----------------------------|
| | Min. | Typ. | | | | | |
| APPM00121165800XY0 | 80 | 230 | 100MHz/0.5V | 2.2m Typ. | 10 | 10 | 125 |
| APPM00121165701XY0 | 500 | 700 | 100MHz/0.5V | 6.0m | 8 | 10 | 125 |
| APPM00121165801XY0 | 600 | 800 | 100MHz/0.5V | 8.0m | 8 | 10 | 125 |
| APPM00121165102XY0 | 750 | 1000 | 100MHz/0.5V | 14 m | 6 | 10 | 125 |
| APPM00121165222XY0 | 2200 | 2500 | 10MHz/0.5V | 35 m | 1.8 | 10 | 125 |
| APPM00121165272XY0 | 2300 | 2700 | 10MHz/0.5V | 50 m | 1.5 | 10 | 125 |

CIRCUIT DIAGRAM

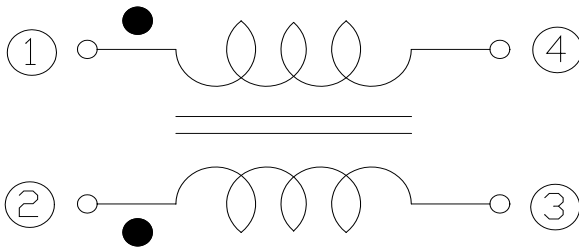

NOTE:

1.Rated DC Current : Based on temperature rise (ΔT : 40 $^{\circ}$ C Typ.)

6 Electrical Characteristics:

(6)-1 Impedance

Measured by HP4291B RF Impedance Analyzer.

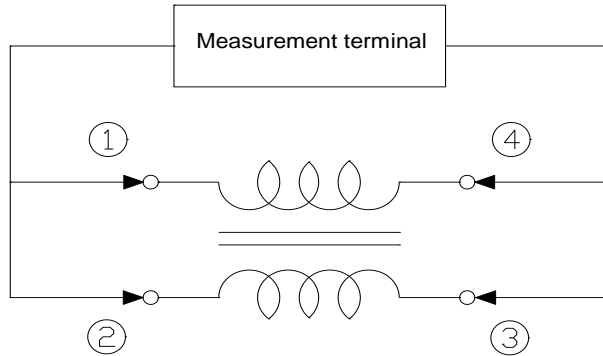

(6)-2 DC Resistance

Measured by Chroma 16502 milliohm meter.

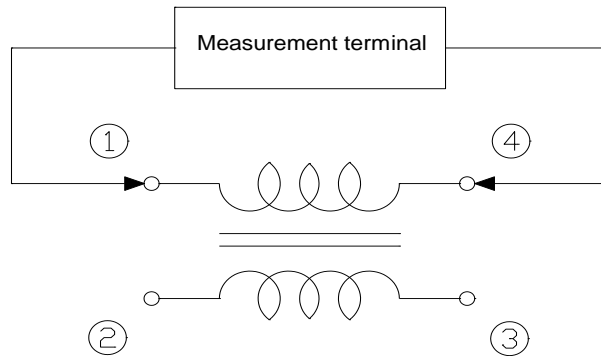

(6)-3 Insulation Resistance

Measured by Chroma 19073

Measurement voltage : 50V ,Measurement time : 3 sec.

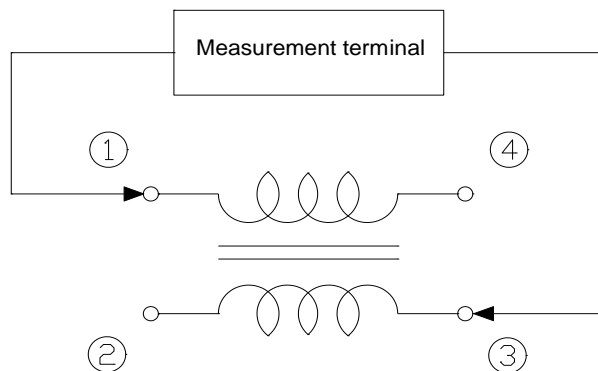

6.1 Construction:

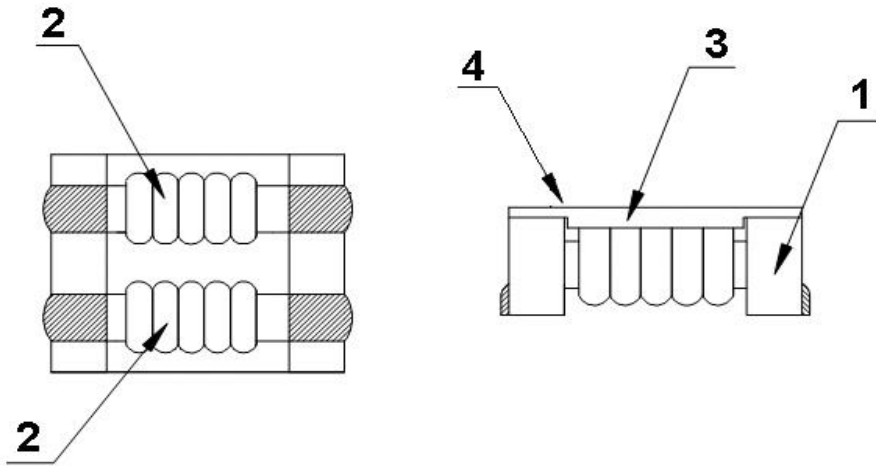

6.2 Material List:

| NO. | ITEM | DESCRIPTION & TYPE |
|-----|---------|--------------------|
| 1 | CORE | FERRITE |
| 2 | Wire | Magnet Wire |
| 3 | Cover | LCP |
| 4 | Marking | INK |

MECHANICAL

| TEST ITEM | SPECIFICATIONS | TEST CONDITIONS |
|---|--|--|
| Solderability | No more than 5% of the solderable metalization exposed underlying, non-wettable base metal or metalization layers or portions of the ceramic substrate after exposure to molten solder. | Refer to J-STD-002 For both Leaded & SMD. Electrical Test not required. Test Method B @ 245±5°C, dwell for 5+0/-0.5 seconds |
| Resistance to Soldering heat (reflow soldering) | There shall be no damage or problems. | <p>Temperature profile of reflow soldering</p> <p>Note: 1. Re-Flow Possible times: within 3 times 2. Nitrogen adopted is recommended while in re-flow</p> |
| Terminal strength | The terminal electrode and the ferrite must not be damaged. | With the component mounted on a PCB obtained from the Supplier with the device to be tested, apply a 17.7 N (1.8 Kg) force to the side of a device being tested. This force shall be applied for 60 +1 seconds. Also the force shall be applied gradually as not to apply a shock to the component being tested. |
| Strength on PC board bending | The terminal electrode and the ferrite must not be damaged. | <p>Test device shall be soldered on the substrate</p> <p>Substrate Dimension: 100x40x1.6mm</p> <p>Deflection: 2.0mm</p> <p>Keeping Time: 60 sec</p> |
| High Temperature Exposure (Storage) | <p>Impedance: Within ±20% of the initial value.</p> <p>Insulation resistance and DC resistance on the specification shall be met.</p> <p>The terminal electrode and the ferrite must not be damaged.</p> | 1000hrs. at rated operating temperature, part can be stored for 1000 hrs. @ 150°C. Unpowered. Measurement at 24±4 hours after test conclusion. |

APPM00121165 Series Specification

AEC-Q200

ENVIRONMENT CHARACTERISTICS

| TEST ITEM | SPECIFICATIONS | TEST CONDITIONS |
|---------------------------------|---|--|
| Humidity Bias | <p>Impedance: Within $\pm 20\%$ of the initial value.</p> <p>Insulation resistance and DC resistance on the specification shall be met.</p> <p>The terminal electrode and the ferrite must not be damaged.</p> | <p>Precondition: Reflow peak temperature 260°C 3 times. (Reference: J-STD-020)</p> <p>1000 hours 85°C/85%RH. Unpowered. Measurement at 24\pm4 hours after test conclusion.</p> |
| Vibration | <p>Impedance: Within $\pm 20\%$ of the initial value.</p> <p>Insulation resistance and DC resistance on the specification shall be met.</p> <p>The terminal electrode and the ferrite must not be damaged.</p> | <p>MIL-STD-202 Method 204</p> <p>5 g's for 20 minutes, 12 cycles each of 3 orientations.</p> <p>Test from 10-2000Hz.</p> |
| Temperature Cycling | <p>Impedance: Within $\pm 20\%$ of the initial value.</p> <p>Insulation resistance and DC resistance on the specification shall be met.</p> <p>The terminal electrode and the ferrite must not be damaged.</p> | <p>Precondition: Reflow peak temperature 260°C 3 times. (Reference: J-STD-020)</p> <p>1000 cycles (-55°C to +150°C). Measurement at 24\pm4 hours after test conclusion. 30min maximum dwell time at each temperature extreme. 1 min. maximum transition time.</p> |
| High Temperature Operating Life | <p>Impedance: Within $\pm 20\%$ of the initial value.</p> <p>Insulation resistance and DC resistance on the specification shall be met.</p> <p>The terminal electrode and the ferrite must not be damaged.</p> | <p>Precondition: Reflow peak temperature 260°C 3 times. (Reference: J-STD-020)</p> <p>1000 hrs. @ 125 °C, apply maximum rated power. Measurement 24\pm4 hours after test conclusion.</p> |
| Physical Dimensions | <p>Verify physical dimensions to the applicable component detail specification.</p> | <p>Any applicable method using x10 magnification, micrometers, calipers, gauges, contour projectors, or other measuring equipment, capable of determining the actual specimen dimensions.</p> |
| Mechanical Shock | <p>1. Electrical characterization- Impedance: Within $\pm 20\%$ change range</p> <p>2. Appearance-No damage (OM)</p> | <p>Units are non-operating.</p> <p>Pulse shape : Half-sine waveform</p> <p>Impact acceleration : 100 g's</p> <p>Pulse duration : 6 ms</p> <p>Number of shocks : 18 shocks (3 shocks for each face)</p> |
| Flammability | <p>The marking and A side have no obvious broken, and the marking are clearly</p> | <p>Refer to UL 94</p> <p>Burning stops within 10 seconds on a vertical specimen; drips of particles allowed as long as they are not inflamed.</p> |

7 Packaging:

7.1 Packaging -Cover Tape

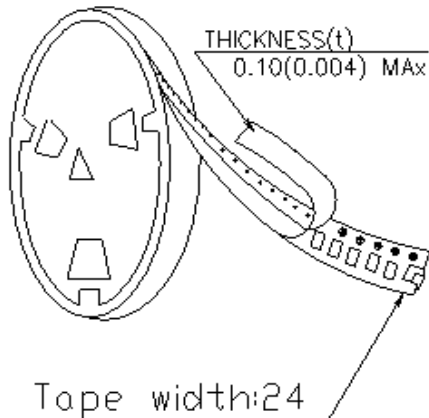

7.2 Packaging Quantity

| TYPE | PCS/REEL |
|--------------|----------|
| APPM00121165 | 500 |

7.3 Reel Dimensions

Unit : mm

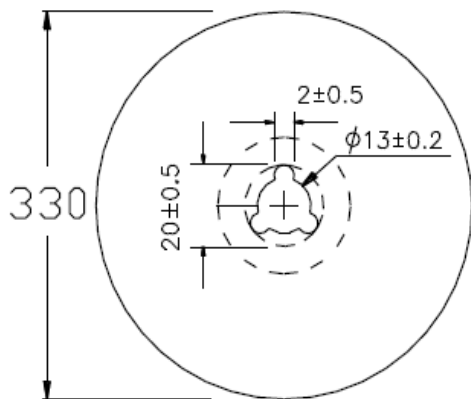

7 Packaging:

7.4 Tape Dimensions in mm

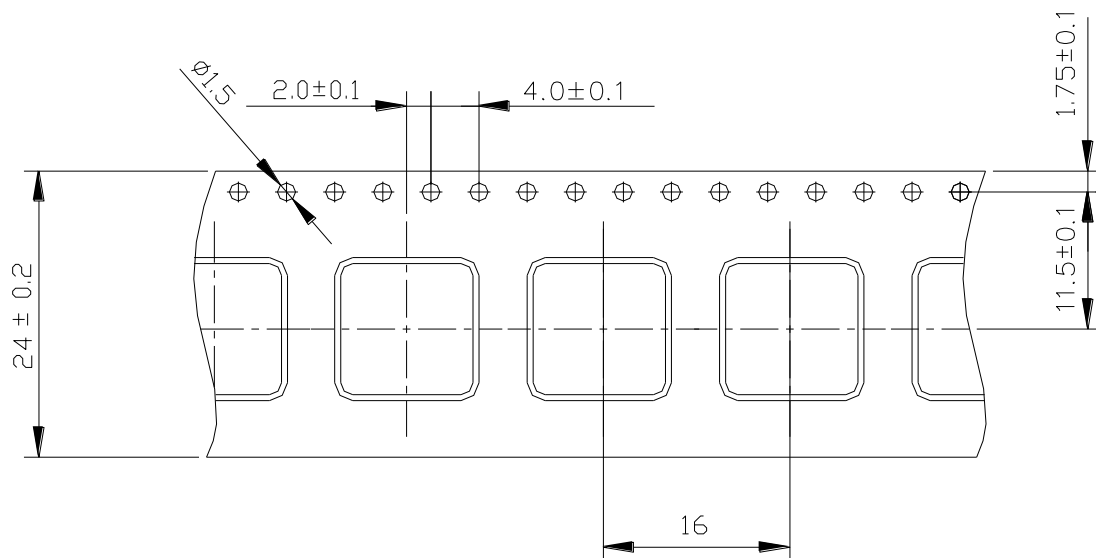

Unreeling Direction

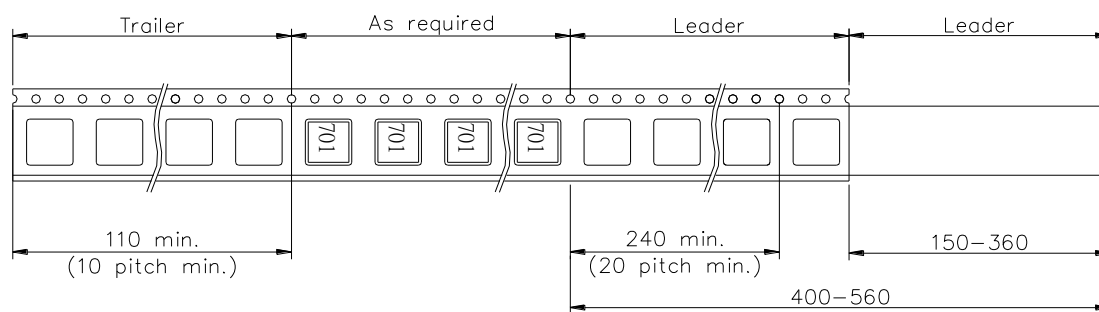
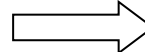

8 Recommended Land Pattern:

(STANDARD PATTERN) Unit : mm

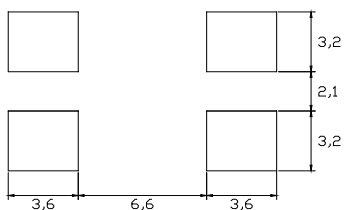

9 **Note:**

1. Please make sure that your product has been evaluated and confirmed against your specifications when our product is mounted to your product.
2. Do not knock or drop.
3. All the items and parameters in this product specification have been prescribed on the premise that our product is used for the purpose, under the condition and in the environment agreed upon between you and us. You are requested not to use our product deviating from such agreement.
4. Please keep the distance between transformer/coil and other components (refer to the standard IEC 950)
5. The moisture sensitivity level (MSL) of products is classified as level 1.
6. Suggestion
On customer side this product series need to be fixed by the glue after IR reflow.

Please refer to below example photo:



TYPICAL ELECTRICAL CHARACTERISTICS

Frequency vs impedance

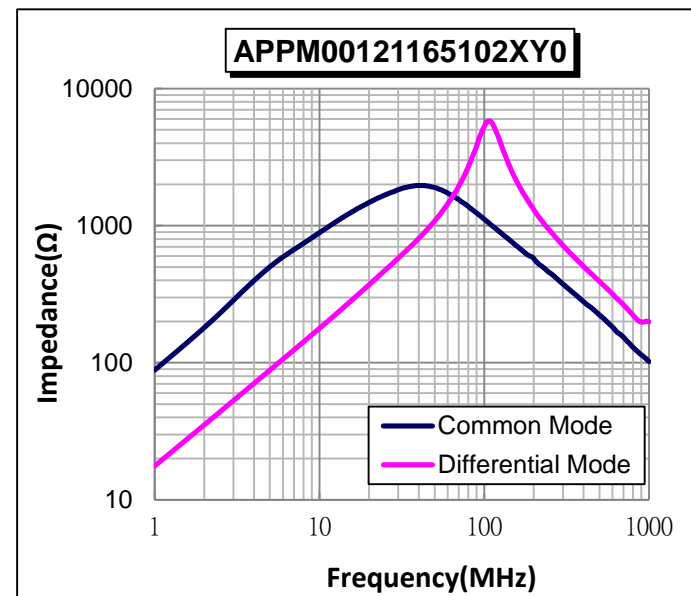
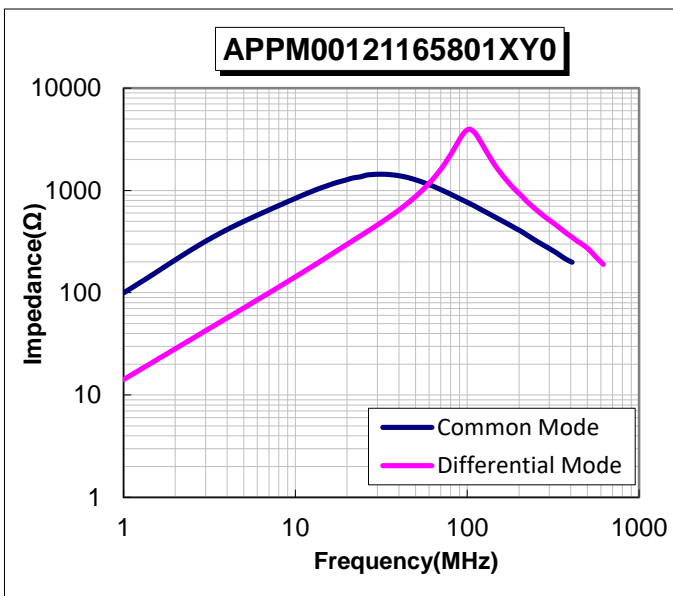
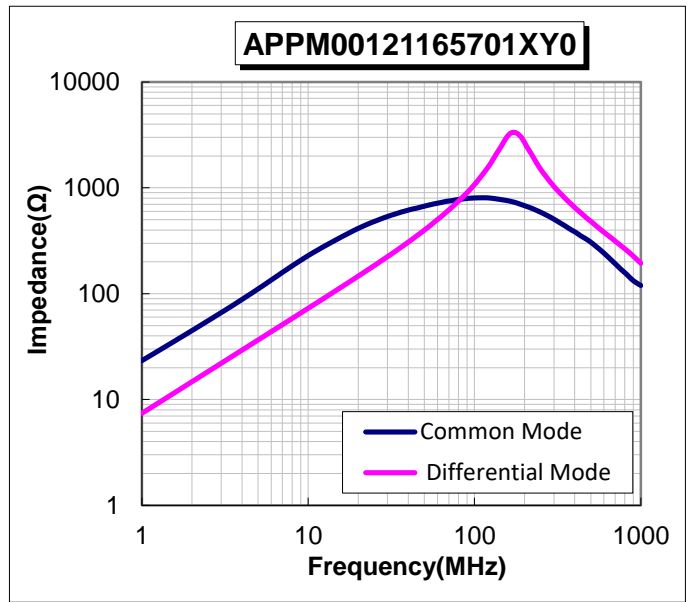
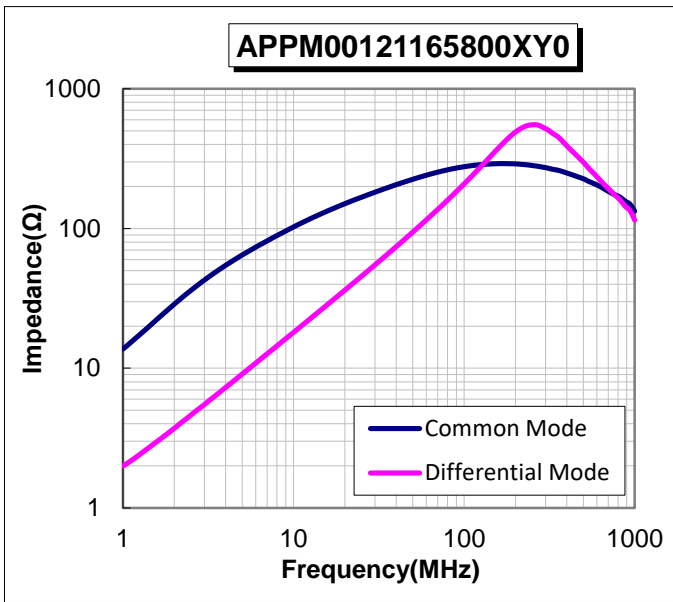

TYPICAL ELECTRICAL CHARACTERISTICS

Frequency vs impedance

