

# Power Inductor

## BPMV Series



### Overview

Power inductors are passive electronic components used in various circuits to store energy in a magnetic field when electrical current flows through them. They are critical in filtering, energy storage, and noise suppression in power electronic systems.

They are designed to handle higher currents and are optimized for minimal power loss and thermal efficiency.

### Benefits

1. Ferrite SMD Shielded Type
2. Surface mount inductors designed for high speed, high current switch mode Surface mount inductors designed for high speed, high current switch mode applications requiring lower inductance
3. Gapped ferrite cores for maximum efficiency Customized specifications are available

### Applications

1. Voltage regulator modules (VRMs) for servers, microprocessors
2. High frequency, high current switching power supplies

### Product Information

Series	L (mm)	W(mm)	T (mm)	Inductance (μH)
BPMV	7.6	8.1	12.0	0.09 ~ 0.47
	10.0	4.6	6.0	
	10.0	4.4	6.0	
	9.6	6.45	9.0	
	9.6	6.4	9.0	
	10.0	6.0	12.0	
	10.0	7.0	10.0	
	10.7	7.5	9.5	
	10.7	7.5	12.0	

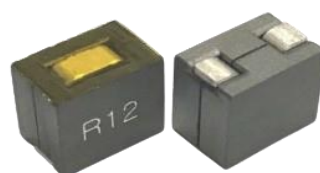

## BPMV00080812 Series Specification

**1 Scope:** This specification applies to the Pb Free high current type SMD inductors

**2 Part Numbering:**

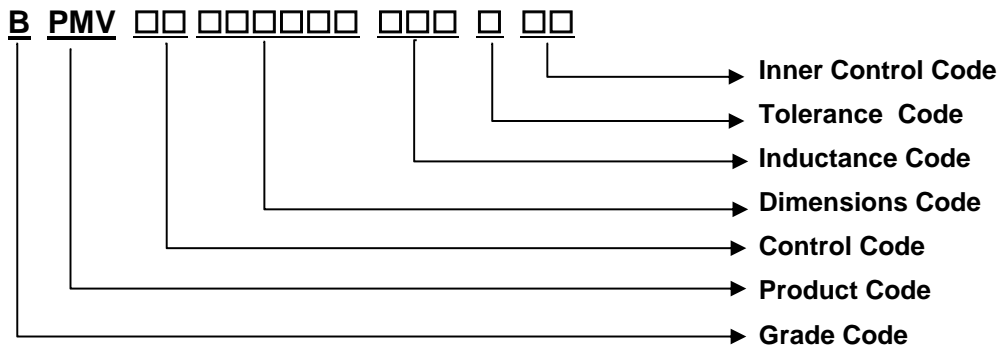

**3 Rating:**

Operating Temperature:  $-40^{\circ}\text{C} \sim 125^{\circ}\text{C}$  (Including self - temperature rise)  
 Storage Temperature: (on tape & reel):  $-20^{\circ}\text{C}$  to  $+40^{\circ}\text{C}$ ; 75% RH max.

**4 Standard Testing Condition:**

	Unless otherwise specified	In case of doubt
Temperature	Ordinary Temperature( $15$ to $35^{\circ}\text{C}$ )	$20$ to $30^{\circ}\text{C}$
Humidity	Ordinary Humidity( $25$ to $85\%$ RH)	$50$ to $80\%$ RH

**5 Configuration and Dimensions and Unit Weight:**

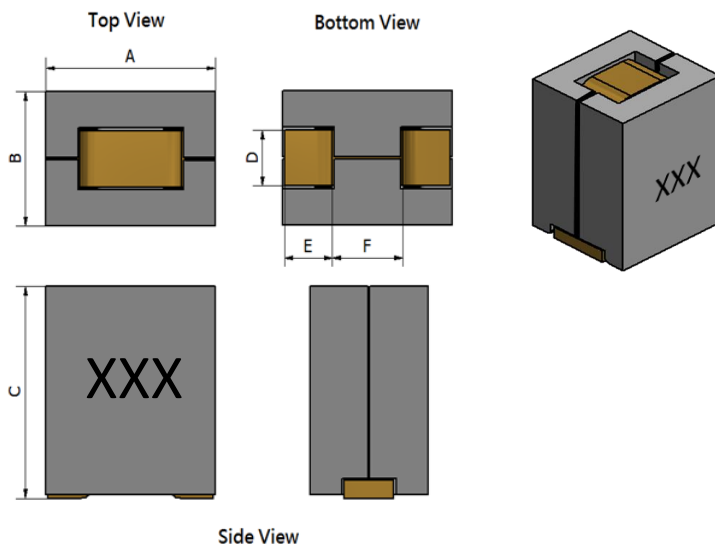

A:	7.6 Max.	mm
B:	8.1 Max.	mm
C:	12.0 Max.	mm
D:	$4.4 \pm 0.1$	mm
E:	2.0 Typ.	mm
F:	3.1 Typ.	mm

Marking XXX

Marking color: Black

Net Weight (grms)

SIZE CODE	Net Weight (grms)
080812	3.33(Typ.)

## BPMV00080812 Series Specification

### 6 Electrical Characteristics:

Part No.	Inductance L(nH)	Resistance RDC(mΩ)	Rated DC Current			Tolerance	Marking
			Isat 1(A)	Isat 2(A)	Irms(A)		
BPMV00080812R12□0E	120	0.155±10%	95	79	60	K,L,M	R12
BPMV00080812R15□0E	150	0.155±10%	86	73	60	K,L,M	R15
BPMV00080812R17□0E	170	0.155±10%	75	64	60	K,L,M	R17
BPMV00080812R22□0E	220	0.155±10%	57	48	60	K,L,M	R22
BPMV00080812R32□0E	320	0.155±10%	37	31	60	K,L,M	R32

### RDC TEST POINT

The nominal DCR is measured from point "a" to point "b" .

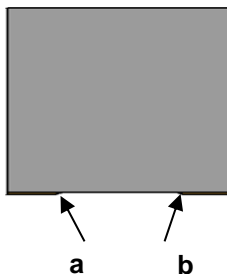

NOTE: tolerance K=±10% , L=±15% ,M=±20%

1. Test Frequency:100kHz/1.0V

2. Isat1 : Based on inductance change ( $\Delta L/L_0$  : drop 20% Typ.)@ ambient temp. 25°C

3. Isat2 : Based on inductance change ( $\Delta L/L_0$  : drop 20% Typ.)@ ambient temp. 100°C

4. Irms : Based on temperature rise ( $\Delta T$  : 40°C TYP.)

**BPMV00080812 Series Specification**

**6.1 Construction:**

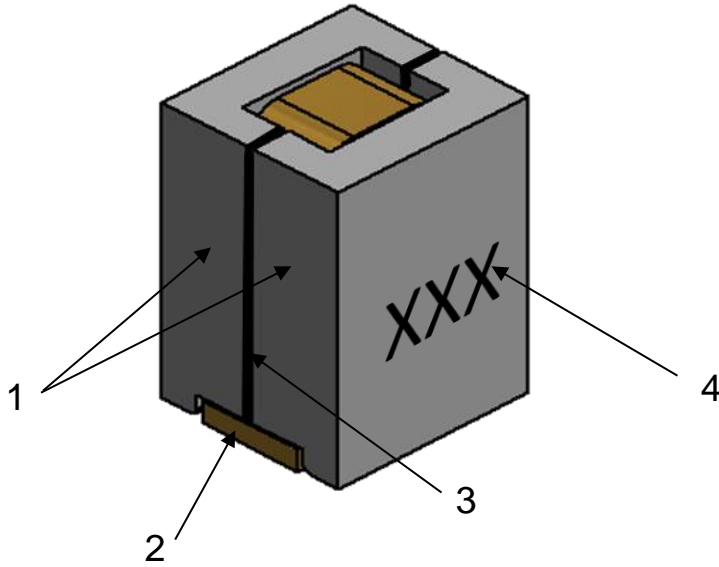

**6.2 Material List:**

NO.	ITEM	DESCRIPTION & TYPE
1	CORE	FERRITE
2	CLIP	COPPER FOIL
3	ADHESIVE	EPOXY RESIN
4	INK	Ink(Black)

**BPMV00080812 Series Specification**

**ELECTRICAL**

TEST ITEM	SPECIFICATION	TEST DETAILS
Temperature characteristics	$\Delta L/L20^{\circ}\text{C} \leq \pm 10\%$ 0~2000 ppm/ $^{\circ}\text{C}$	The test shall be performed after the sample has stabilized in an ambient temperature of -20 to +85 $^{\circ}\text{C}$ , and the value calculated based on the value applicable in a normal temperature and normal humidity shall be $\Delta L/L20^{\circ}\text{C} \leq \pm 10\%$ .

**MECHANICAL**

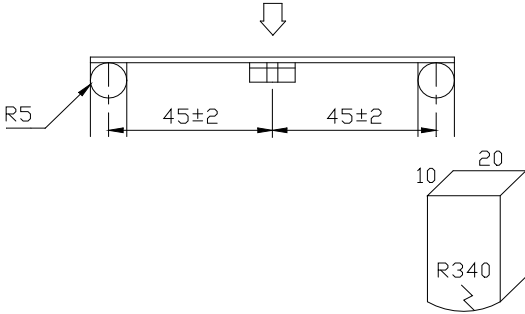
TEST ITEM	SPECIFICATION	TEST DETAILS
Substrate bending	$\Delta L/L_0 \leq \pm 10\%$  There shall be no mechanical damage or electrical damage.	<p>The sample shall be soldered onto the printed circuit board in figure 1 and a load applied until the figure in the arrow direction is made approximately 3mm. (keep time 30 seconds)</p> <p>PCB dimension shall be the page 7/9</p> <p style="text-align: center;"><b>F(Pressurization)</b></p>  <p style="text-align: center;"><b>PRESSURE ROD</b> figure-1</p>

**BPMV00080812 Series Specification**

**MECHANICAL**

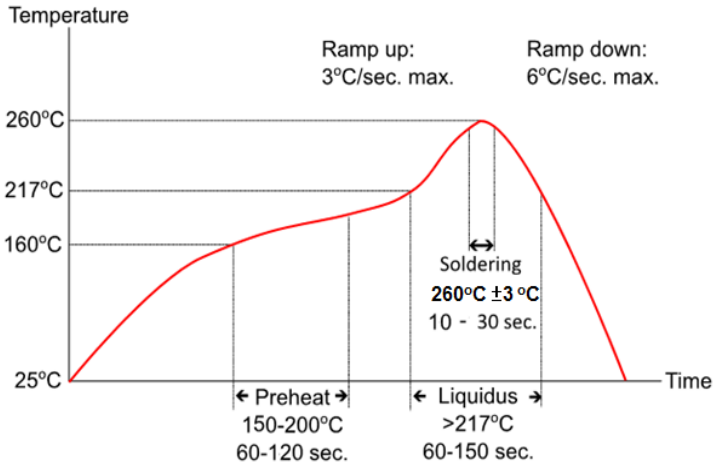
TEST ITEM	SPECIFICATION	
Vibration	$\Delta L/Lo \leq \pm 10\%$  There shall be no mechanical damage.	The sample shall be soldered onto the printed circuit board and when a vibration having an amplitude of 1.52mm and a frequency of from 10 to 55Hz/1 minute repeated should be applied to the 3 directions (X,Y,Z) for 2 hours each. (A total of 6 hours)
Solderability	New solder More than 90%	Flux (rosin, isopropyl alcohol{JIS-K-1522}) shall be coated over the whole of the sample before hard, the sample shall then be preheated for about 2 minutes in a temperature of 130~150°C and after it has been immersed to a depth 0.5mm below for 3±0.2 seconds fully in molten solder M705 with a temperature of 245±5°C.  More than 90% of the electrode sections shall be covered with new solder smoothly when the sample is taken out of the solder bath.
Resistance to Soldering heat (reflow soldering)	There shall be no damage or problems.	<p style="text-align: center;"><b>Temperature profile of reflow soldering</b></p>  <p>The specimen shall be passed through the reflow oven with the condition shown in the above profile for 1 time.</p> <p>The specimen shall be stored at standard atmospheric conditions for 1 hour, after which the measurement shall be made.</p>

## BPMV00080812 Series Specification

### ENVIRONMENT CHARACTERISTICS

TEST ITEM	SPECIFICATION																
High temperature storage	$\Delta L/Lo \leq \pm 10\%$  There shall be no mechanical damage.	The sample shall be left for $96 \pm 4$ hours in an atmosphere with a temperature of $125^\circ\text{C}$ and a normal humidity.  Upon completion of the measurement shall be made after the sample has been left in a normal temperature and normal humidity for 1 hour.															
Low temperature storage	$\Delta L/Lo \leq \pm 10\%$  There shall be no mechanical damage.	The sample shall be left for $96 \pm 4$ hours in an atmosphere with a temperature of $-40 \pm 3^\circ\text{C}$ .  Upon completion of the test, the measurement shall be made after the sample has been left in a normal temperature and normal humidity for 1 hour.															
Change of temperature	$\Delta L/Lo \leq \pm 10\%$  There shall be no other damage of problems	The sample shall be subject to 5 continuous cycles, such as shown in the table 2 below and then it shall be subjected to standard atmospheric conditions for 1 hour, after which measurement shall be made. <div style="text-align: center; margin-top: 20px;"> <p>table 2</p> <table border="1"> <thead> <tr> <th></th> <th>Temperature</th> <th>Duration</th> </tr> </thead> <tbody> <tr> <td>1</td> <td><math>-40 \pm 3^\circ\text{C}</math> (Thermostat No.1)</td> <td>30 min.</td> </tr> <tr> <td>2</td> <td>Standard atmospheric</td> <td>No.1→No.2</td> </tr> <tr> <td>3</td> <td><math>125 \pm 2^\circ\text{C}</math> (Thermostat No.2)</td> <td>30 min.</td> </tr> <tr> <td>4</td> <td>Standard atmospheric</td> <td>No.2→No.1</td> </tr> </tbody> </table> </div>		Temperature	Duration	1	$-40 \pm 3^\circ\text{C}$ (Thermostat No.1)	30 min.	2	Standard atmospheric	No.1→No.2	3	$125 \pm 2^\circ\text{C}$ (Thermostat No.2)	30 min.	4	Standard atmospheric	No.2→No.1
	Temperature	Duration															
1	$-40 \pm 3^\circ\text{C}$ (Thermostat No.1)	30 min.															
2	Standard atmospheric	No.1→No.2															
3	$125 \pm 2^\circ\text{C}$ (Thermostat No.2)	30 min.															
4	Standard atmospheric	No.2→No.1															
Moisture storage	$\Delta L/Lo \leq \pm 10\%$  There shall be no mechanical damage.	The sample shall be left for $96 \pm 4$ hours in a temperature of $40 \pm 2^\circ\text{C}$ and a humidity(RH) of 90~95%.  Upon completion of the test, the measurement shall be made after the sample has been left in a normal temperature and normal humidity more than 1 hour.															

**Test conditions :**

The sample shall be reflow soldered onto the printed circuit board in every test.

## BPMV00080812 Series Specification

### 7 Packaging:

#### 7.1 Packaging -Cover Tape

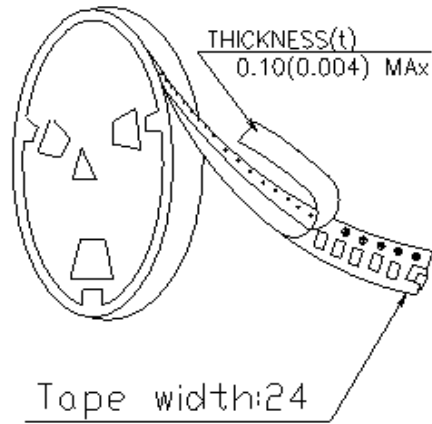

#### 7.2 Packaging Quantity

TYPE	PCS/REEL
BPMV00080812	300

#### 7.3 Reel Dimensions

Unit : mm

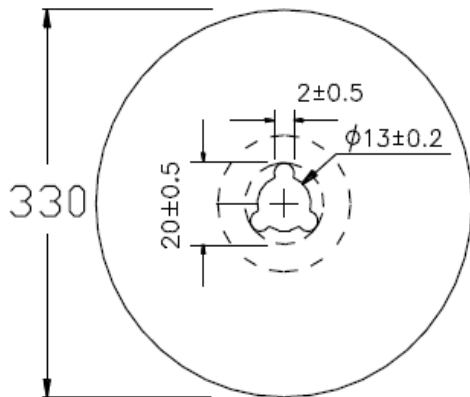

## BPMV00080812 Series Specification

### 7 Packaging:

#### 7.4 Tape Dimensions in mm

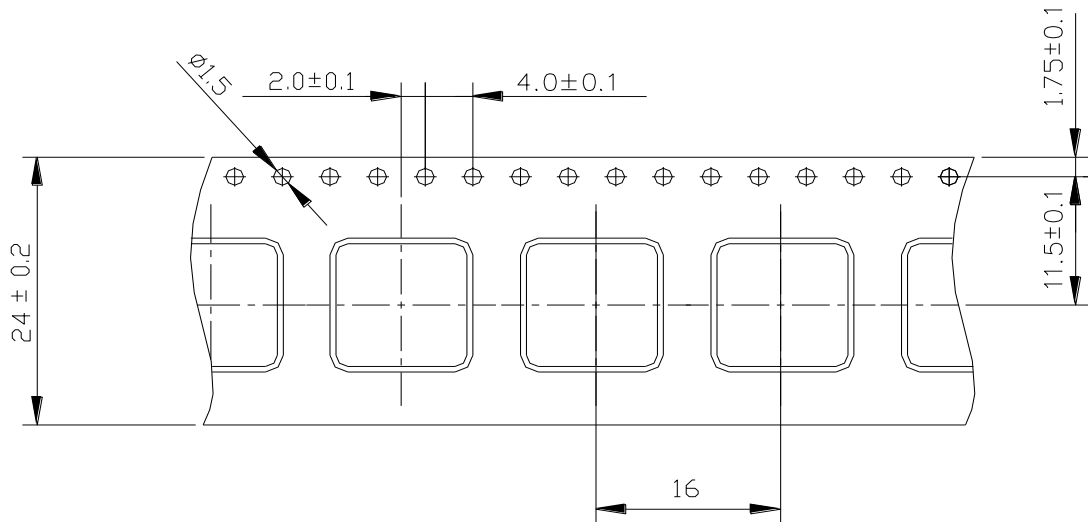

**Unreeling  
Direction**

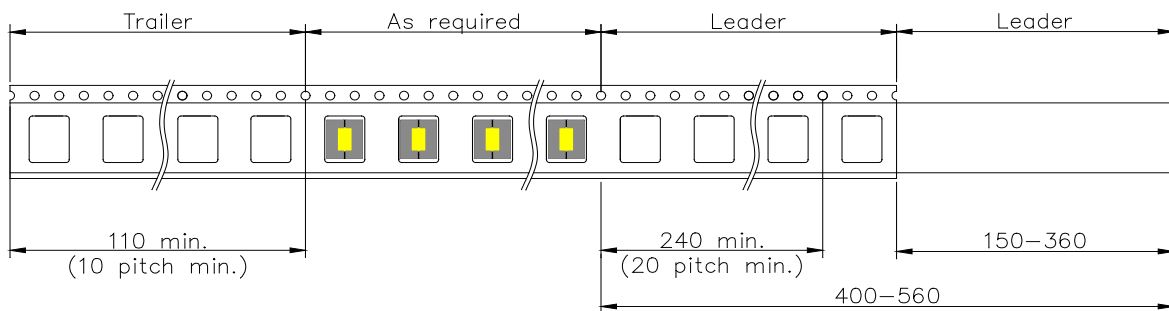

### 8 Recommended Land Pattern:

(STANDARD PATTERN) Unit : mm

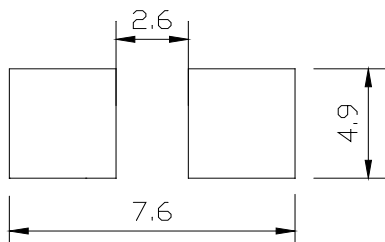

## BPMV00080812 Series Specification

### **9** Note:

1. Please make sure that your product has been evaluated and confirmed against your specifications when our product is mounted to your product.
2. Do not knock or drop.
3. All the items and parameters in this product specification have been prescribed on the premise that our product is used for the purpose, under the condition and in the environment agreed upon between you and us. You are requested not to use our product deviating from such agreement.
4. Please keep the distance between transformer/coil and other components  
(refer to the standard IEC 950)
5. The moisture sensitivity level (MSL) of products is classified as level 1.
6. SHELF LIFE  
Storage Condition: The temperature should be within -40°C ~105°C and humidity should be less than 75%RH. The product should be used within 12 months from the time of delivery.  
In addition, suggest to use product within 6 months from the time of delivery.

## BPMV00080812 Series Specification

### TYPICAL ELECTRICAL CHARACTERISTICS

INDUCTANCE vs. DC CURRENT@100KHz/1.0V

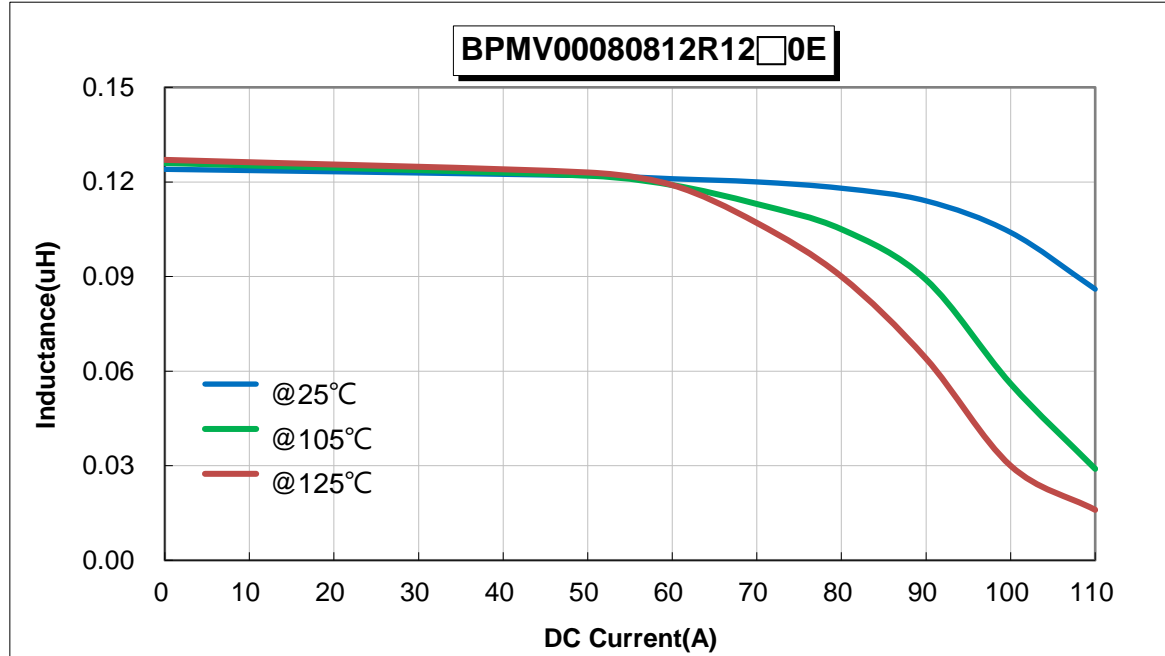

### TEMPERATURE vs. DC CURRENT

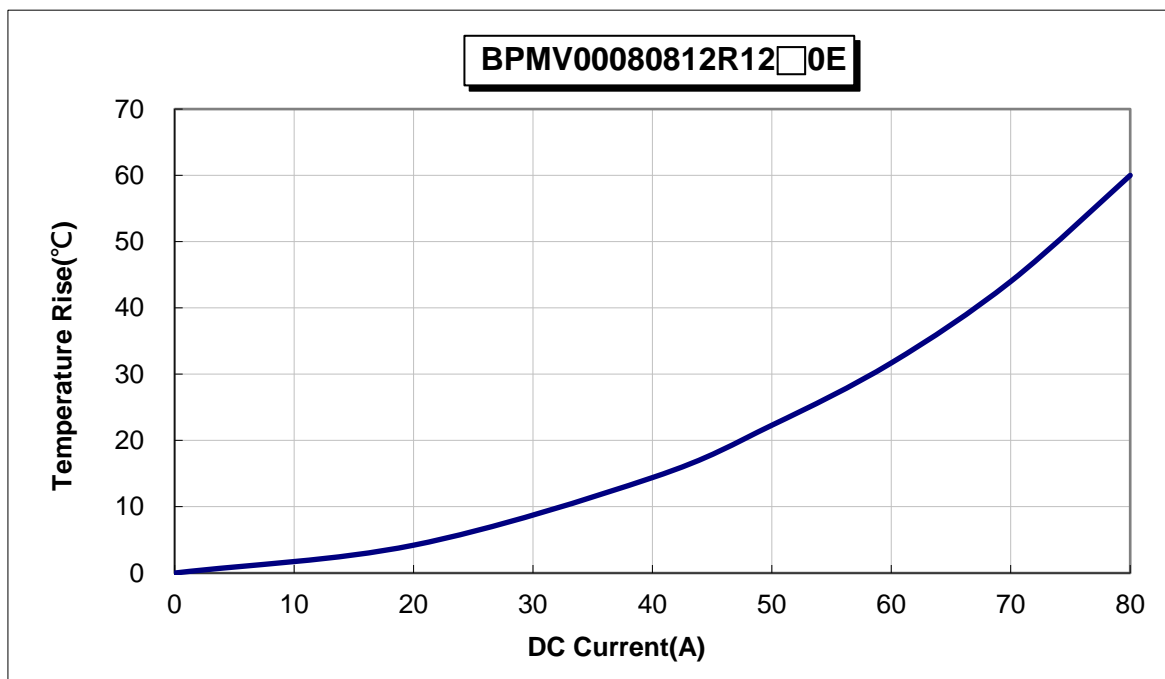

## BPMV00080812 Series Specification

### TYPICAL ELECTRICAL CHARACTERISTICS

INDUCTANCE vs. DC CURRENT@100KHz/1.0V

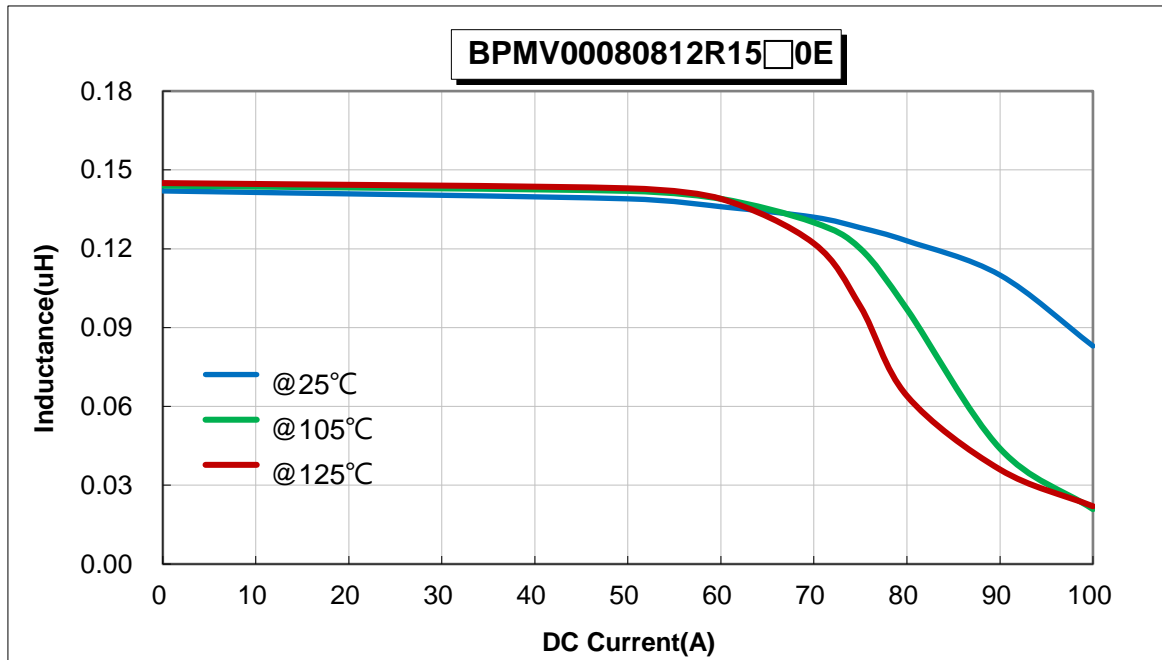

### TEMPERATURE vs. DC CURRENT

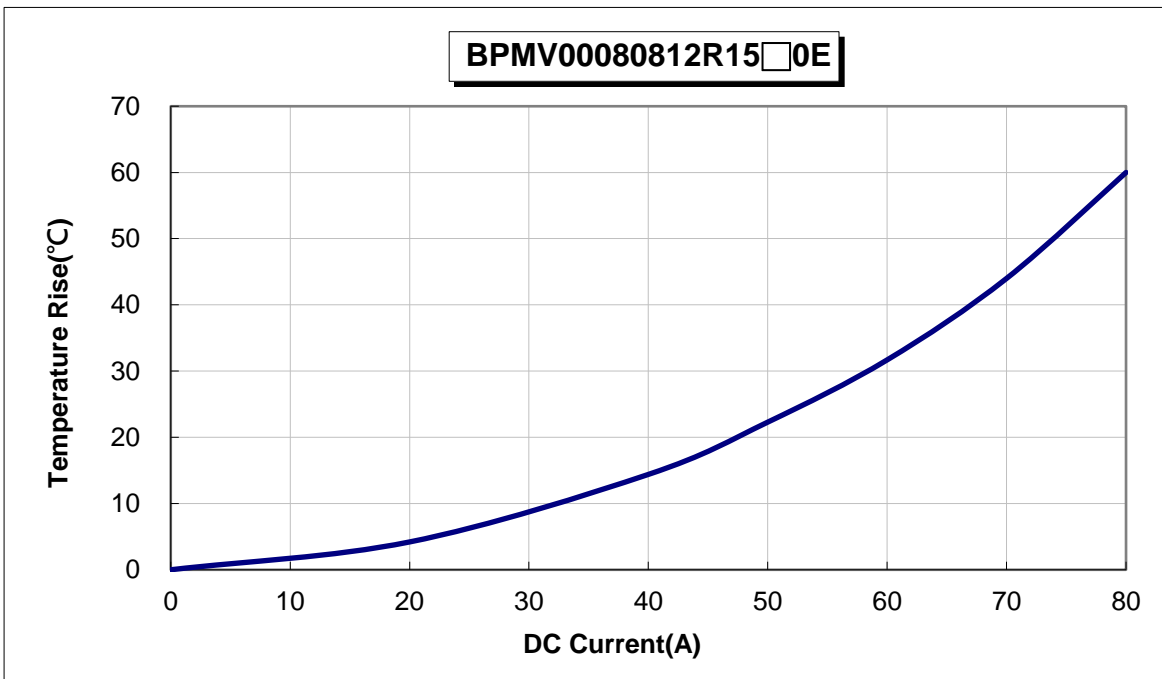

## BPMV00080812 Series Specification

### TYPICAL ELECTRICAL CHARACTERISTICS

#### INDUCTANCE vs. DC CURRENT@100KHz/1V

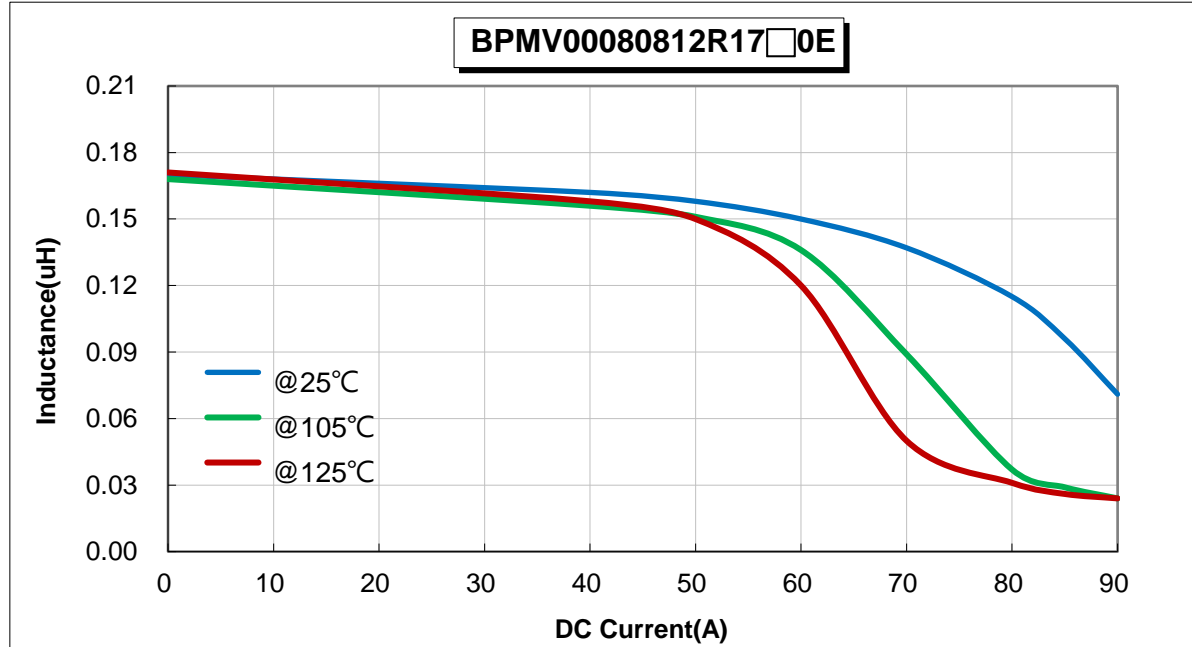

#### TEMPERATURE vs. DC CURRENT

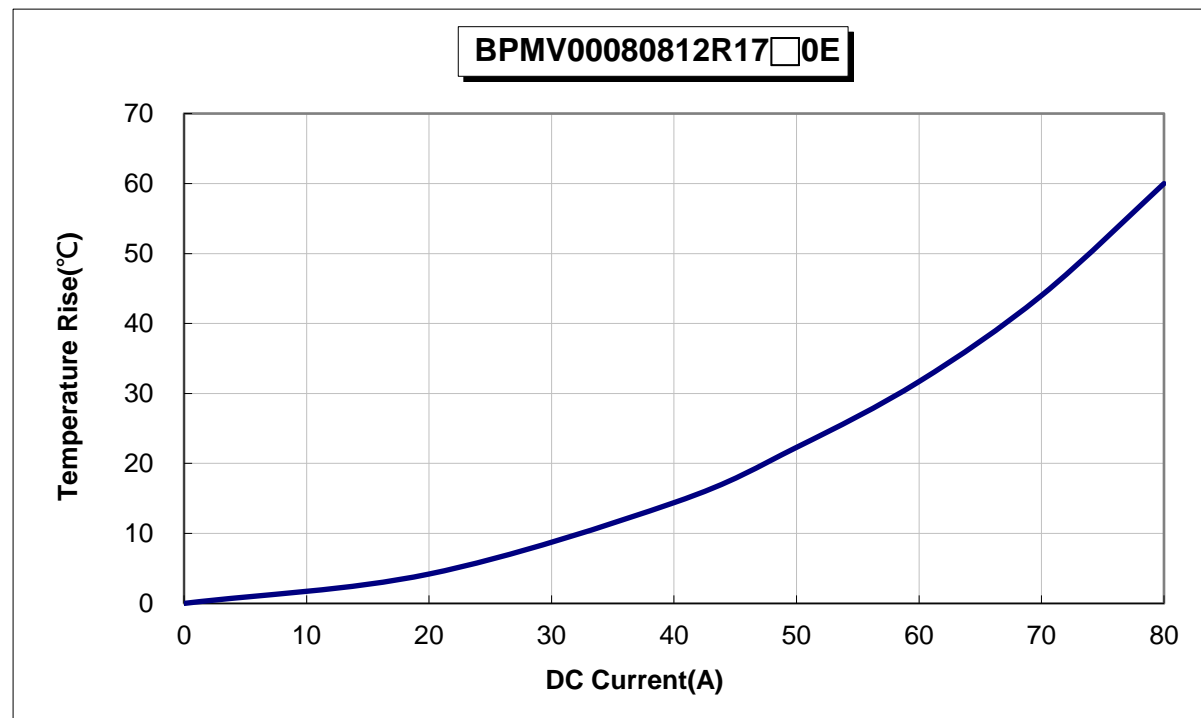

## BPMV00080812 Series Specification

### TYPICAL ELECTRICAL CHARACTERISTICS

INDUCTANCE vs. DC CURRENT@100KHz/1.0V

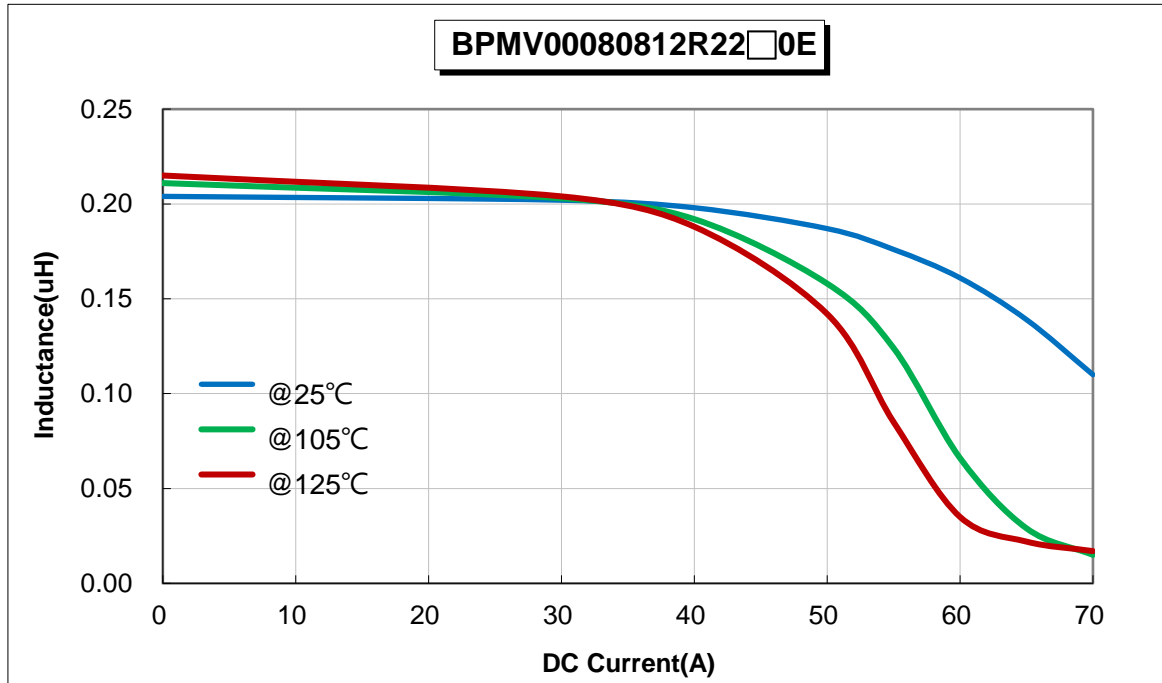

### TEMPERATURE vs. DC CURRENT

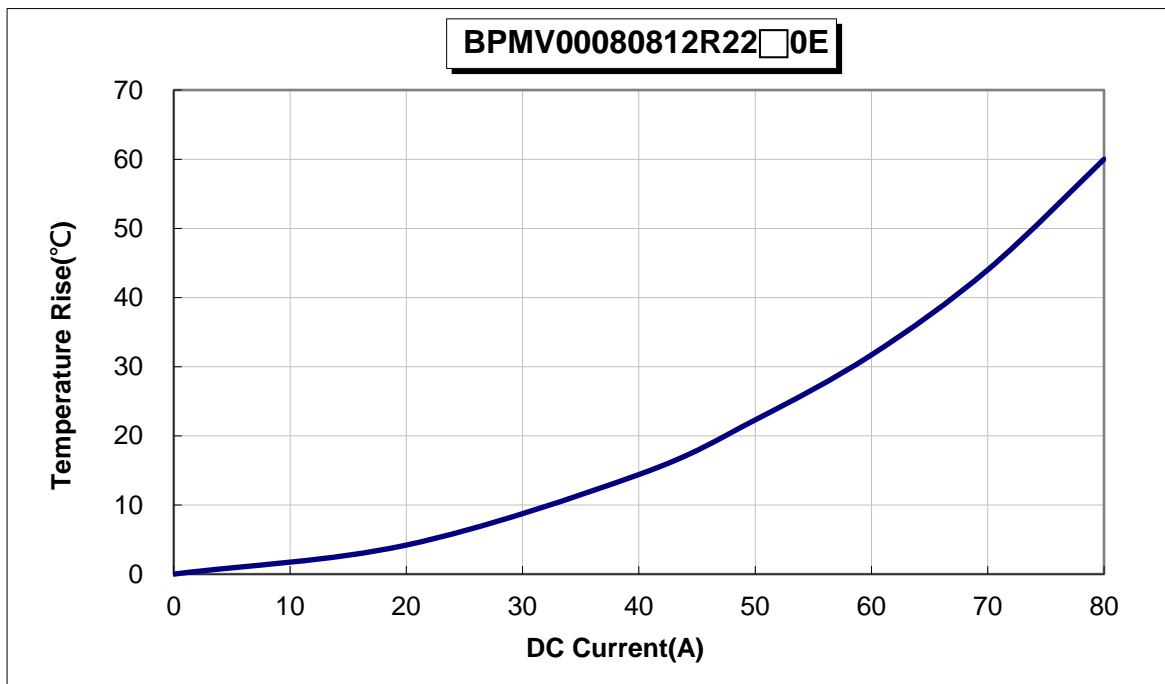

## BPMV00080812 Series Specification

### TYPICAL ELECTRICAL CHARACTERISTICS

INDUCTANCE vs. DC CURRENT@100KHz/1.0V

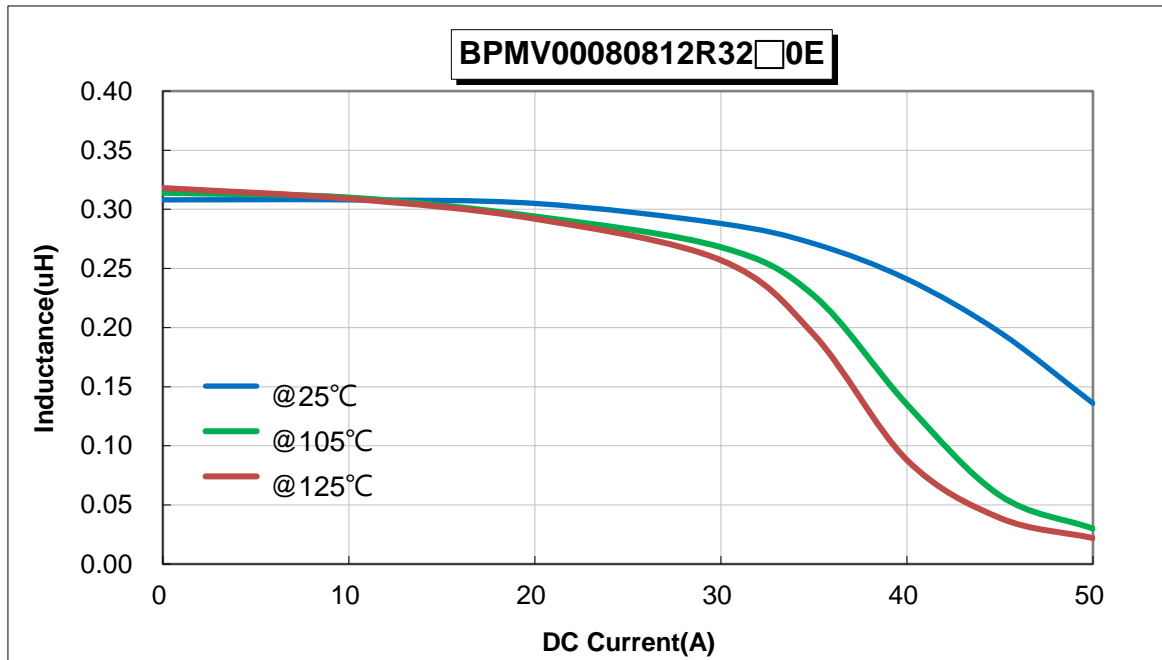

### TEMPERATURE vs. DC CURRENT

