

EMI Common Mode Choke



BPPM Series



Overview

An EMI common mode choke (CMC) for power lines is a passive component specifically designed to suppress electromagnetic interference (EMI) in power supply circuits. A full series of common mode choke is designed for excellent noise attenuation with compact sizing for use in wide range of applications. Both standard series and custom designs are available.

Benefits

1. For DC Power Line Common Mode Filter
2. Miniature SMD type common mode filter for fully automated assembly
3. Wide impedance range (70Ω ~ 3000Ω) for EMI suppression
4. Operating temperature range—40°C~125°C
4. Excellent solderability

Applications

1. Networking
2. EMI solutions for charger
3. Media player, Dashboard

Product Information

Series	Size Code (JIS/EIA)	Impedance(Ω)
BPPM	5050/2020 7060/2824 9070/3628 1211/4844 1513/6052 4850/1920	70 ~ 3000



BPPM00050520 Series Specification

1 Scope: This specification applies to the Pb Free DC Power Line Common Mode Filter

2 Part Numbering:

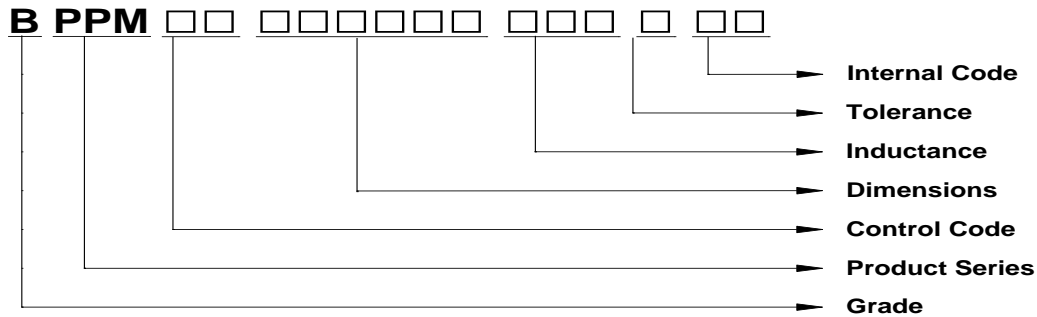

3 Rating:

Operating Temperature: - 40°C ~ 125°C(Including self - temperature rise)

Storage Temperature: (on tape & reel): -20°C to +40°C; 75% RH max.

4 Standard Testing Condition:

	Unless otherwise specified	In case of doubt
Temperature	Ordinary Temperature(15 to 35°C)	20 to 30°C
Humidity	Ordinary Humidity(25 to 85% RH)	50 to 80 %RH

5 Configuration and Dimensions and Unit Weight:

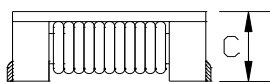
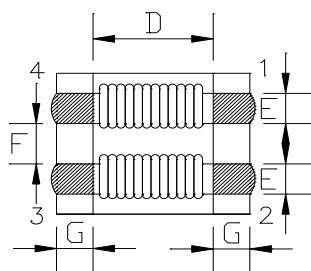
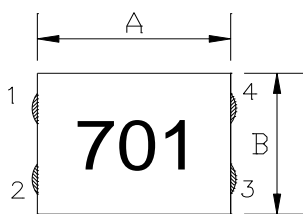

A:	4.7±0.5	mm
B:	4.5±0.5	mm
C:	2.0Max.	mm
D:	2.7Typ.	mm
E:	0.75Typ.	mm
F:	1.25Typ.	mm
G:	1.0Typ.	mm

Marking XXX

Marking color:Black

Net Weight (grms)

SIZE CODE	Net Weight (grms)
050520	0.12(Typ.)

BPPM00050520 Series Specification

6 Electrical Characteristics:

PT/NO.	Impedance(Ω) at 100MHz		Resistance RDC(m Ω) Max. (1 line)	Rated Current (A) Max.	Insulation Resistance (M Ω) Min.	Rated Voltage (V)Max.
	Min.	Typ.				
BPPM00050520301X0E	100	300	45	3.0	10	50
BPPM00050520401X0E	200	400	50	2.5	10	50
BPPM00050520501X0E	300	500	55	2.4	10	50
BPPM00050520701X0E	500	700	59	2.2	10	50
BPPM00050520102X0E	800	1000	68	2.1	10	50
BPPM00050520122X0E	1000	1200	74	2.0	10	50
BPPM00050520142X0E	1200	1400	81	1.9	10	50

CIRCUIT DIAGRAM



NOTE:

1. Rated DC Current : Based on temperature rise (ΔT : 40 $^{\circ}$ C Typ.)

BPPM00050520 Series Specification

6 Electrical Characteristics:

(6)-1 Impedance

Measured by HP4291B RF Impedance Analyzer.

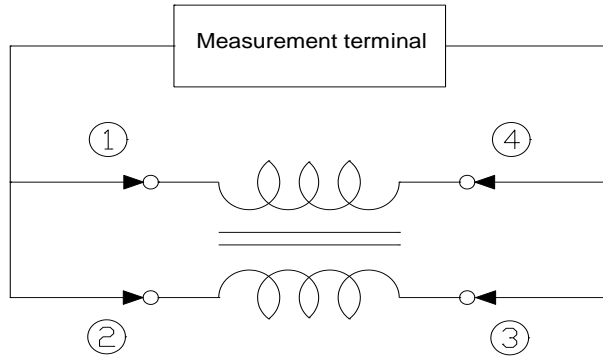

(6)-2 DC Resistance

Measured by Chroma 16502 milliohm meter.

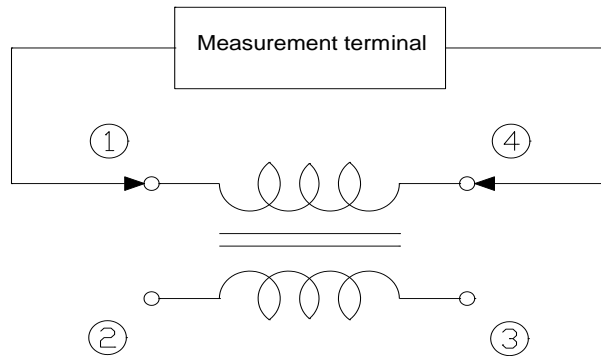

(6)-3 Insulation Resistance

Measured by Chroma 19073

Measurement voltage : 50V , Measurement time : 3 sec.

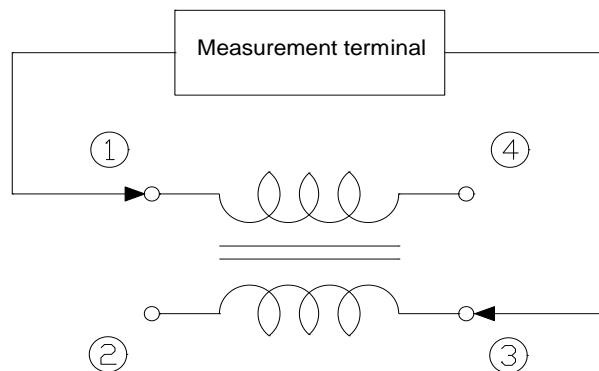

BPPM00050520 Series Specification

6.1 Construction:

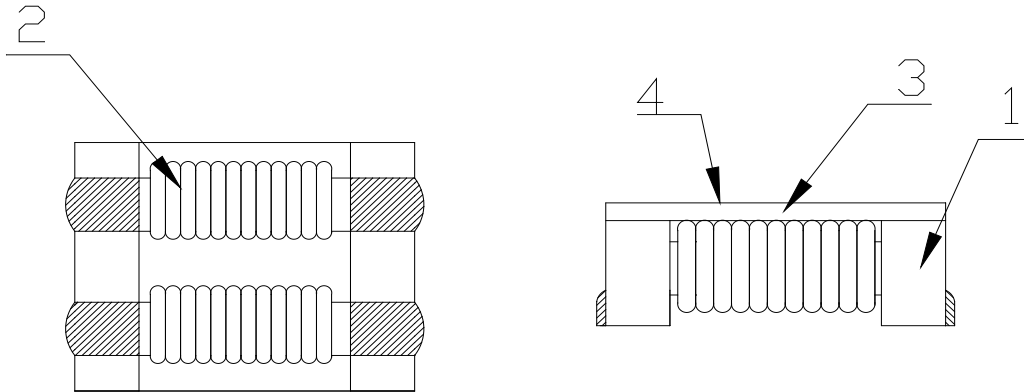

6.2 Material List:

NO.	ITEM	DESCRIPTION & TYPE
1	CORE	FERRITE
2	Wire	Magnet Wire
3	Cover	Mayler
4	Marking	INK

BPPM00050520 Series Specification

MECHANICAL

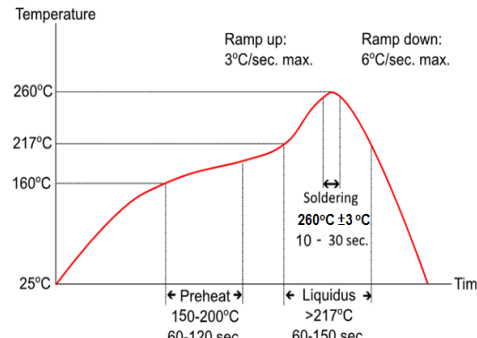
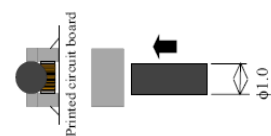
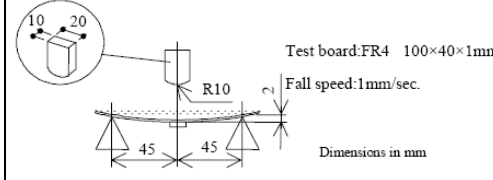
TEST ITEM	SPECIFICATION	TEST DETAILS
Solder ability	The product shall be connected to the test circuit board by the fillet (the height is 0.2mm).	Apply cream solder to the printed circuit board . Refer to clause 8 for Reflow profile.
Resistance to Soldering heat (reflow soldering)	There shall be no damage or problems.	<p>Temperature profile of reflow soldering</p>  <p>Note: 1. Re-Flow Possible times:within 2 times 2. Nitrogen adopted is recommended while in re-flow</p>
Terminal strength	The terminal electrode and the ferrite must not be damaged.	<p>Solder a chip to test substrate , and then laterally apply a load 9.8N in the arrow direction.</p> 
Strength on PC board bending	The terminal electrode and the ferrite must not be damaged.	<p>Solder a chip to test substrate and then apply a load.</p> 
High temperature resistance	<p>Impedance:Within±20% of the initial value.</p> <p>Insulation resistance and DC resistance on the specification(refer to clause 2-1) shall be met.</p> <p>The terminal electrode and the ferrite must not be damaged.</p>	<p>After the samples shall be soldered onto the test circuit board,the test shall be done.</p> <p>Measurement : After placing for 24 hours min.</p> <p>Temperature : +125±2°C</p> <p>Applied voltage : Rated voltage</p> <p>Applied current : Rated current</p> <p>Testing time : 500±12 hours</p>

BPPM00050520 Series Specification

MECHANICAL

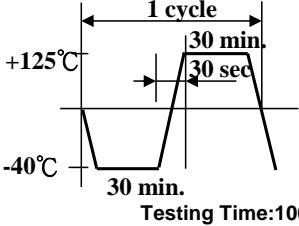
TEST ITEM	SPECIFICATION	TEST DETAILS
Humidity resistance	<p>Impedance: Within $\pm 20\%$ of the initial value.</p> <p>Insulation resistance and DC resistance on the specification (refer to clause 2-1) shall be met.</p> <p>The terminal electrode and the ferrite must not be damaged.</p>	<p>After the samples shall be soldered onto the test circuit board, the test shall be done.</p> <p>Measurement : After placing for 24 hours min.</p> <p>Temperature : $+60 \pm 2^\circ\text{C}$, Humidity : 90 to 95 %RH</p> <p>Applied voltage : Rated voltage</p> <p>Applied current : Rated current</p> <p>Testing time : 500 ± 12 hours</p>
Thermal shock	<p>Impedance: Within $\pm 20\%$ of the initial value.</p> <p>Insulation resistance and DC resistance on the specification (refer to clause 2-1) shall be met.</p> <p>The terminal electrode and the ferrite must not be damaged.</p>	 <p>Testing Time: 100 cycle</p>
Low temperature storage	<p>Impedance: Within $\pm 20\%$ of the initial value.</p> <p>Insulation resistance and DC resistance on the specification (refer to clause 2-1) shall be met.</p> <p>The terminal electrode and the ferrite must not be damaged.</p>	<p>After the samples shall be soldered onto the test circuit board, the test shall be done.</p> <p>Measurement : After placing for 24 hours min.</p> <p>Temperature : $-40 \pm 2^\circ\text{C}$</p> <p>Testing time : 500 ± 12 hours</p>
Vibration	<p>Impedance: Within $\pm 20\%$ of the initial value.</p> <p>Insulation resistance and DC resistance on the specification (refer to clause 2-1) shall be met.</p> <p>The terminal electrode and the ferrite must not be damaged.</p>	<p>After the samples shall be soldered onto the test circuit board, the test shall be done.</p> <p>Frequency : 10 to 55 Hz</p> <p>Amplitude : 1.52 mm</p> <p>Dimension and times : X , Y and Z directions for 2 hours each.</p>
Solderability	<p>New solder More than 75%</p>	<p>Flux (rosin, isopropyl alcohol (JIS-K-1522)) shall be coated over the whole of the sample before hard, the sample shall then be preheated for about 2 minutes in a temperature of $130 \sim 150^\circ\text{C}$ and after it has been immersed to a depth 0.5mm below for 3 ± 0.2 seconds fully in molten solder M705 with a temperature of $245 \pm 2^\circ\text{C}$. More than 75% of the electrode sections shall be covered with new solder smoothly when the sample is taken out of the solder bath.</p>

BPPM00050520 Series Specification

7 Packaging:

7.1 Packaging -Cover Tape

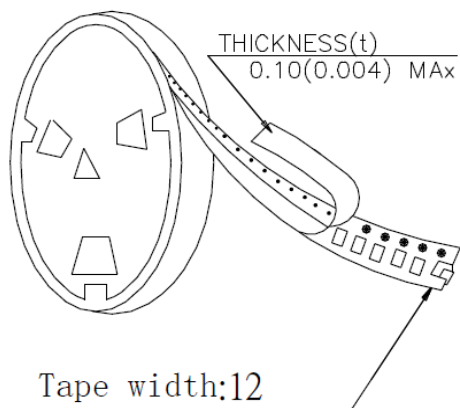

7.2 Packaging Quantity

TYPE	PCS/REEL
BPPM00050520	1000

7.3 Reel Dimensions

Unit : mm

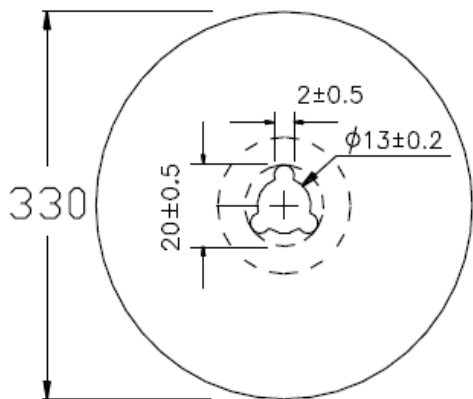

BPPM00050520 Series Specification

7 Packaging:

7.4 Tape Dimensions in mm

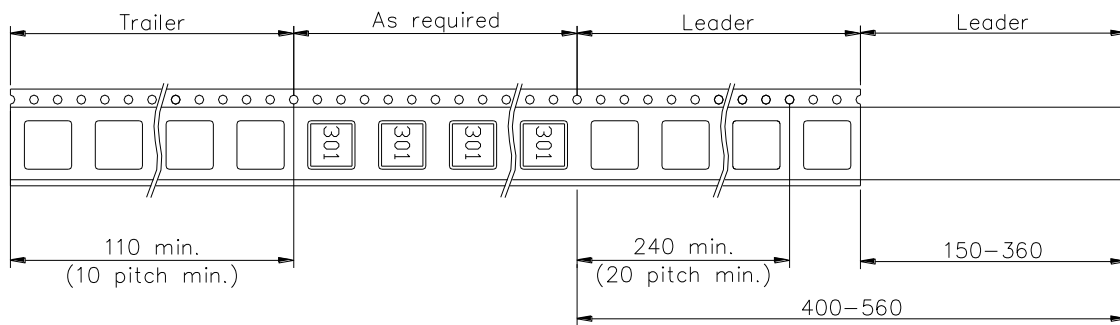
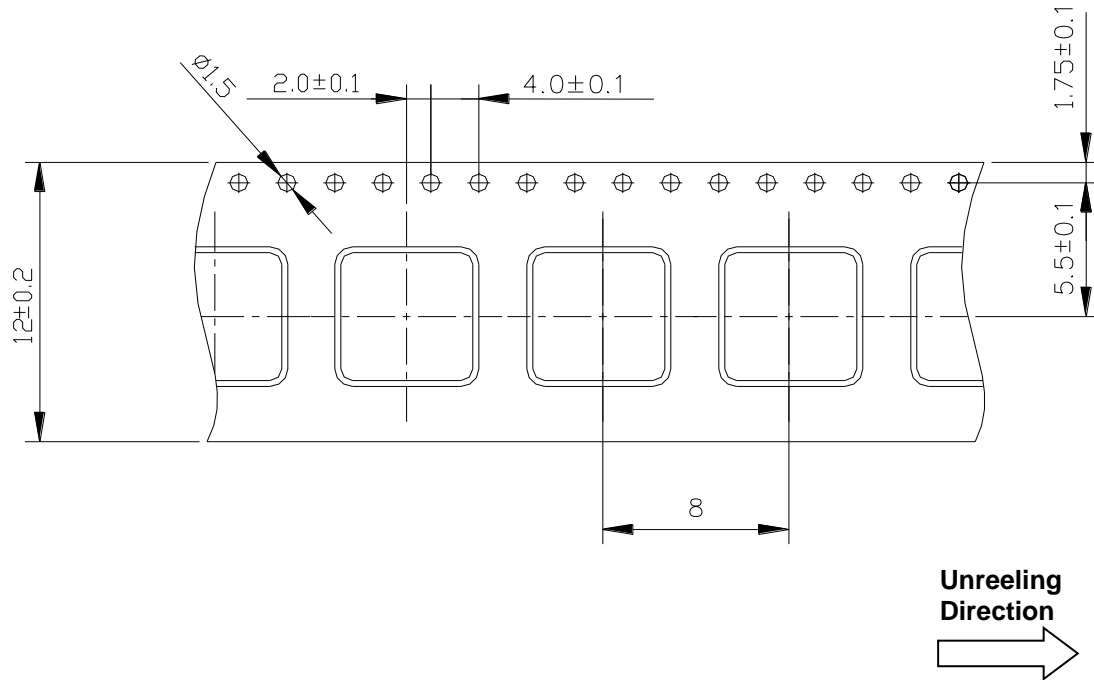

8 Recommended Land Pattern:

(STANDARD PATTERN) Unit : mm

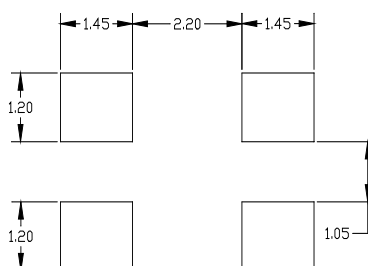

BPPM00050520 Series Specification

9 Note:

1. Please make sure that your product has been evaluated and confirmed against your specifications when our product is mounted to your product.
2. Do not knock or drop.
3. All the items and parameters in this product specification have been prescribed on the premise that our product is used for the purpose, under the condition and in the environment agreed upon between you and us. You are requested not to use our product deviating from such agreement.
4. Please keep the distance between transformer/coil and other components
(refer to the standard IEC 950)
5. The moisture sensitivity level (MSL) of products is classified as level 1.
6. Suggestion
On customer side this product series need to be fixed by the glue after IR reflow.
Please refer to below example photo:

BPPM00050520 Series Specification

TYPICAL ELECTRICAL CHARACTERISTICS

Frequency vs impedance

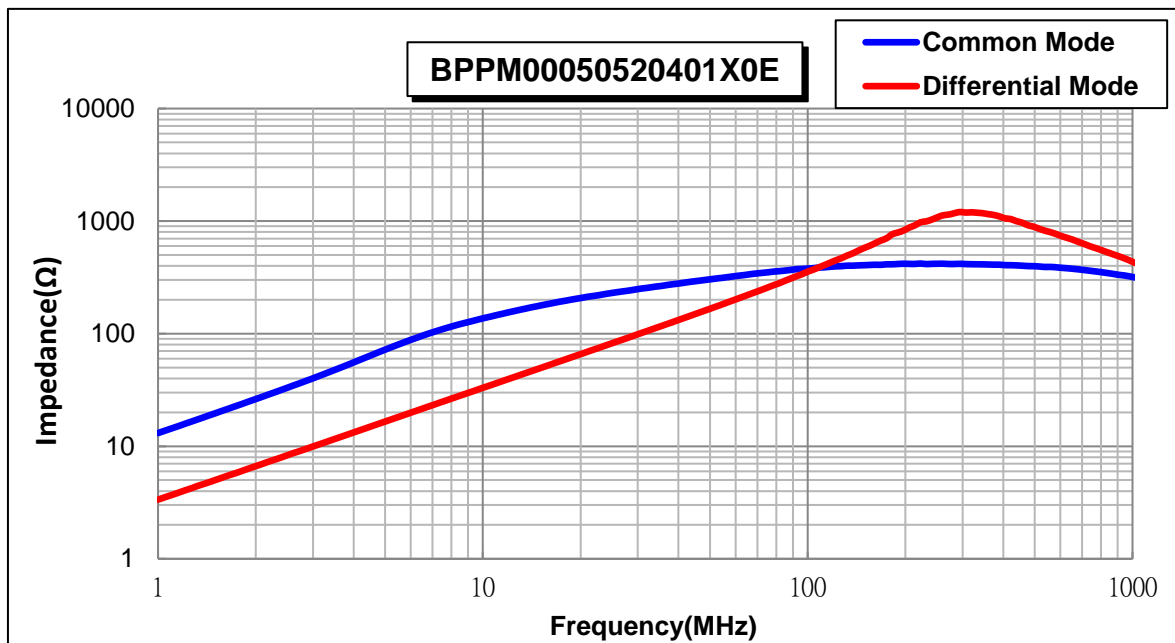
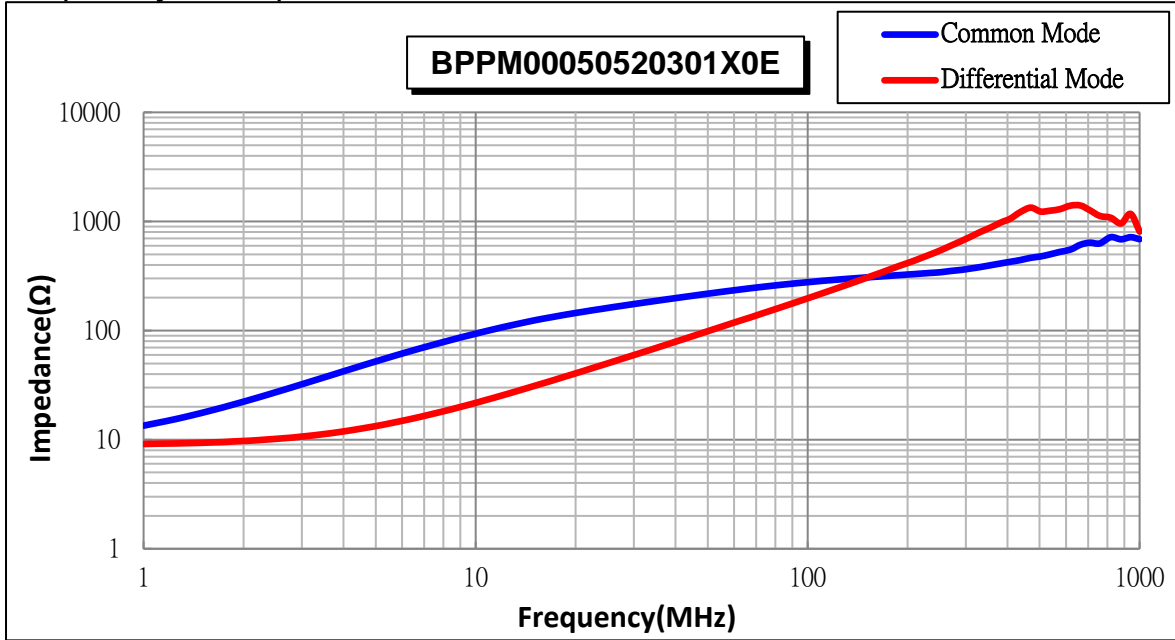

BPPM00050520 Series Specification

TYPICAL ELECTRICAL CHARACTERISTICS

Frequency vs impedance

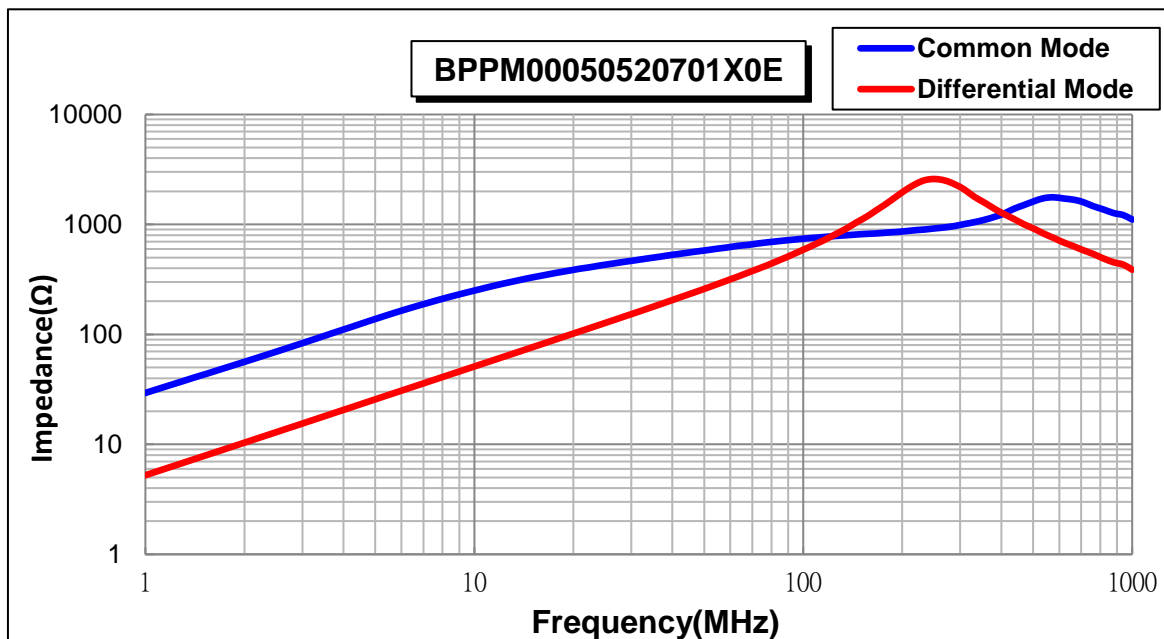
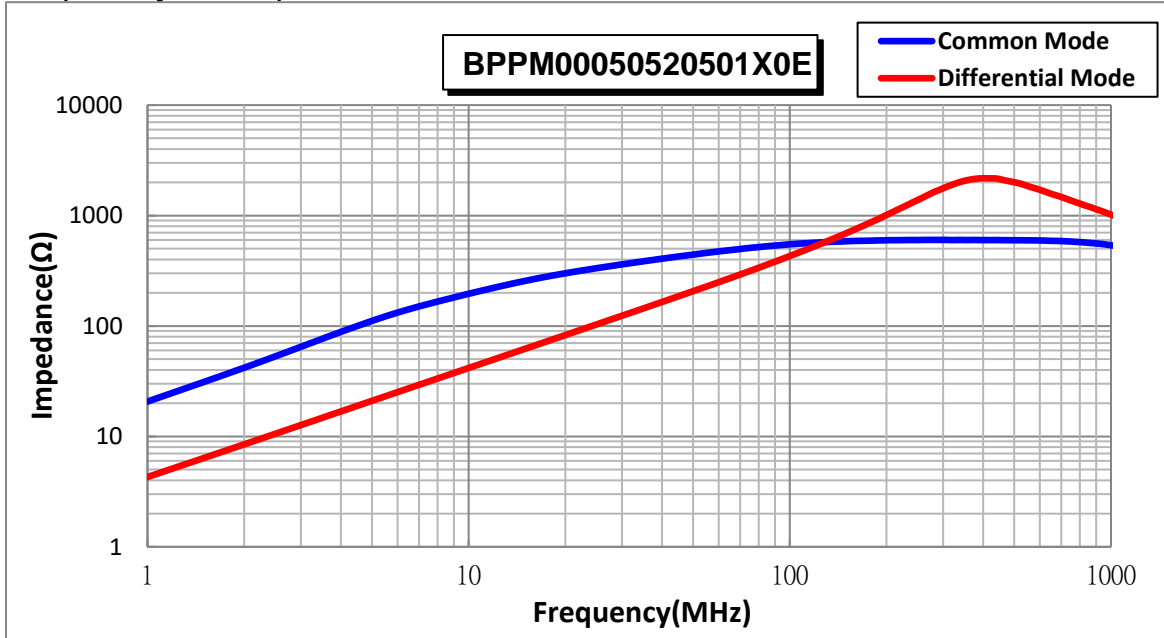

BPPM00050520 Series Specification

TYPICAL ELECTRICAL CHARACTERISTICS

Frequency vs impedance

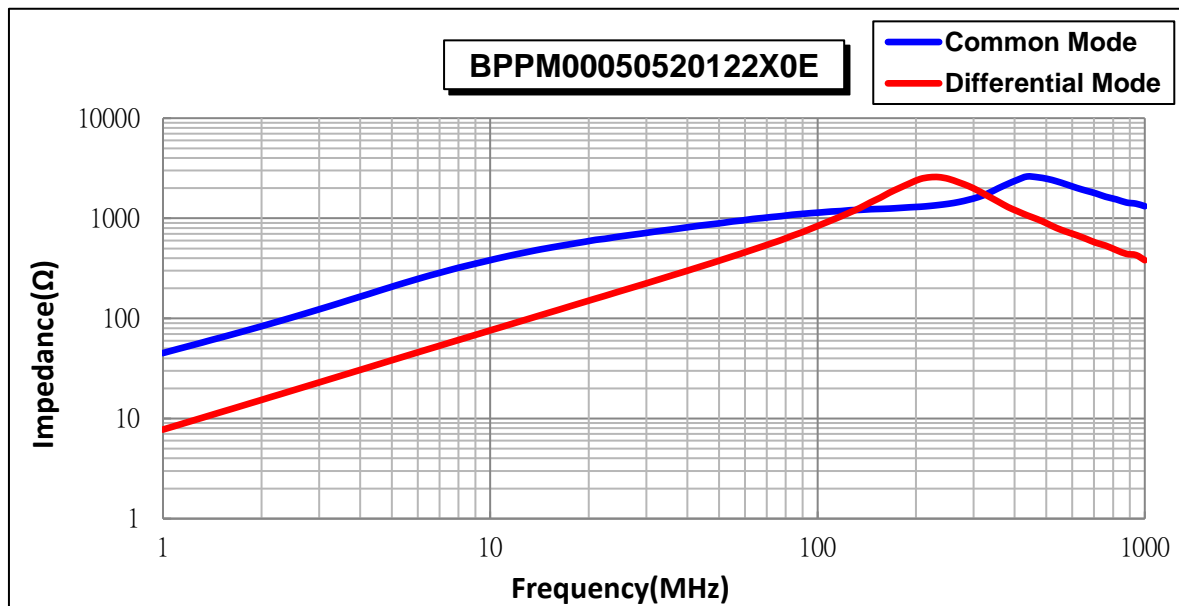
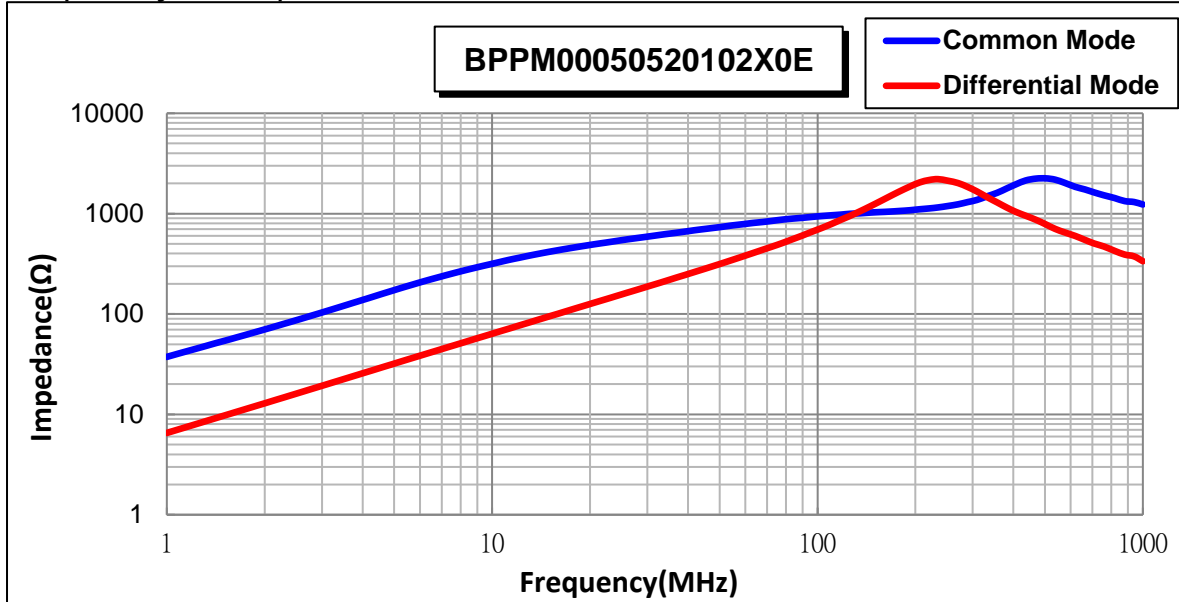

BPPM00050520 Series Specification

TYPICAL ELECTRICAL CHARACTERISTICS

Frequency vs impedance

