

Power Inductor



BPSC Series



Overview

Power inductors are passive electronic components used in various circuits to store energy in a magnetic field when electrical current flows through them. They are critical in filtering, energy storage, and noise suppression in power electronic systems. They are designed to handle higher currents and are optimized for minimal power loss and thermal efficiency.

Benefits

1. Ferrite SMD Shielded Type
2. No thermal aging

Applications

1. AP Routers, STBs
2. LCD TVs and monitors
3. Game consoles
4. LED lightings
5. DC/DC converters

Product Information

Series	L (mm)	W(mm)	T (mm)	Inductance (μH)
BPSC	3.2	3.2	1.55	0.47 ~ 3300
	3.2	3.2	2.0	
	4.0	4.0	1.2	
	4.0	4.0	1.8	
	4.0	4.0	3.0	
	4.7	4.7	2.0	
	4.7	4.7	3.0	
	4.7	4.7	4.0	
	5.7	5.7	2.0	
	5.7	5.7	3.0	
	6.7	6.7	3.0	
	7.3	7.3	3.4	
	7.0	7.0	4.0	
	7.3	7.3	4.5	
	8.3	8.3	4.5	
	10.3	10.5	3.1	
	10.3	10.5	4	
10.3	10.5	5.1		
12.5	12.5	4.5		
12.5	12.5	6		
12.5	12.5	8		
12.0	12.0	10.0		



BPSC00131360 Series Specification

1 Scope: This specification applies to SMD Shielded Power Inductors

2 Part Numbering:

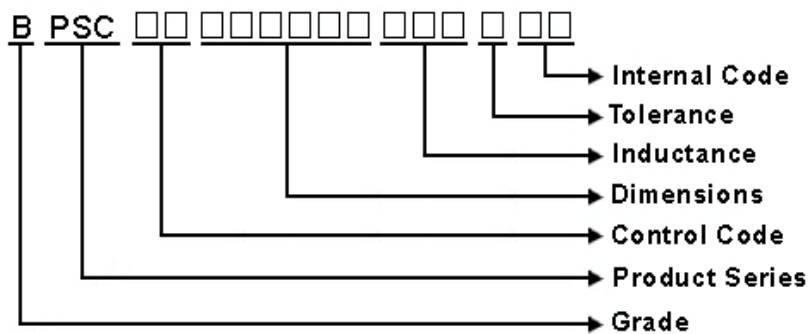

3 Rating:

Operating Temperature: - 40°C ~ + 125°C (Including self temp. rise)

Storage Temperature: - 40°C ~ + 125°C(For after the circuit board is mounted)

Storage Temperature: (on tape & reel): -20°C to +40°C; 75% RH max.

4 Marking:



Ex Marking: 100

Marking color : Black

5 Standard Testing Condition

	Unless otherwise specified	In case of doubt
Temperature	Ordinary Temperature(15 to 35°C)	20 to 30°C
Humidity	Ordinary Humidity(25 to 85% RH)	50 to 80 %RH

BPSC00131360 Series Specification

6 Configuration and Dimensions and Unit Weight:

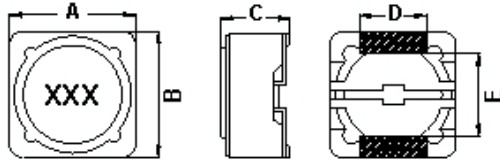

Dimensions in mm

TYPE	A	B	C	D	E
131360	12.5 Max.	12.5 Max.	6.0 Max.	5	7.6

Net Weight (grms)

SIZE CODE	Net Weight (grms)
131360	3.68(Typ.)

7 Electrical Characteristics:

Part No.	Inductance (uH)	Test Freq.	RDC (Ω)Max.	Isat(A) Max(Typ)	Irms (A)Typ.	Tolerance	Marking
BPSC001313603R3□00	3.3	1 kHz,1 V	0.015	8(11)	6.5	T	3R3
BPSC001313604R7□00	4.7	1 kHz,1 V	0.018	7.6(9.2)	5.7	M,T	4R7
BPSC001313606R4□00	6.4	1 kHz,1 V	0.018	6.4(8.1)	5.7	M,T	6R4
BPSC001313608R2□00	8.2	1 kHz,1 V	0.02	5.8(7.4)	5	M,T	8R2
BPSC00131360100□00	10	1 kHz,1 V	0.025	5.3(6.8)	4	M,T	100
BPSC00131360120□00	12	1 kHz,1 V	0.027	5.3(6.8)	3.5	M,T	120
BPSC00131360150□00	15	1 kHz,1 V	0.03	4.0(5.2)	3.3	M,T	150
BPSC00131360180□00	18	1 kHz,1 V	0.034	3.8(4.9)	3	M,T	180
BPSC00131360220□00	22	1 kHz,1 V	0.036	3.6(4.8)	2.8	M,T	220
BPSC00131360270□00	27	1 kHz,1 V	0.051	3.2(4.1)	2.3	M,T	270
BPSC00131360330□00	33	1 kHz,1 V	0.057	2.9(3.7)	2.1	M,T	330
BPSC00131360390□00	39	1 kHz,1 V	0.068	2.7(3.5)	2	M,T	390
BPSC00131360470□00	47	1 kHz,1 V	0.084	2.4(3.1)	1.9	M,T	470
BPSC00131360560□00	56	1 kHz,1 V	0.1	2.1(2.7)	1.7	M,T	560
BPSC00131360680□00	68	1 kHz,1 V	0.12	2.0(2.6)	1.5	M,T	680
BPSC00131360820□00	82	1 kHz,1 V	0.14	1.8(2.3)	1.4	M,T	820
BPSC00131360101□00	100	1 kHz,1 V	0.16	1.6(2.1)	1.3	M,T	101
BPSC00131360121□00	120	1 kHz,1 V	0.18	1.5(1.9)	1.05	M,T	121
BPSC00131360151□00	150	1 kHz,1 V	0.23	1.3(1.7)	1	M,T	151
BPSC00131360181□00	180	1 kHz,1 V	0.29	1.2(1.6)	0.9	M,T	181
BPSC00131360221□00	220	1 kHz,1 V	0.32	1.0(1.4)	0.85	M,T	221
BPSC00131360271□00	270	1 kHz,1 V	0.38	0.90(1.2)	0.83	M,T	271
BPSC00131360331□00	330	1 kHz,1 V	0.48	0.75(1.1)	0.73	M,T	331
BPSC00131360391□00	390	1 kHz,1 V	0.6	0.70(1.0)	0.67	M,T	391
BPSC00131360471□00	470	1 kHz,1 V	0.7	0.65(0.99)	0.66	M,T	471
BPSC00131360561□00	560	1 kHz,1 V	0.86	0.60(0.91)	0.54	M,T	561
BPSC00131360681□00	680	1 kHz,1 V	1.1	0.55(0.82)	0.52	M,T	681
BPSC00131360821□00	820	1 kHz,1 V	1.34	0.50(0.71)	0.43	M,T	821
BPSC00131360102□00	1000	1 kHz,1 V	1.53	0.45(0.64)	0.3	M,T	102

NOTE: □-tolerance M=±20%

1. Operating temperature range - 4 0 °C ~ 1 2 5 °C(Including self - temperature rise)

2. Isat for Inductance drop 35% from its value without current.

3. Irms for a 40 °C temperature rise from 25 °C ambient.

BPSC00131360 Series Specification

8 BPSC00131360 Series

8.1 Construction:

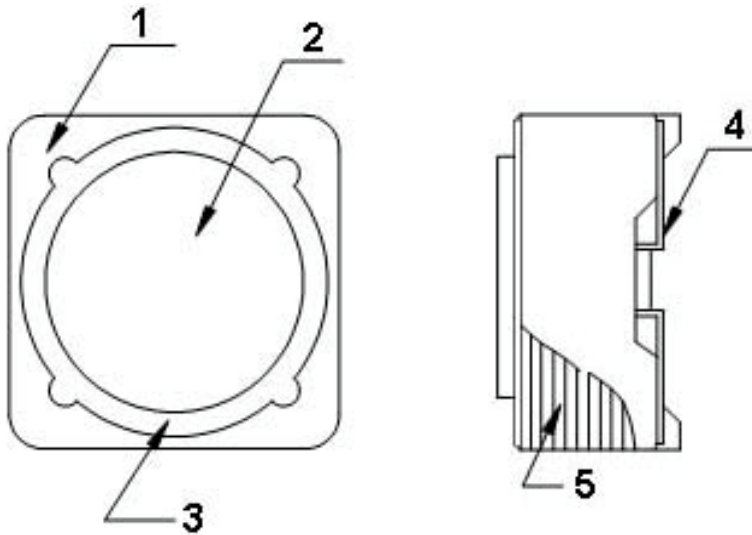

8.2 Material List:

No	Part	Material
1	CORE	FERRITE
2	CORE	FERRITE
3	EPOXY	
4	TERMINAL	TERMINAL COPPER
5	WIRE	MAGNET WIRE

BPSC00131360 Series Specification

9 Reliability Of Ferrite Wire Wound Power Inductor

1-1.Mechanical Performance

No	Item	Specification	Test Method
1-1-1	Vibration	Appearance: No damage Inductance: within $\pm 10\%$ of initial value	Test device shall be soldered on the substrate Oscillation Frequency: 10 to 55 to 10Hz for 1min Amplitude: 1.5mm Time: 2hrs for each axis (X, Y & Z), total 6hrs
1-1-2	Resistance to Soldering Heat	Appearance: No damage	Pre-heating: 150°C, 1min Solder Composition: Sn/Ag3.0/Cu0.5 Solder Temperature: 260 \pm 5°C Immersion Time: 10 \pm 1sec
1-1-3	Solder ability	The electrodes shall be at least 95% covered with new solder coating	Pre-heating: 150°C, 1min Solder Composition: Sn/Ag3.0/Cu0.5 Solder Temperature: 245 \pm 5°C Immersion Time: 4 \pm 1sec
1-1-4	Resistance to solvent	There must be no change in appearance or obliteration of marking.	Inductors must withstand 6 minutes of alcohol or water.

1-2.Environmental Performance

No	Item	Specification	Test Method															
1-2-1	Temperature Shock	Appearance: No damage Inductance: within $\pm 10\%$ of initial value	10 cycles (Air to Air) 1 cycles shall consist of: 30 minutes exposure to -55 °C 30 minutes exposure to 125 °C 15 seconds maximum transition between temperatures															
1-2-2	Temperature Cycle		One cycle: <table border="1"> <thead> <tr> <th>Step</th> <th>Temperature (°C)</th> <th>Time (min)</th> </tr> </thead> <tbody> <tr> <td>1</td> <td>-40\pm3</td> <td>30</td> </tr> <tr> <td>2</td> <td>25\pm2</td> <td>3</td> </tr> <tr> <td>3</td> <td>125\pm3</td> <td>30</td> </tr> <tr> <td>4</td> <td>25\pm2</td> <td>3</td> </tr> </tbody> </table>	Step	Temperature (°C)	Time (min)	1	-40 \pm 3	30	2	25 \pm 2	3	3	125 \pm 3	30	4	25 \pm 2	3
Step	Temperature (°C)		Time (min)															
1	-40 \pm 3		30															
2	25 \pm 2		3															
3	125 \pm 3	30																
4	25 \pm 2	3																
1-2-3	Humidity Resistance	Temperature: 40 \pm 2°C Relative Humidity: 90 ~ 95% Time: 1000hrs Measured after exposure in the room condition for 24hrs																
1-2-4	Heat Life	Temperature: 85 \pm 3°C Applied Current: Rated Current Time: 1000hrs Measured after exposure in the room condition for 24hrs																
1-2-5	Cold Resistance	Temperature: -40 \pm 3°C Time: 1000hrs Measured after exposure in the room condition for 24hrs																

BPSC00131360 Series Specification

Reflow Soldering Profile

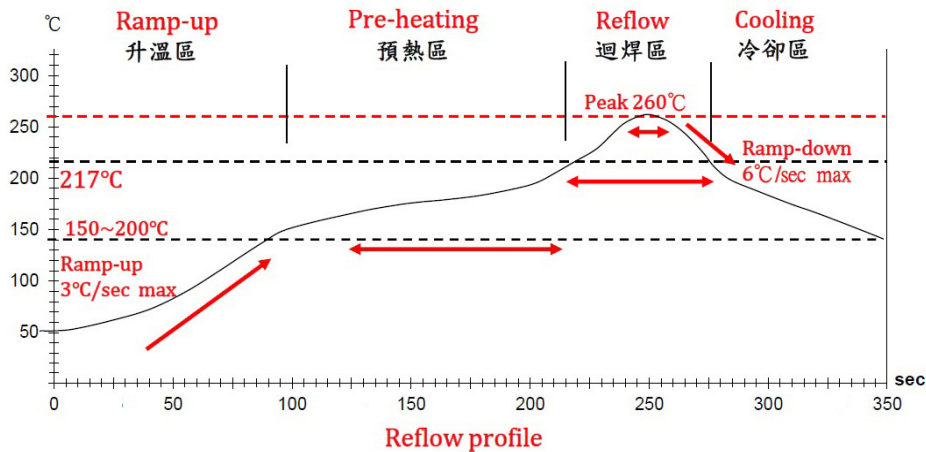

Lead-Free(LF)標準溫度分析範圍

Refer to J-STD-020C

管制項目 Item.	升温區 Ramp-up	預熱區 Pre-heating	迴焊區 Reflow	Peak Temp	冷卻區 Cooling
溫度範圍 Temp.scope	R.T ~ 150°C	150°C ~ 200°C	217°C	260±5°C	Peak Temp.~150°C
標準時間 Time spec.	-	60 ~ 180 sec	60 ~ 150 sec	20 ~ 40 sec	-
實際時間 Time result	-	75 ~ 100 sec	90 ~ 120 sec	20 ~ 35 sec	-

BPSC00131360 Series Specification

10 Packaging:

10.1 Packaging -Cover Tape

The force for tearing off cover tape is 10 to 130 grams in the arrow direction.

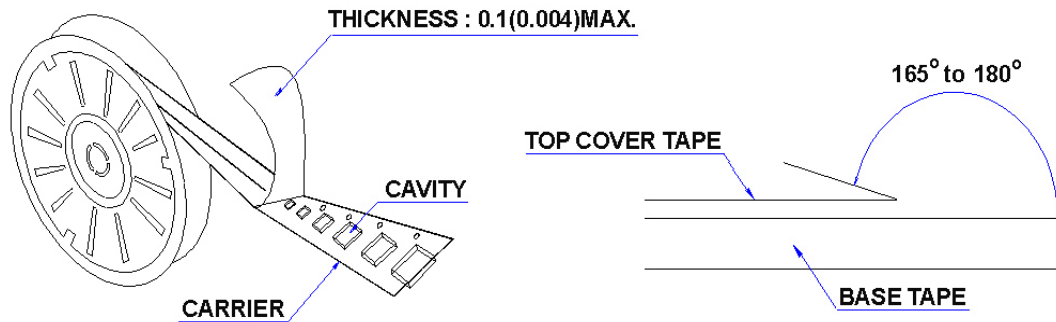

10.2 Packaging Quantity

TYPE	PCS/REEL
131360	600

10.3 Reel Dimensions

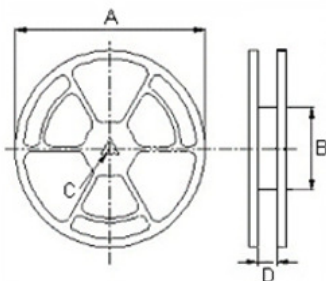

Dimensions in mm

TYPE	A	B	C	D
131360	330	100	13	24.4

BPSC00131360 Series Specification

10 Packaging:

10.4 Tape Dimensions in mm

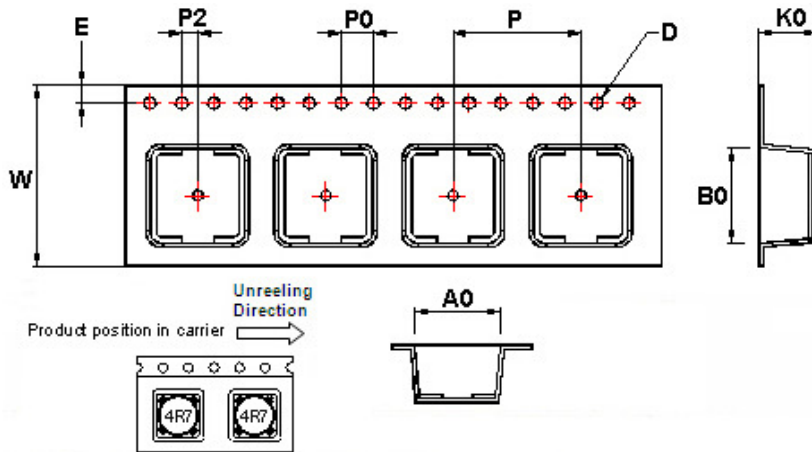

TYPE	A0	B0	K0	D	E	W	P	P0	P2
131360	12.6	12.6	6.7	1.55	1.75	24	16	4	2

11 Recommended Land Pattern:

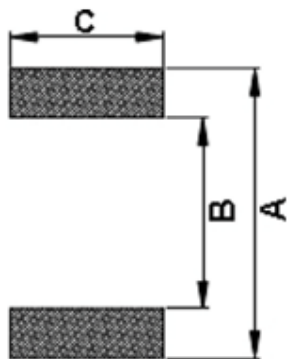

Dimensions in mm

TYPE	A	B	C
131360	13	7	5.4

12 Note:

1. Please make sure that your product has been evaluated and confirmed against your specifications when our product is mounted to your product.
2. Do not knock nor drop.
3. All the items and parameters in this product specification have been prescribed on the premise that our product is used for the purpose, under the condition and in the environment agreed upon between you and us. You are requested not to use our product deviating from such agreement.
4. Please keep the distance between transformer/coil and other components (refer to the standard IEC 950)
5. The moisture sensitivity level (MSL) of products is classified as level 1.

BPSC00131360 Series Specification

13 Graph:

BPSC001313603R3□00

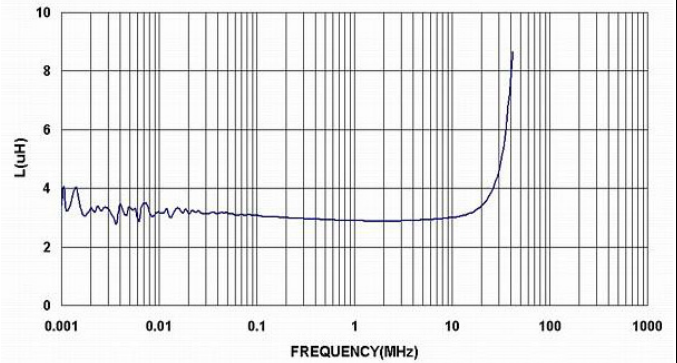
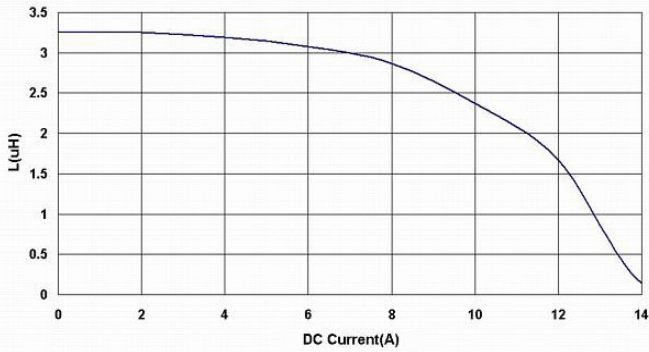

BPSC001313604R7□00

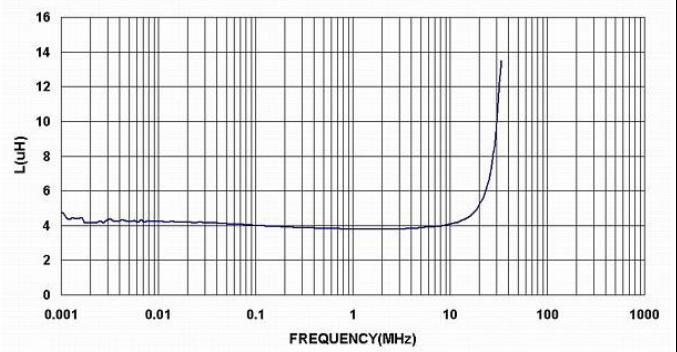
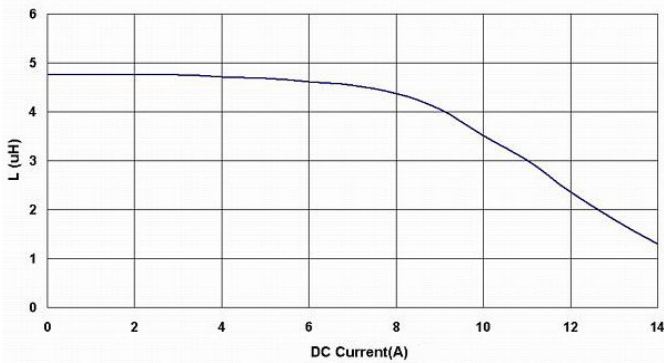

BPSC001313606R4□00

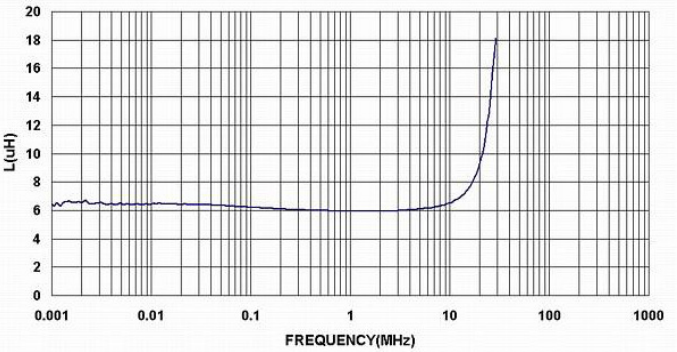
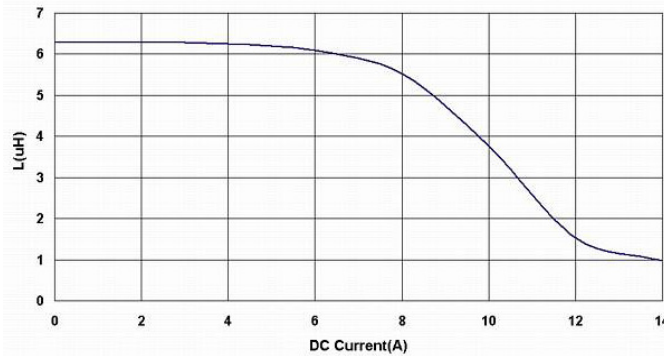

BPSC001313608R2□00

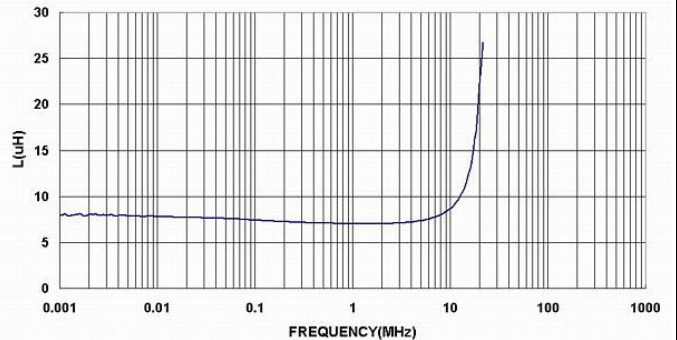
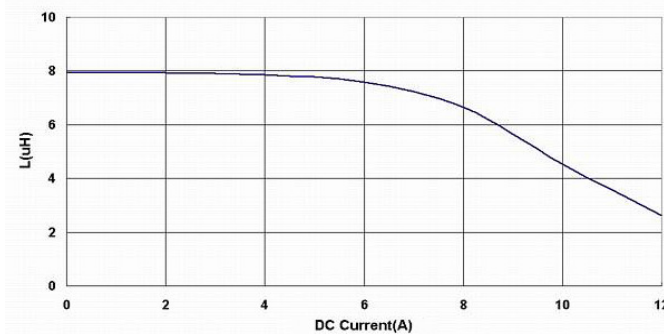

BPSC00131360 Series Specification

13 Graph:

BPSC00131360100□00

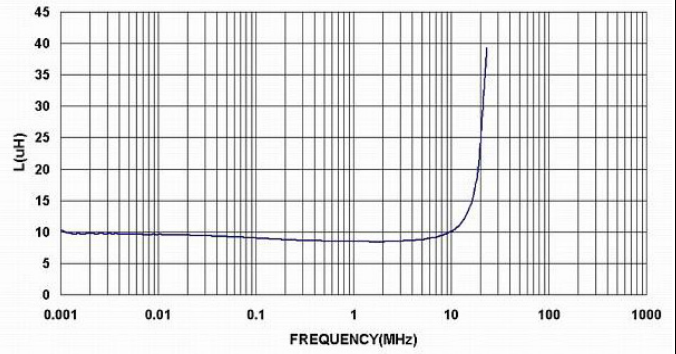

BPSC00131360120□00

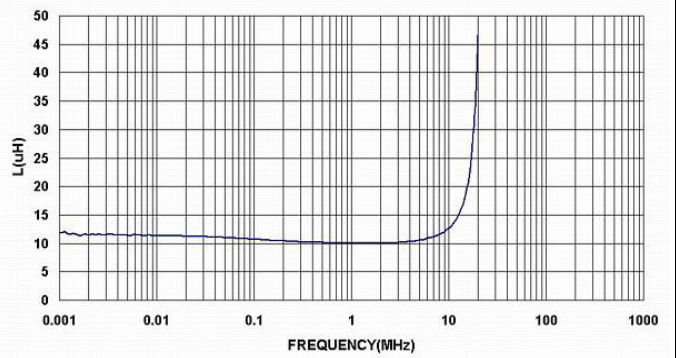
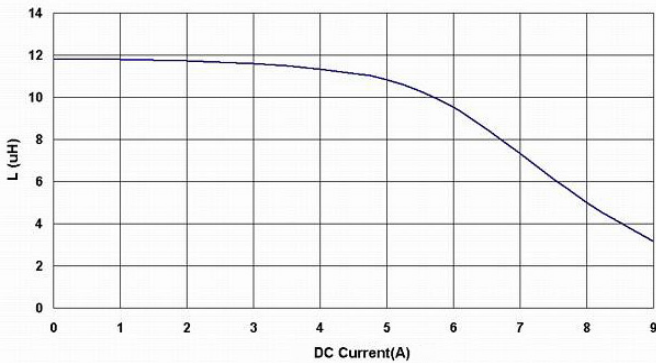

BPSC00131360150□00

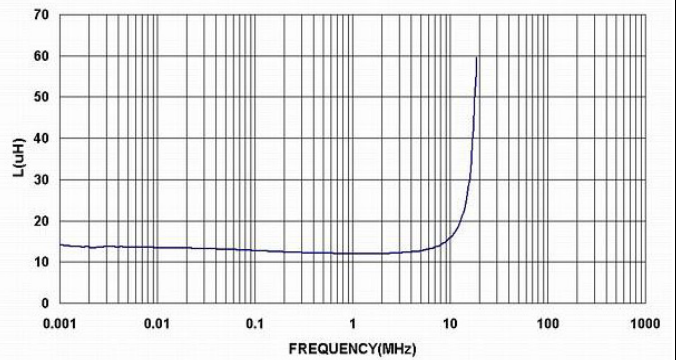
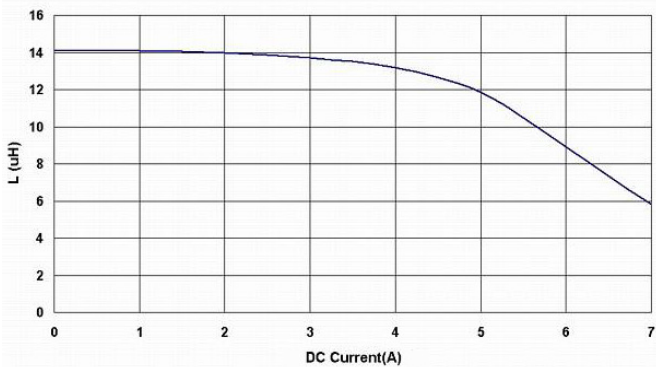

BPSC00131360180□00

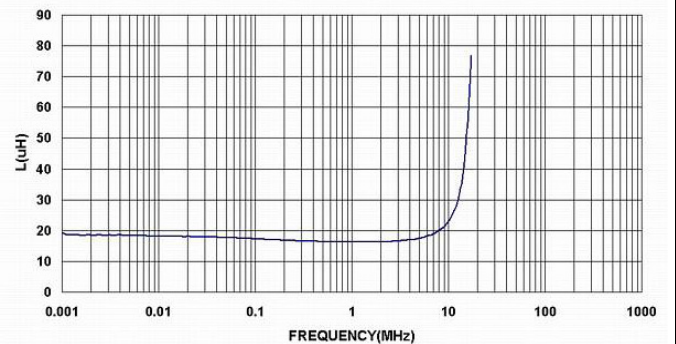
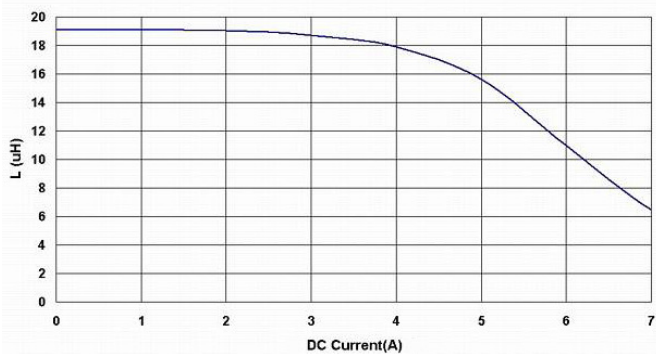

BPSC00131360 Series Specification

13 Graph:

BPSC00131360220□00

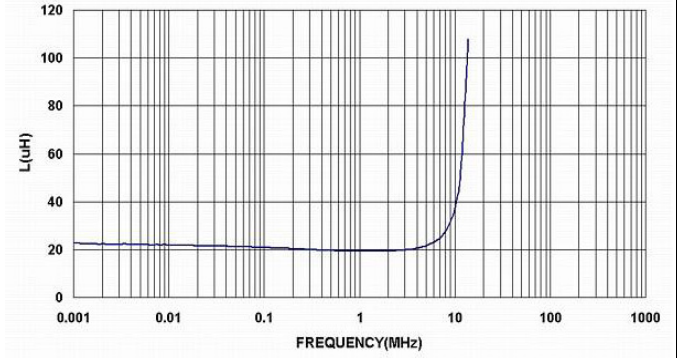
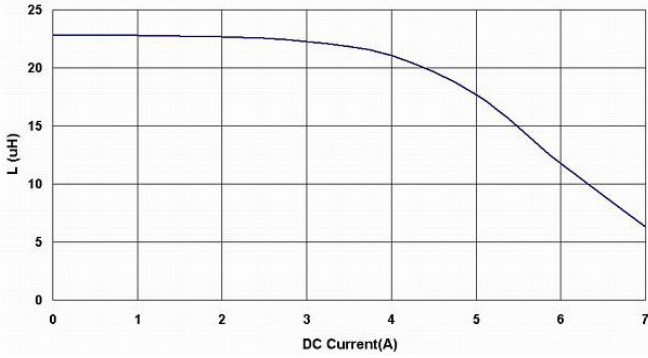

BPSC00131360270□00

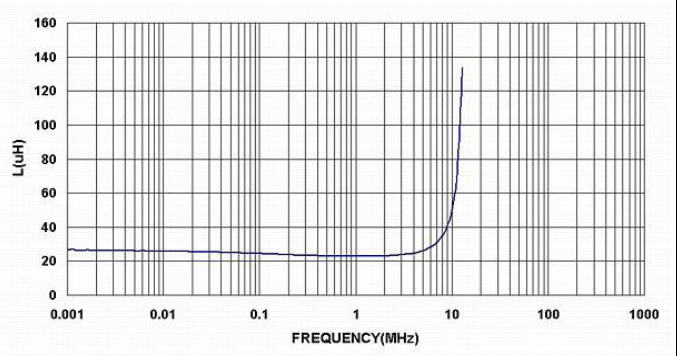
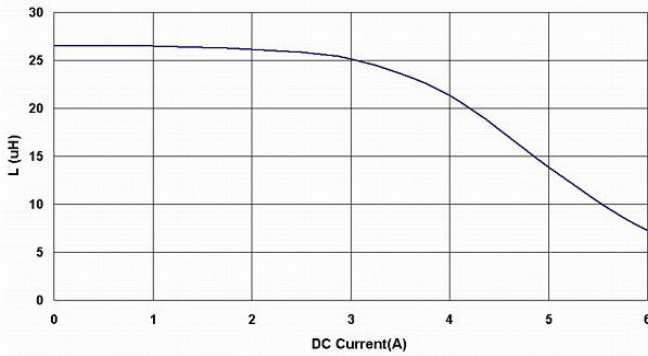

BPSC00131360330□00

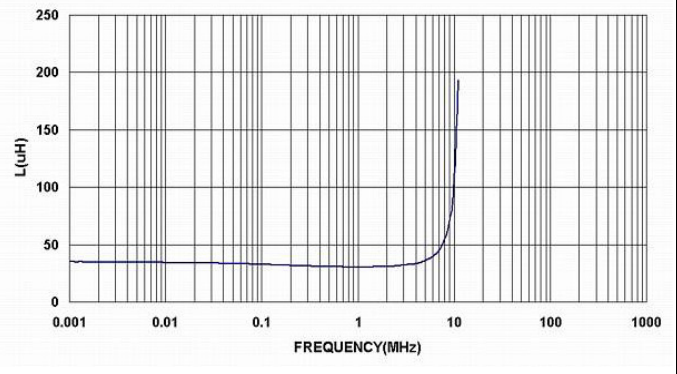

BPSC00131360390□00

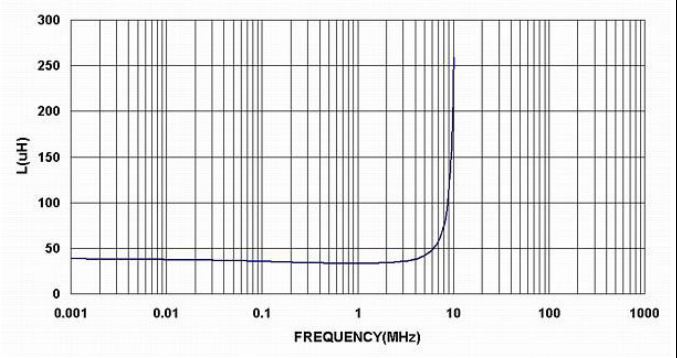
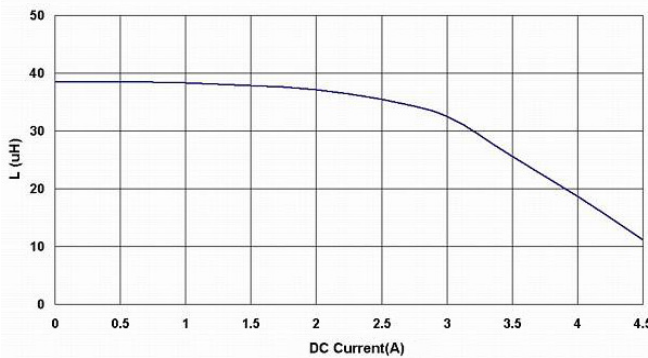

BPSC00131360 Series Specification

13 Graph:

BPSC00131360470□00

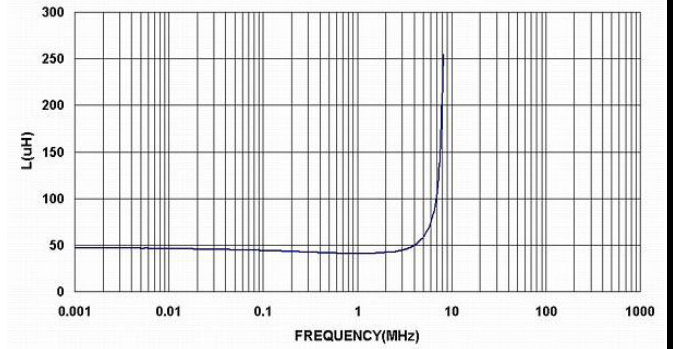
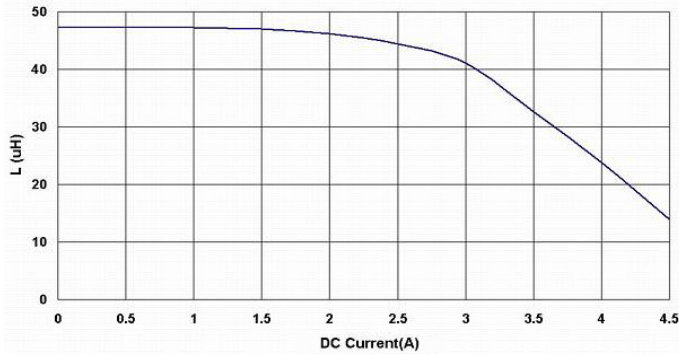

BPSC00131360560□00

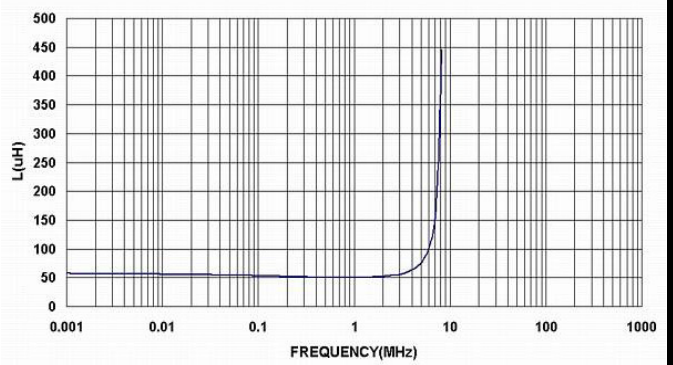
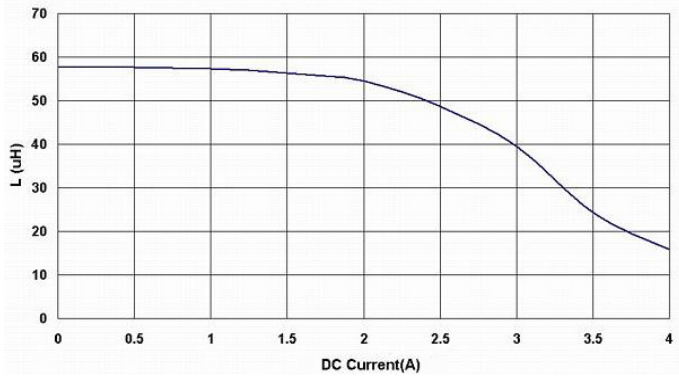

BPSC00131360680□00

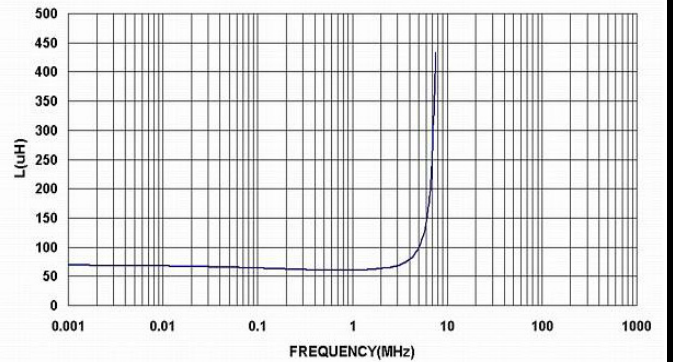
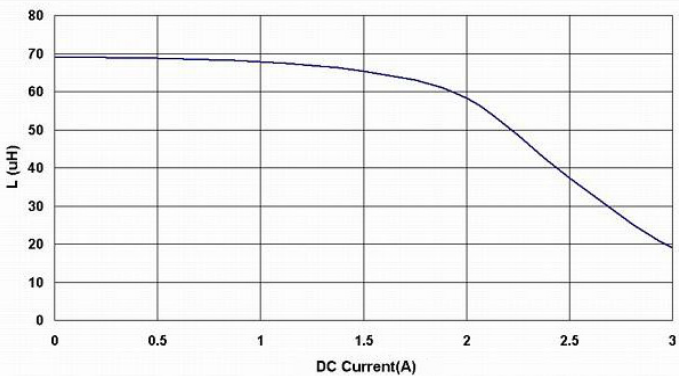

BPSC00131360820□00

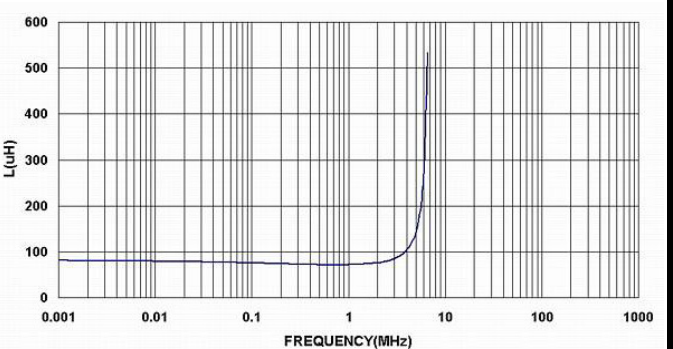
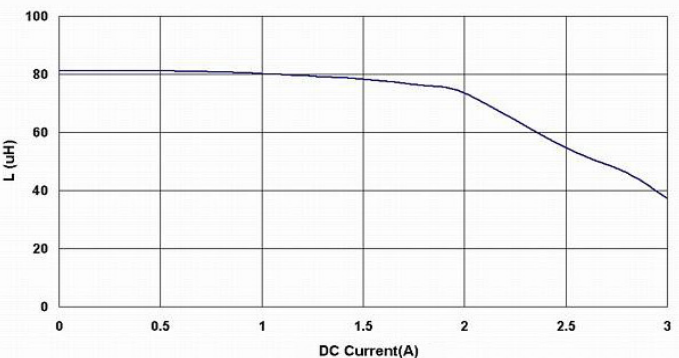

BPSC00131360 Series Specification

13 Graph:

BPSC00131360101□00

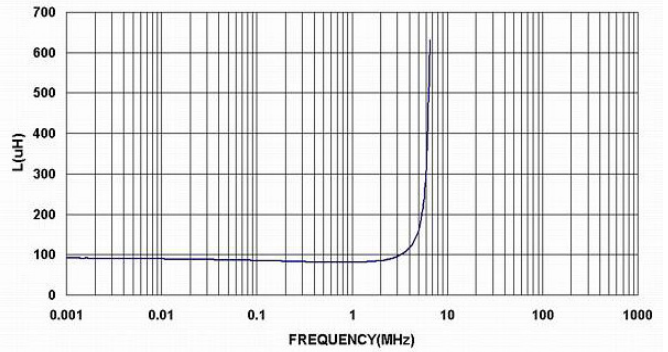
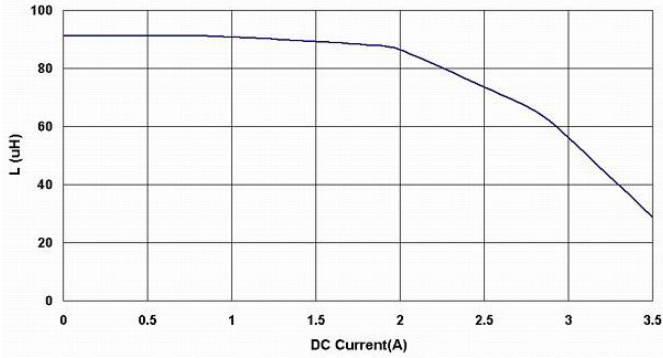

BPSC00131360121□00

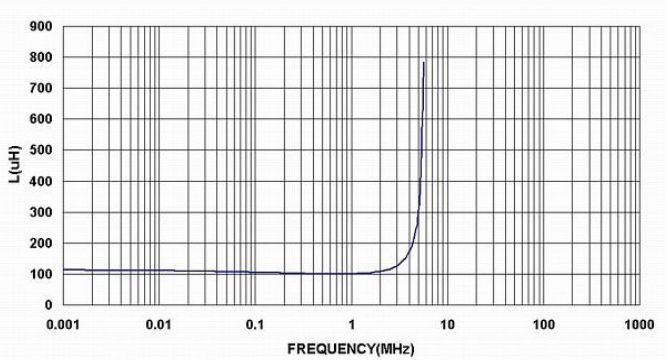
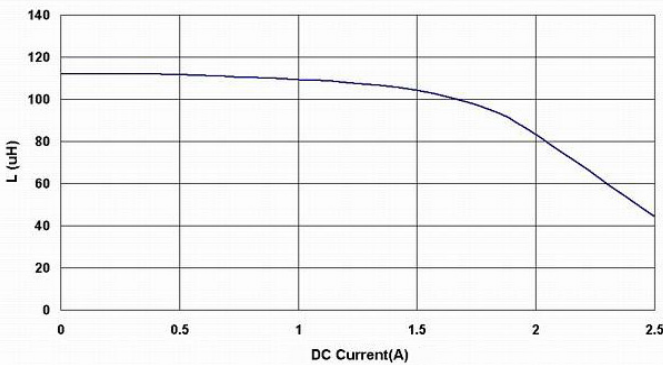

BPSC00131360151□00

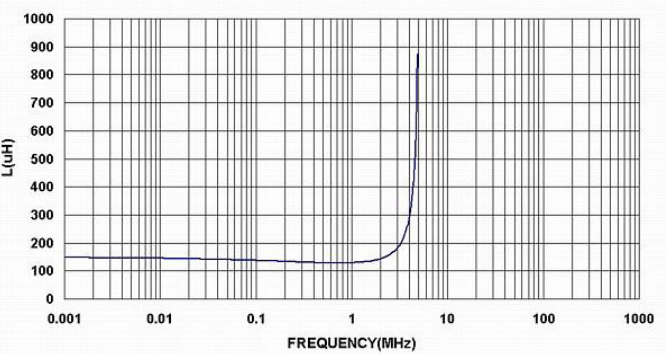
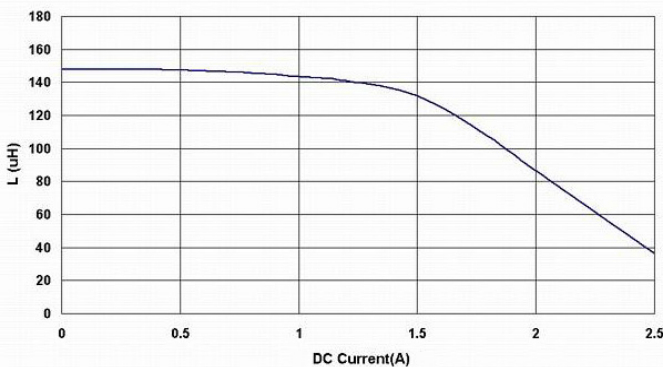

BPSC00131360181□00

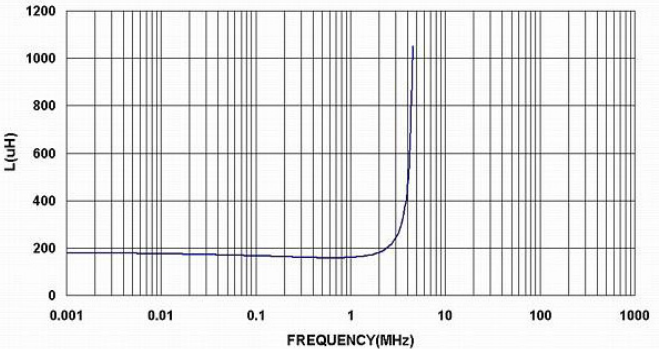
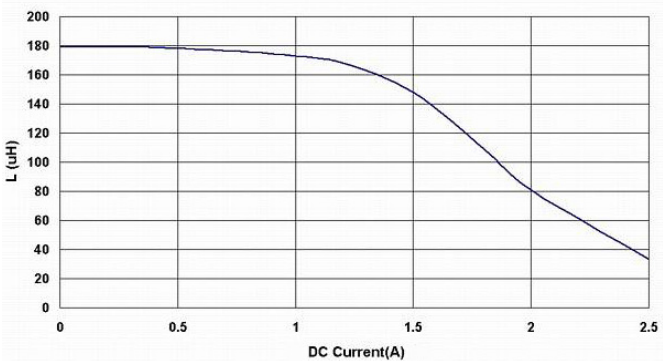

BPSC00131360 Series Specification

13 Graph:

BPSC00131360221□00

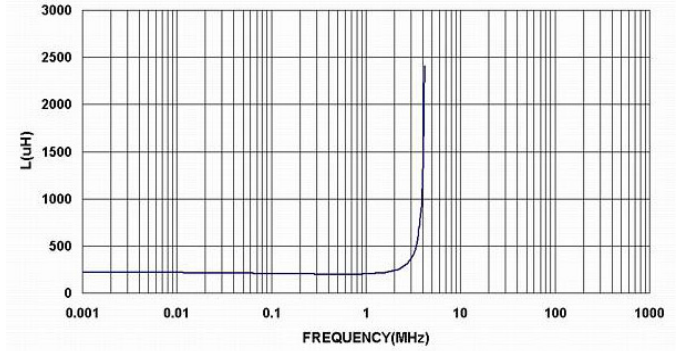
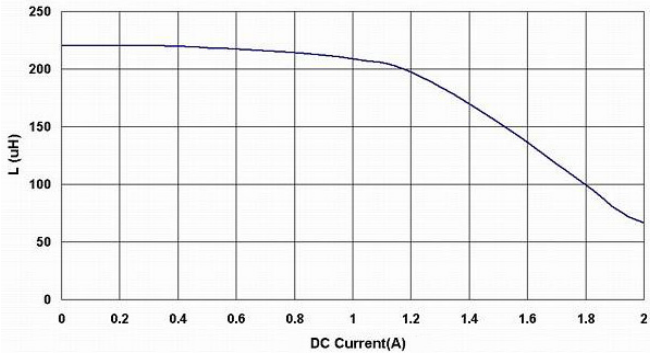

BPSC00131360271□00

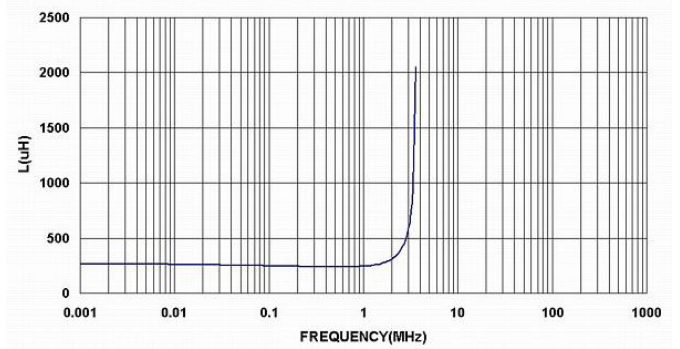
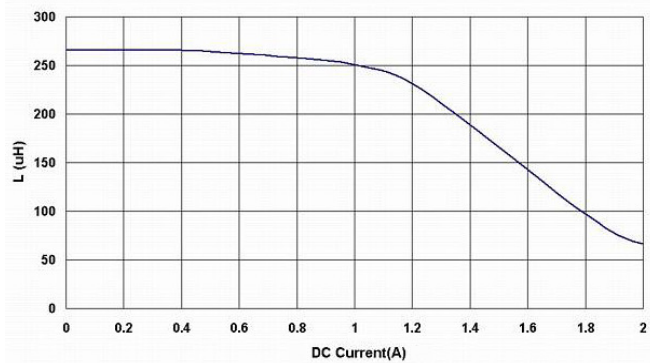

BPSC00131360331□00

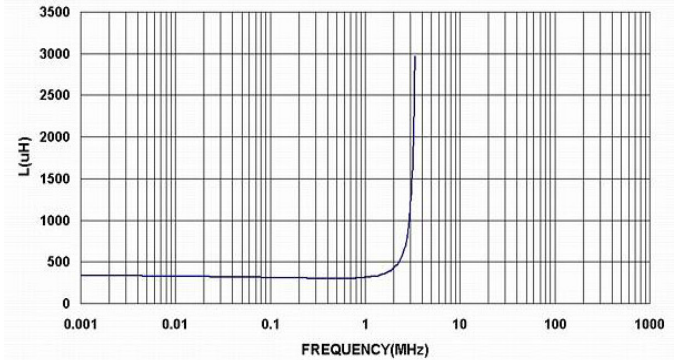
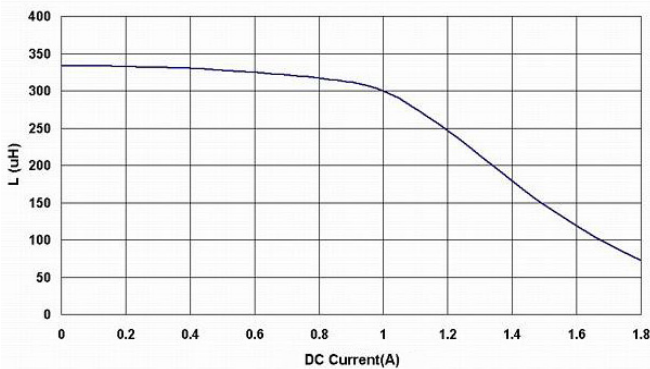

BPSC00131360391□00

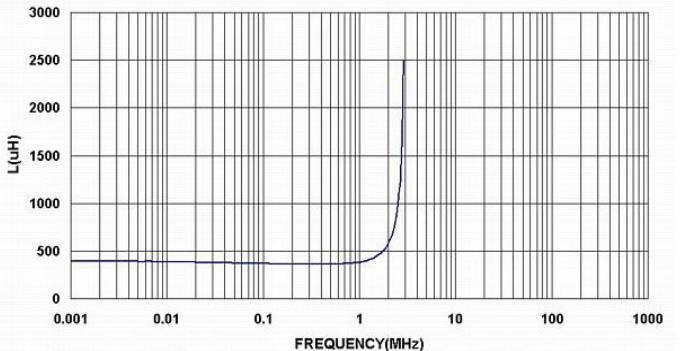
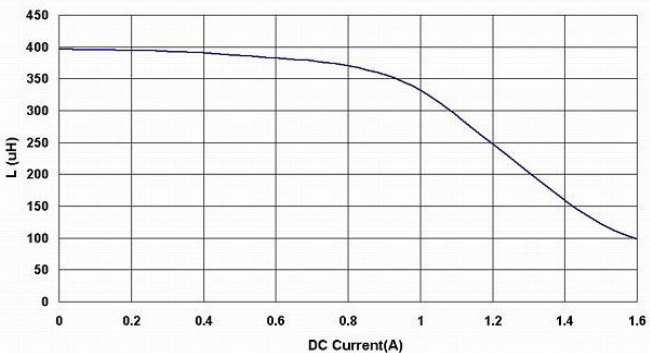

BPSC00131360 Series Specification

13 Graph:

BPSC00131360471□00

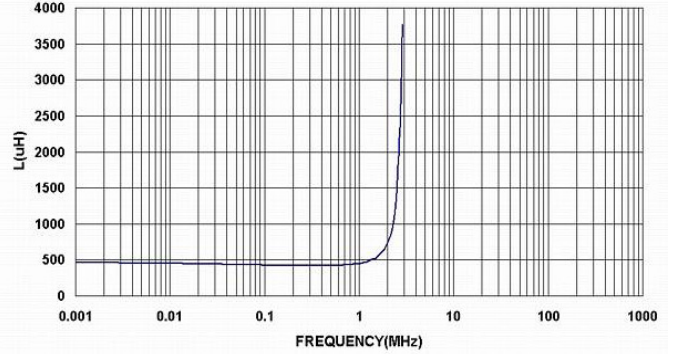
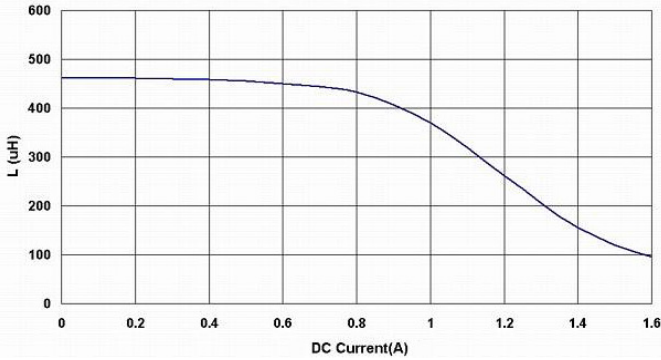

BPSC00131360561□00

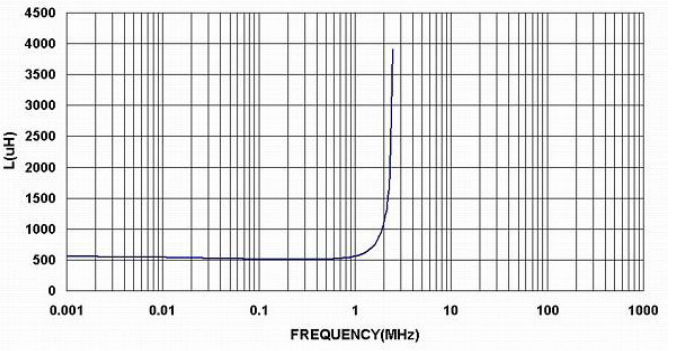
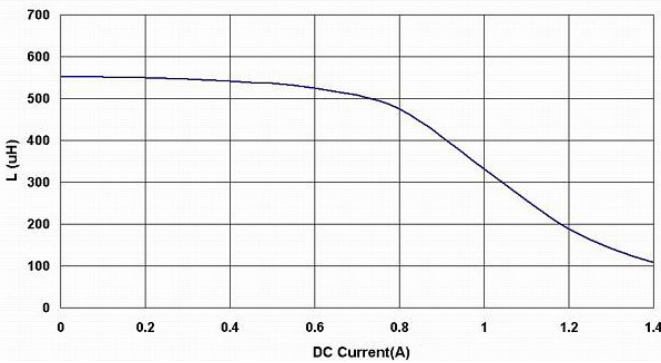

BPSC00131360681□00

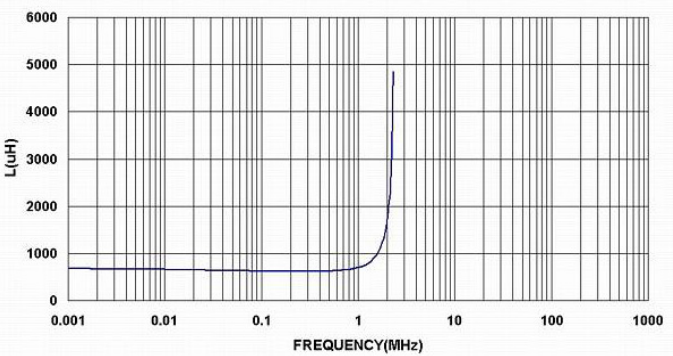
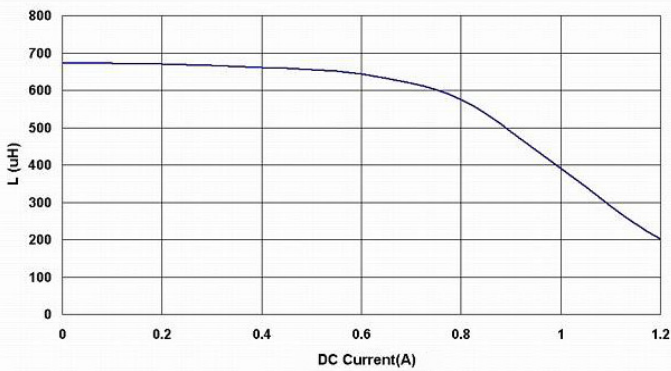

BPSC00131360821□00

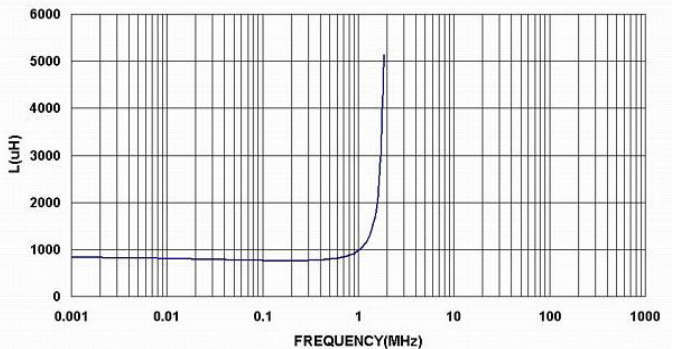
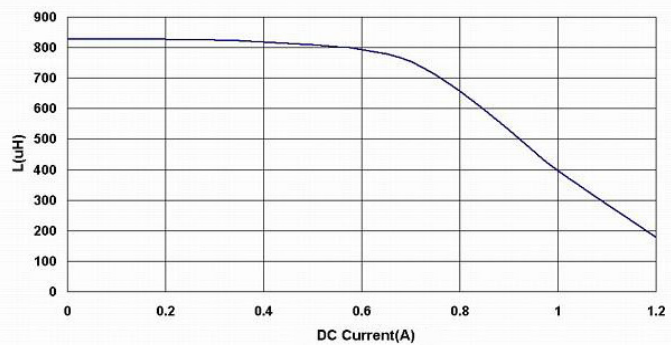

BPSC00131360 Series Specification

13 Graph:

BPSC00131360102□00

