

Z-BLOCKER® Z-350UK xDSL over POTS In-Line Filter

Description

The Z-350UK is an attractive customer premises equipment filter designed to expedite the service delivery and improve the performance of DSL services over plain old telephone service (POTS) in the United Kingdom. The Z-350UK filters all telephones, facsimile (fax) machines, answering machines, and other telephone equipment. Its filter design electronically isolates the high-speed DSL data stream from the voice-band equipment to provide premium voice quality and optimal DSL data rates.

Features

- Isolates telephone equipment impedances from DSL
- Protects voice-band equipment from high frequency DSL signals
- Compatible with all major DSL standards including ADSL, ADSL2+, VDSL, and VDSL2
- Compatible with Calling Line Identification (CLI) service, facsimile and metallic loop testing
- BT approved
- CE certified
- RoHS and WEEE compliant



Z-350UK filter provides a DSL convenience jack for connecting a DSL modem

Applications

The DSL user installs the Z-350UK filter into every telephone jack in the subscribers' premises that contains voice-band equipment devices such as cordless telephones, answering machines, fax machines, dial-up modems, and television set-top boxes.

The Z-350UK is one of many filters and splitters manufactured by Excelsus for subscriber-installed digital services within homes, offices, and hotels. Excelsus is the number one selling brand of DSL filters worldwide.

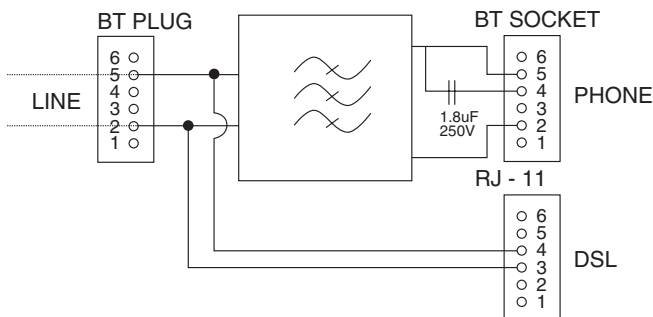

Z-350UK Block Schematic – includes a BT specified “Ringing Capacitor”

Z-BLOCKER® Z-350UK xDSL over POTS In-Line Filter

Z-BLOCKER® Z-350UK Filter Specifications

Matching impedance $Z_{\text{complex}(2)}$ of ITU-T G.992.1 E.1	230nF // 1050Ω + 320Ω
POTS Pass Band Return Loss terminated in ZHP	
0.3 – 0.5kHz	≥ 16 dB
0.5 – 2.0kHz	≥ 14 dB
2.0 – 3.4kHz	≥ 7.5 dB
Insertion Loss @ 1 kHz, 1 filter	< 1.0 dB
Insertion Loss Distortion; delta between 1 kHz and 200 Hz $\leq f \leq 4$ kHz levels	>1 dB
Isolation Resistance, branch-earth	>10 MΩ
Isolation Resistance, branch-branch	>1 MΩ
DC Resistance	< 50 Ω
Maximum peak signal power in 200-4000Hz	< 3 dBm
DC Feeding Current (Loop Current)	< 100 mA
AC ringing voltage (25-50Hz)	< 100 Vrms
Unbalance About Earth (terminated with 600Ω)	
15 Hz to 50 Hz	> 40 dB
50 Hz to 600 Hz	> 46 dB
600 Hz to 3400 Hz	> 52 dB
Metering Insertion Loss (12/16 kHz, < 5Vrms in 200Ω)	> 3 dB
Longitudinal Balance (25 kHz to 1.1 MHz)	
At Line/Phone Port with Phone/Line Port terminated in 100Ω	> 40 dB
VDSL Stop Band Return Loss (200 kHz to 1 MHz) with Line and VDSL ports	> 16 dB
Off-Hook VDSL Stop Band Isolation (Insertion Loss) w/ 100Ω at Line/Phone	
32 kHz to 200 KHz	> 29 dB
200 kHz to 30 MHz	> 55 dB
On-Hook VDSL Stop Band Isolation (Insertion Loss) w/ 100Ω at Line/Phone	
32 kHz to 350 KHz	> 29 dB
350 kHz to 30 MHz	> 55 dB
On-Hook VDSL Stop Band Isolation (Insertion Loss) w/ 100Ω at Line and 4kΩ //	
32 kHz to 350 KHz	> 18 dB
350 kHz to 30 MHz	> 55 dB
Common-Mode Insertion Loss (26 kHz to 30 MHz)	> 30 dB
Voice Band Noise at Phone Port	< -70 dBmp
Housing Dimensions (Length x Width x Height): 38mm x 43mm x 23mm (Cord	
Connectors: UK plug (Line); RJ11 Jack (DSL); UK socket (Phone)	

For More Information:

Americas - prodinfonetworkamericas@pulseelectronics.com | **Europe** - comms-Apps-Europe@pulseelectronics.com | **Asia** - prodinfonetworkapac@pulseelectronics.com

Performance warranty of products offered on this data sheet is limited to the parameters specified. Data is subject to change without notice. Other brand and product names mentioned herein may be trademarks or registered trademarks of their respective owners. © Copyright, 2019. Pulse Electronics, Inc. All rights reserved.